



Trans Industrial is committed to offering you quality products  
**ONE-STOP MOTION CONTROL SOLUTION EXPERT**  
 Specializing in R & D and production of various precision  
 planetary gear transmission products  
 Click <https://transreducer.com> for more information

**Planetary Gearbox**



Stepper/servo motor driving (for robot industry)

# Cycloidal pin-Wheel RV Reducer

High cost-effective/perfectly match and replace the sizes of Japanese harmonic reducers

**RV Reducer & Harmonic Gearbox**



**90 Degree Right Angle Gearbox**

**Planetary Gearbox**



**Headquarters**  
 Shanghai Trans Intelligent Technology Co., Ltd.  
 Add.: No.158, Kaile Road, Jinshang District, Shanghai, China  
 Tel: +86 131 6618 0210  
 Email: [info@mkdsh.com](mailto:info@mkdsh.com)  
 Web.: <https://mkdsh.com>

**Domestic Department**  
**Zhejiang Office**  
 Add. Room 516, Zhongqing Building, No. 68 Kangqiao Road,  
 Hangzhou, Zhejiang Province  
 Tel: +86-571-85278905 Fax: +86-571-85278905

**Tianjin Office**  
 Add.: No. 218, Building 6, hardware city, Nankai district,  
 Tianjin province  
 Tel: +862286709632

**International Department**  
 Sales Manager: Linda Zhang  
 Mob.: +86 1316618 0210 (whatsapp/skype/wechat)  
 Email: [gearbox@mkdsh.com](mailto:gearbox@mkdsh.com)

**Guangdong Office**  
 Add. No. 138 Zhen'an Road, Dongguan city, Guangdong province.  
 Tel: +86-755-23432659 Fax: +86-755-23432659

**Shandong Office**  
 Add.: Room 128, Lego international building, Huayuan east road,  
 Jinan city.  
 Tel.: +86-531-86956332 Fax.: +86-531-86956332



**Shanghai Trans Intelligent Technology Co., Ltd.**

# Company Profile

Shanghai Trans Intelligent Technology Co., Ltd.(Hereinafter referred to as TRANS) is a professional manufacturer in the field of motion control products, which integrates R & D, manufacturing and sales as a whole. The TRANS company's R&D team and factory colleagues have more than 20 years of gear design and manufacturing experience and have the core technology of this field and advanced processing equipment. In the early stage, the factory mainly produced worm gear reducers, UDL step-less speed changer, helical gear reducers, hypoid gear reducers, K, R, F, S series hard gear reducers, and PC helical gear reducers. The company is far-sighted and has laid out the company's future development direction in advance. In the mid-term, TRANS cooperated with the German reducer technical team to establish a precision gearbox division to cooperate in the development of high-level high-precision gear reducers, including planetary reducers and harmonic reducers (American genius inventor C W.Musser created and invented the principle of wave gear device), 90-degree right-angle servo gearbox (suitable for different installation and output requirements of automation), cycloidal pinwheel RV reducer (suitable for multi-joint robot industry). Also, the company produces related products in the motion control field such as precision rack and pinion, coupling, linear motor, servo motor, etc. Meanwhile, TRANS company also provide non-standard customized reducer services. The precision planetary reducer produced by the TRANS company has three characteristics of low backlash (3 ~ 8 arcmin), low noise (60dAB), and high efficiency (>=95%). The size and accuracy are fully matched with Japanese and German reducers, and can directly replace German and Japanese brand reducers. The products are suitable for servo motors and stepper motors produced by domestic and foreign servo factories, such as Panasonic, Yaskawa, Omron, Mitsubishi, Schneider, Delta, Siemens, MOOG, Beckoff, Festo, Leadshine, etc. Our company's precision reducers are widely used in laser cutting machines, woodworking engraving machines, gantry machine tools, industrial robots, 3C automation, plastic machinery, three-dimensional parking lots, photovoltaic equipment, automobile manufacturing, lithium batteries, milling machines, full servo tissue machinery, precision embossing Printing machines, servo pipe benders, precision coating machines, CNC spring machines, and other highly automated equipment.

The TRANS factory matches a large inventory of standard gearboxes and flanges suitable for different motor input sizes, which can achieve the fastest delivery time of 7~10 working days, saving customers costs in terms of time.

TRANS company's products have passed the ISO9001: 2015 quality management system, the European CE certification, and the US UL certification. The products have been sold to more than 100 countries at home and abroad, and have been widely recognized and repurchased by European and American customers who have high-quality requirements.

TRANS company is committed to the field of motion control, working with servo motor manufacturers and system integrators to serve the global automation industry and robotics, providing customers with high-quality products, timely and fast services, and striving to be a leader in the transmission field. Your satisfaction is our eternal pursuit.

## CONTENTS

PAGES

### RV-E Series



01-16

### RV-C Series



17-34

### RV-EM Series



35-43

### RV-CM CK, CW Series



44-66

### FHA Series



67-82

### FHD Series



83-90

# Product Application Industry

Palletizing robot / Rotary workh



Gantry loader / ATC device

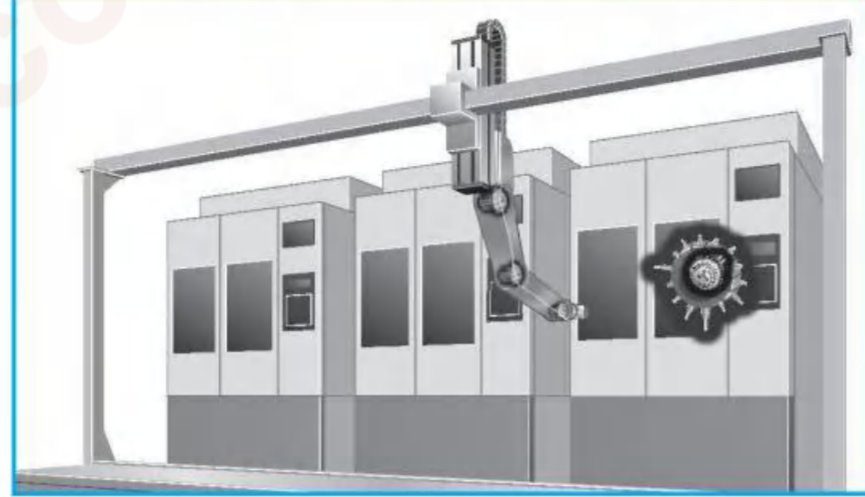

Machine tool ATC tool magazine

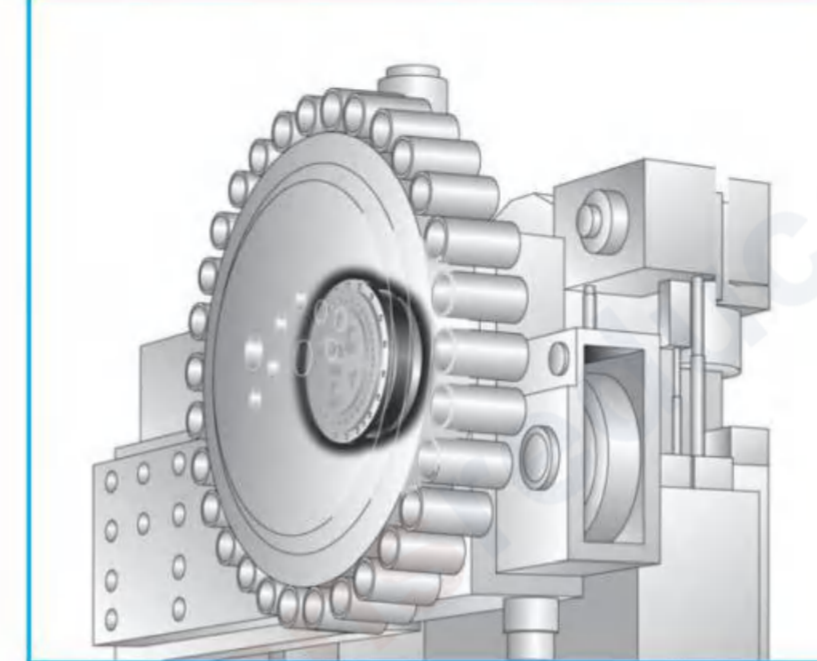

Machine tool (turret)

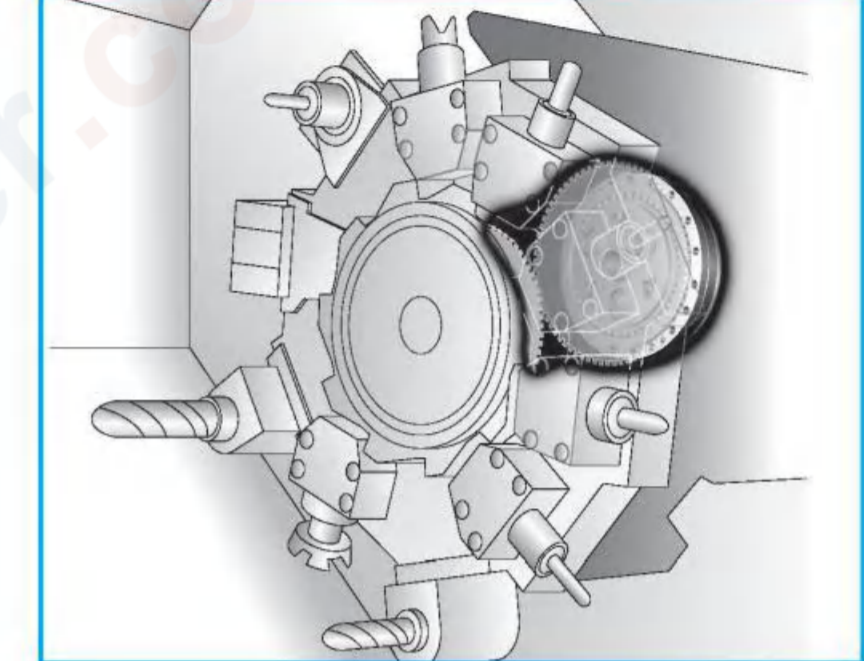

Various positioners



Horizontal multi-joint robot / Cylindrical coordinate robot

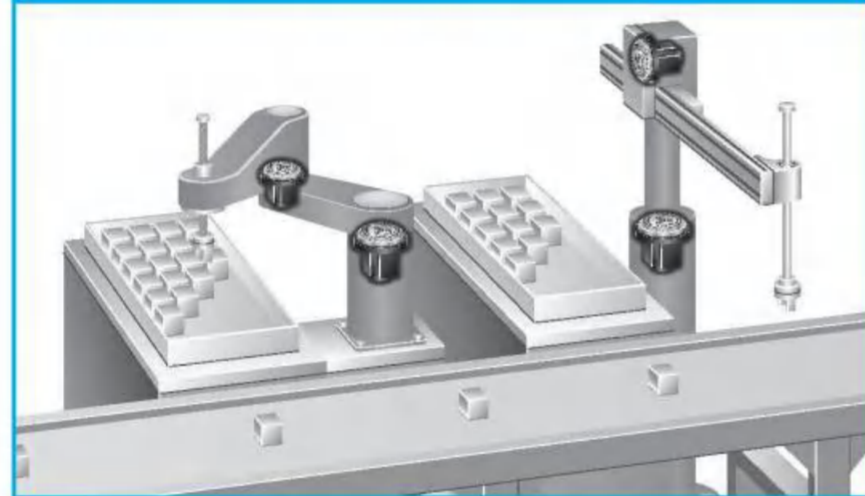

Positioning turntable (rotary axis)



Cover switch device

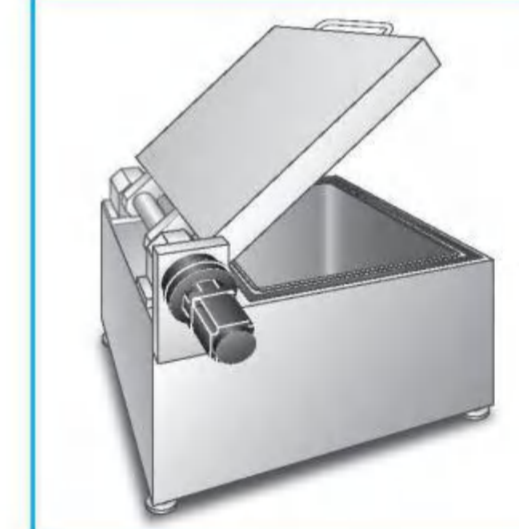

ABV drive



Vertical multi-joint robot (joint axis)



SCARA robot



Medical instruments

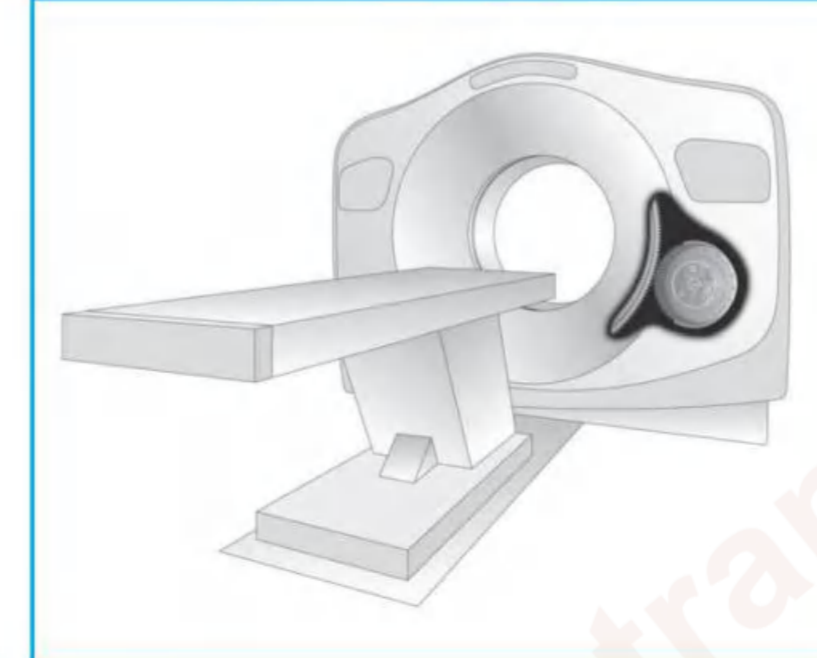

Glass substrate and wafer rotation axis

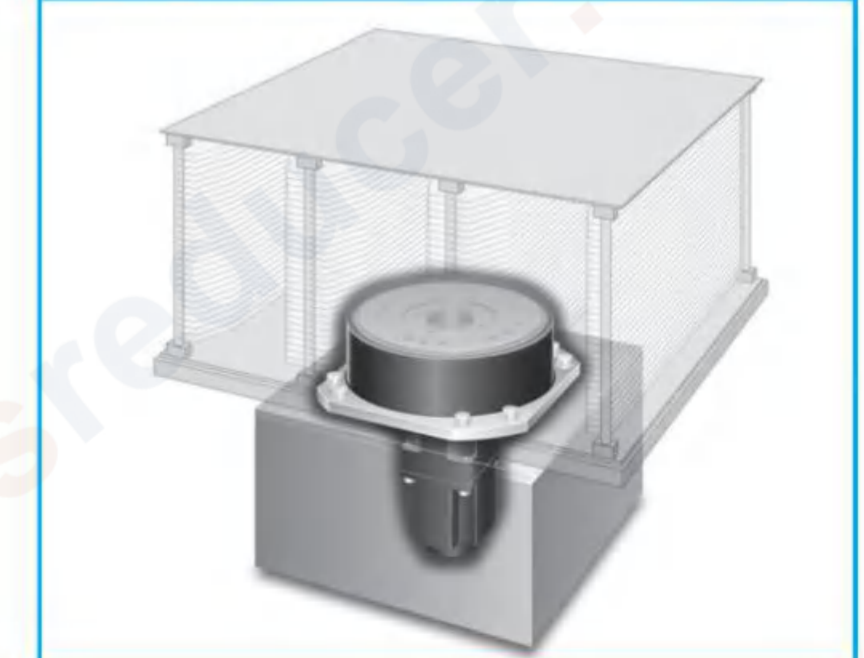

## RV-E series Features and construction

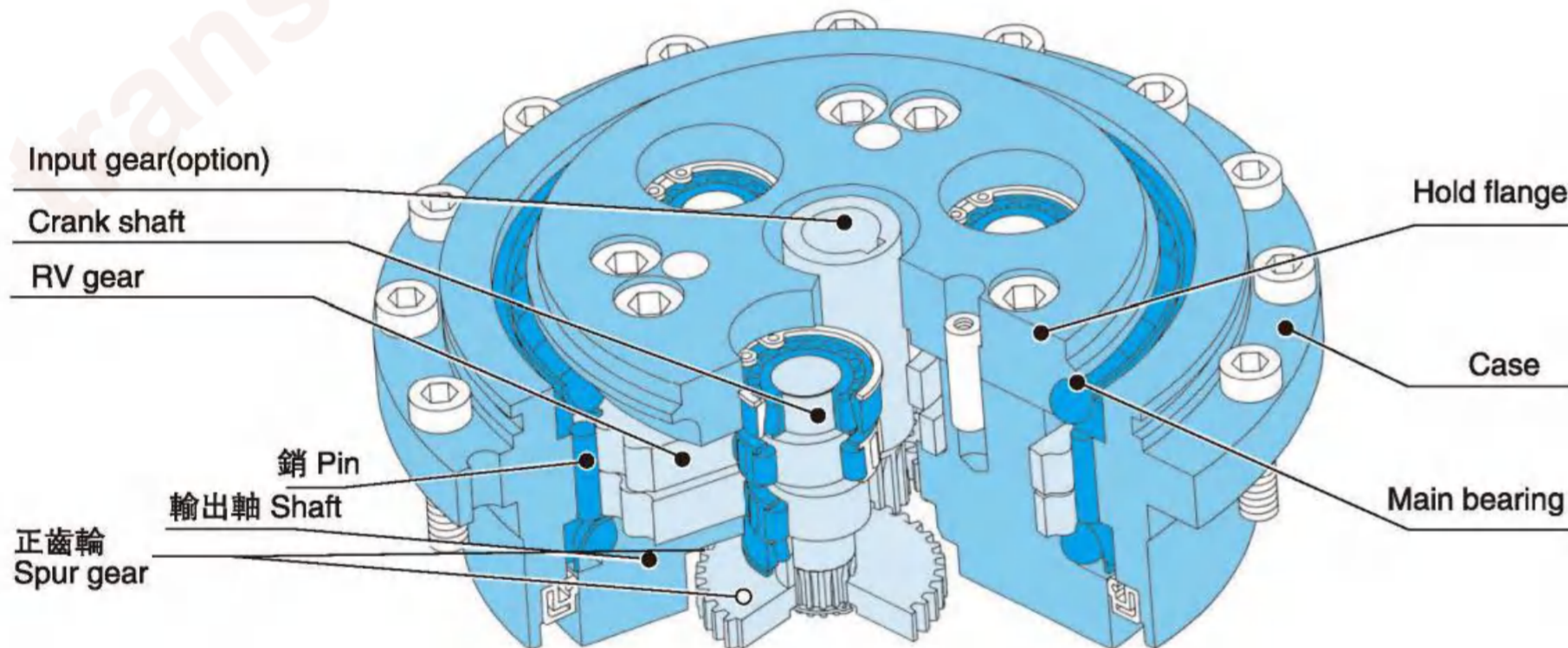

### Integrated angular ball bearings

#### Benefits:

- Increases reliability
- Reduces overall cost

#### Attributed to:

- Built-in angular ball bearing construction improves the ability to support external loads, increases moment rigidity and maximum allowable moment.
- Reduces the number of components required.
- Simplifies installation.

### 2-stage reduction

#### Benefits:

- Reduces vibration
- Reduces inertia ( $G\bar{J}$ )

#### Attributed to:

- Low speed rotation of the RV gear reduces vibration.
- Reduced size of the motor coupling part (input gear) lowers inertia.

### All main elements are supported on both sides

#### Benefits:

- Higher torsional stiffness
- Less vibration
- High shock load capability (5 times rated torque)

#### Detail:

- Crankshafts are supported on both sides of the reduction gear as shown below.

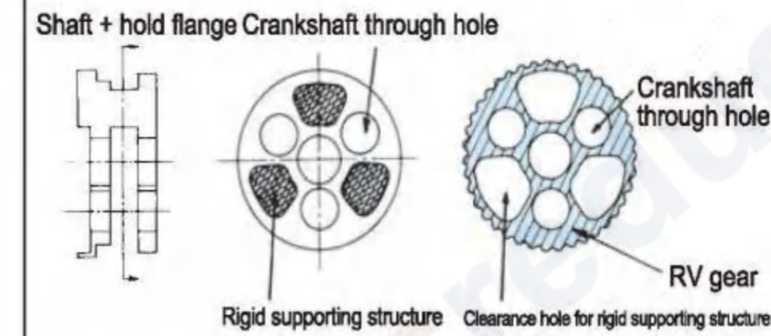

### Pin & gear structure

#### Benefits:

- Very low backlash (1 arc. min.)
- Higher shock load capability(5 times rated torque)

#### Attributed to:

- Synchroneshing of many RV gear teeth and pins.

### Rolling contact elements

#### Benefits:

- Excellent starting efficiency
- Low wear and longer life
- Low backlash (1 arc. min.)

#### Attributed to:

- Use of roller bearings throughout.

## RV-E Series

### Robot arm

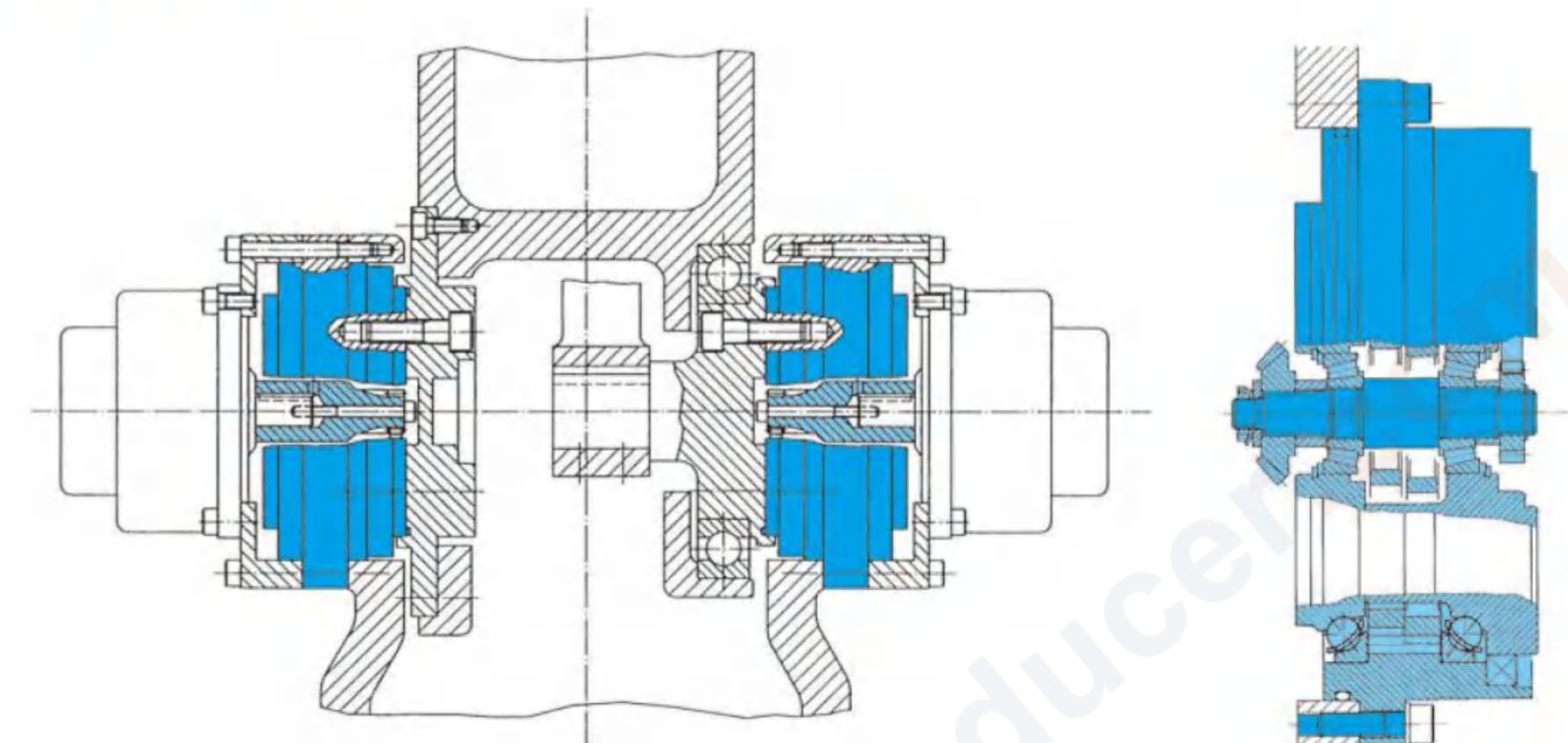

### Robot wrist axis

As shown in the figure(right), the input gear can also be supported within the reduction gear mechanism. Please contact FH for more details.

# RV-E series rotary direction and speed ratio

The rotary direction and speed ratio of the E series are shown below. Use the following figure to select a mechanism most suitable for your application.

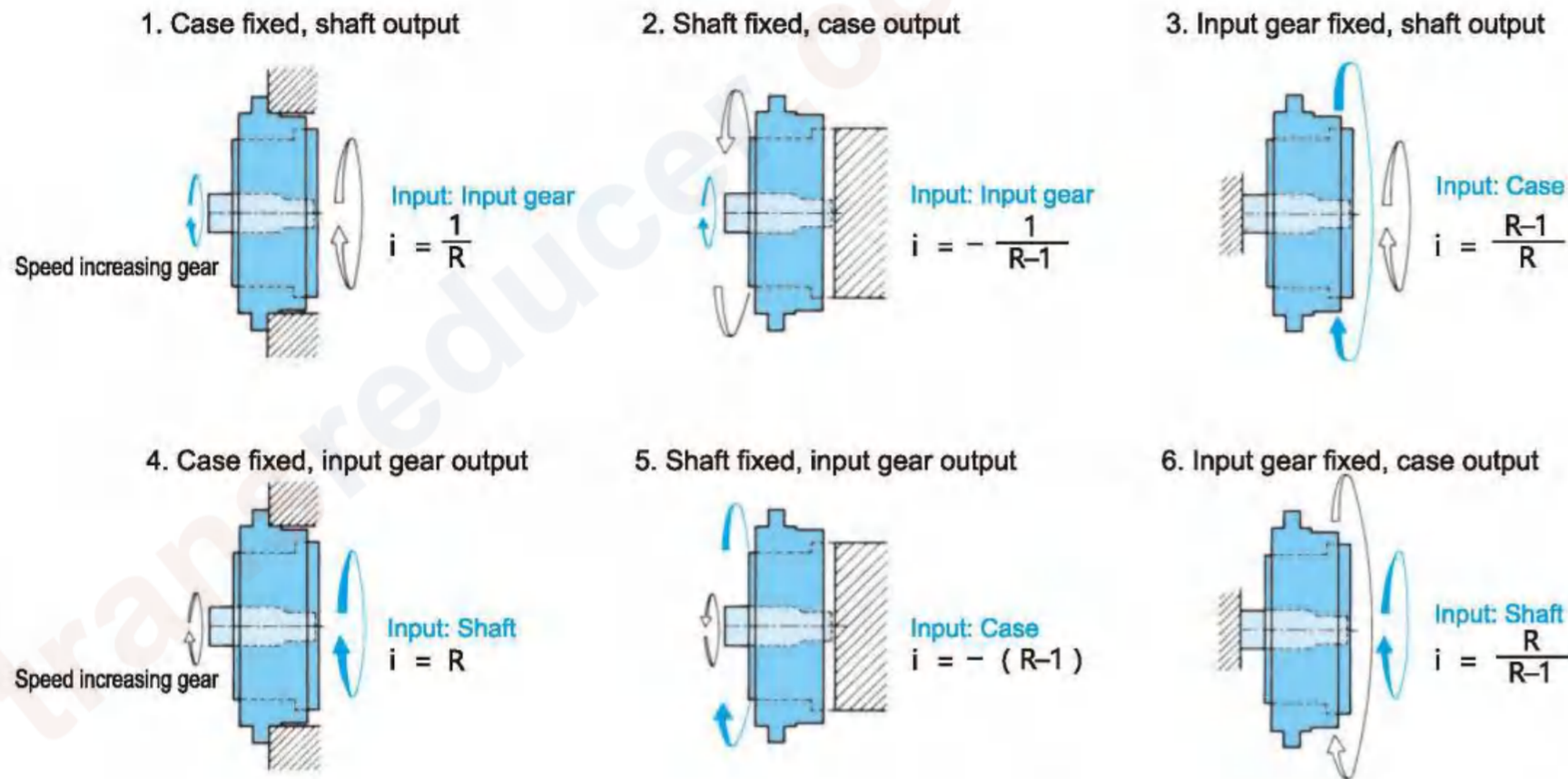

•The "i" in the above equations signifies the speed ratio of the output for the input in each case. The "+" signifies the output in the same direction as the input and the "-" signifies the output in the opposite direction to the input.  
 •The above figures show the situation when the motor is installed on the fixed side.

## RV-E ratio

The overall reduction ratio i (of the First and Second reduction stages) will differ depending on the use, and can be calculated using the speed ratio values displayed in the table below.

With the shaft as output;

$$R = 1 + \frac{Z_2}{Z_1} \cdot Z_4$$

R : Speed ratio  
 Z<sub>1</sub>: Number of teeth on input gear  
 Z<sub>2</sub>: Number of teeth on spur gear  
 Z<sub>3</sub>: Number of teeth on RV gear  
 Z<sub>4</sub>: Number of pins  
 i : Reduction ratio

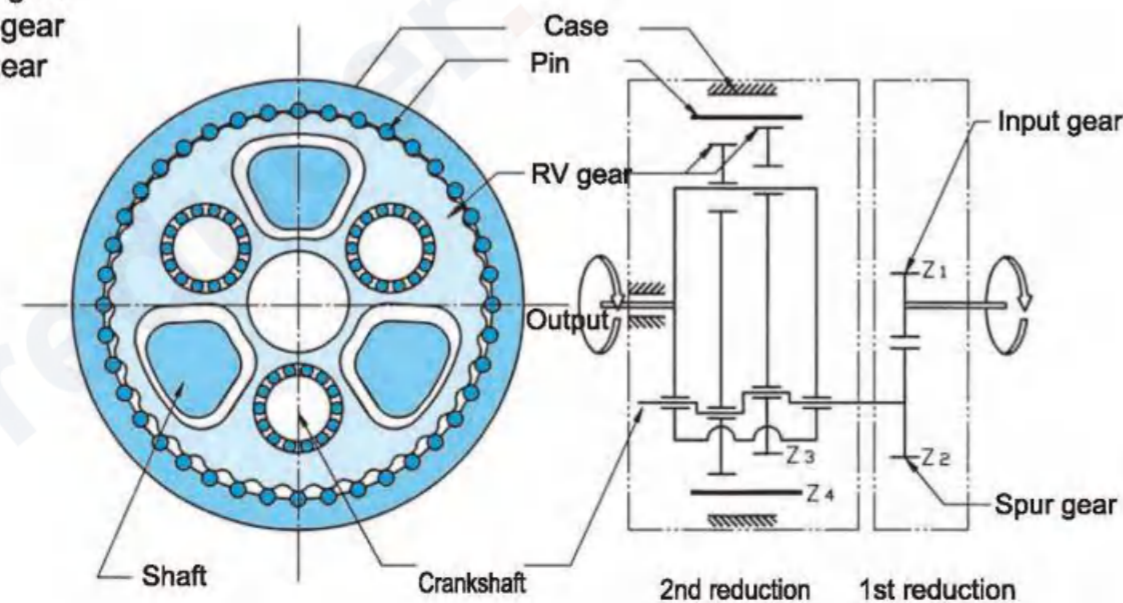

# RV-E Series Precision Robot Joints



## Principle of Speed Reduction

### 1st stage ...Spur gear reduction

- An input gear engages with and rotates spur gears that are coupled to crankshafts. Several overall gear ratios can be provided by selecting various first stage ratios.

### 2nd stage ...Epicyclic gear reduction

- Crankshafts driven by the spur gears cause an eccentric motion of two epicyclic gears called RV gears that are offset 180 degrees from one another to provide a balanced load.
- The eccentric motion of the RV gears causes engagement of the cycloidal shaped gear teeth with cylindrically shaped pins located around the inside edge of the case.
- In the course of one revolution of the crankshafts the teeth of the RV gear move the distance of one pin in the opposite direction of the rotating cranks. The motion of the RV gear is such that the teeth remain in close contact with the pins and multiple teeth share the load simultaneously.
- The output can be either the shaft or the case. If the case is fixed, the shaft is the output. If the shaft is fixed, the case is the output.

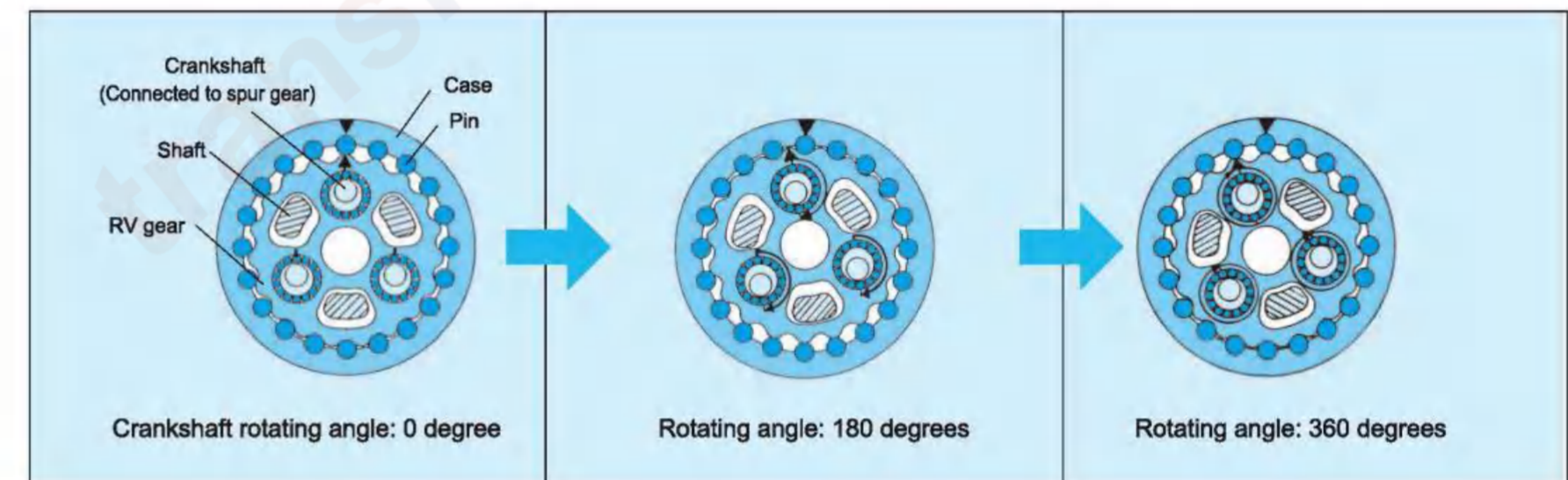

## RV-E series instruction

•When placing an order or making an inquiry, please use the following codes to specify the appropriate model.



Model code	Frame number	Series code	Ratio code	Input gear code Input spline code	Output shaft clamp code	Motor
RV	6	E: Main bearing built-in type	31, 43, 53.5, 59, 79, 103	A: Standard gear A B: Standard gear B Z: No gear	B: Bolt-clamping output shaft type P: Pin/bolt clamping output shaft type	Motor Model
	20		57, 81, 105, 121, 141, 161			
	40		57, 81, 105, 121, 153			
	80		57, 81, 101, 121, 153			
	110		81, 111, 161, 175			
	160		81, 101, 129, 145, 171			
	320		81, 101, 118.5, 129, 141, 171, 185			
	450		81, 101, 118.5, 129, 154.8, 171, 192.4			

# RV-E series Rating Table

Type	Ratio code	Output speed (rpm)		Output torque (Nm) / Input capacity (kW)										
		R Speed ratio		5	10	15	20	25	30	40	50	60		
		Shaft rotation	Case rotation											
RV-6E	31	31	30	101 / 0.07	81 / 0.11	72 / 0.15	66 / 0.19	62 / 0.22	58 / 0.25	54 / 0.30	50 / 0.35	47 / 0.40		
	43	43	42											
	53.5	53.5	52.5											
	59	59	58											
	79	79	78											
RV-20E	103	103	102											
	57	57	56	231 / 0.16	188 / 0.26	167 / 0.35	153 / 0.43	143 / 0.50	135 / 0.57	124 / 0.70	115 / 0.81	110 / 0.92		
	81	81	80											
	105	105	104											
	121	121	120											
141	141	140												
RV-40E	161	161	160											
	57	57	56	572 / 0.40	465 / 0.65	412 / 0.86	377 / 1.05	353 / 1.23	334 / 1.40	307 / 1.71	287 / 2.00	271 / 2.27		
	81	81	80											
	105	105	104											
	121	121	120											
153	153	152												
RV-80E	57	57	56											
	81	81	80	1,088 / 0.76	885 / 1.24	784 / 1.64	719 / 2.01	672 / 2.35	637 / 2.67	584 / 3.26	546 / 3.81	517 / 4.33		
	101	101	100											
	121	121	120											
	153	*1 (153)	*1 (152)											
175	175	174												
RV-110E	81	81	80											
	111	111	110	1,499 / 1.05	1,215 / 1.70	1,078 / 2.26	990 / 2.76	925 / 3.23	875 / 3.67	804 / 4.49				
	161	161	160											
	175	1227/7	1220/7											
	81	81	80											
101	101	100												
RV-160E	129	129	128	2,176 / 1.52	1,774 / 2.48	1,568 / 3.28	1,441 / 4.02	1,343 / 4.69	1,274 / 5.34					
	145	145	144											
	171	171	170											
	81	81	80											
	101	101	100											
RV-320E	118.5	118.5	117.5	4,361 / 3.04	3,538 / 4.94	3,136 / 6.57	2,881 / 8.05	2,695 / 9.41	2,548 / 10.7					
	129	129	128											
	141	141	140											
	171	171	170											
	185	185	184											
RV-450E	81	81	80											
	101	101	100	6,135 / 4.28	4,978 / 6.95	4,410 / 9.24	4,047 / 11.3	3,783 / 13.2						
	118.5	118.5	117.5											
	129	129	128											
	154.8	2013/13	2000/13											
171	171	170												
192	1347/7	1340/7												

Note: 1. The allowable output speed will differ depending upon the duty ratio, load, and ambient temperature. Contact us regarding use above the allowable output speed N<sub>s1</sub>.

2. The input capacity (kW) is calculated according to the following calculation formula:

$$\text{Input capacity (kW)} = \frac{2\pi \cdot N \cdot T}{60 \cdot \eta \cdot 10^3}$$

N: Output speed (rpm)  
T: Output torque (Nm)  
η = 75: Reduction gear efficiency (%)

Note: The input capacity is a reference value.

3. When the reduction gear is used at low temperatures, there will be a larger no-load running torque. Note this characteristic when selecting a motor. (Refer to "Low temperature characteristic" on page 93)

T <sub>2</sub> Rated torque (Note 7)	N <sub>2</sub> Rated output Speed	K Rated service life	T <sub>s1</sub> Allowable acceleration deceleration torque	T <sub>s2</sub> Momentary maximum allowable torque	N <sub>2a</sub> Maximum allowable output speed (Note 1)	Backlash	MAX. Lost motion MAX.	MAX. Angular transmission error MAX.	Startup efficiency (Typical value)	M <sub>01</sub> Allowable moment (Note 4)	M <sub>02</sub> Momentary allowable moment (Max.)	W <sub>r</sub> Allowable radial load (Note 10)	I Reduced value of the inertia moment for the input shaft (Note 5)	Weight
(Nm)	(rpm)	(h)	(Nm)	(Nm)	(r/min)	(arc.sec)	(arc.min)	(arc.sec)	(%)	(Nm)	(Nm)	(N)	(kgm <sup>2</sup> )	(kg)
58	30	6,000	117	294	100	1.5	1.5	80	70	196	392	2,140	2.63×10 <sup>-6</sup> 2.00×10 <sup>-6</sup> 1.53×10 <sup>-6</sup> 1.39×10 <sup>-6</sup> 1.09×10 <sup>-6</sup> 0.74×10 <sup>-6</sup>	2.5
167	15	6,000	412	833	75	1.0	1.0	70	75	882	1,764	7,785	9.66×10 <sup>-6</sup> 6.07×10 <sup>-6</sup> 4.32×10 <sup>-6</sup> 3.56×10 <sup>-6</sup> 2.88×10 <sup>-6</sup> 2.39×10 <sup>-6</sup>	4.7
412	15	6,000	1,029	2,058	70	1.0	1.0	60	85	1,666	3,332	11,594	3.25×10 <sup>-5</sup> 2.20×10 <sup>-5</sup> 1.63×10 <sup>-5</sup> 1.37×10 <sup>-5</sup> 1.01×10 <sup>-5</sup>	9.3
784	15	6,000	1,960	Bolt joint 3,920 Pin/bolt joint 3,185	70	1.0	1.0	50	85	Bolt joint 2,156 Pin/bolt joint 1,735	Bolt joint 4,312 Pin/bolt joint 2,156	Bolt joint 12,988 Pin/bolt joint 10,452	8.16×10 <sup>-5</sup> 6.00×10 <sup>-5</sup> 4.82×10 <sup>-5</sup> 3.96×10 <sup>-5</sup> 2.98×10 <sup>-5</sup>	Bolt joint 13.1 Pin/bolt joint 12.7
1,078	15	6,000	2,695	5,390	50	1.0	1.0	50	85	2,940	5,880	16,648	9.88×10 <sup>-5</sup> 6.96×10 <sup>-5</sup> 4.36×10 <sup>-5</sup> 3.89×10 <sup>-5</sup>	17.4
1,568	15	6,000	3,920	Bolt joint 7,840 Pin/bolt joint 6,615	45	1.0	1.0	50	85	3,920	Bolt joint 7,840 Pin/bolt joint 6,762	18,587	1.77×10 <sup>-4</sup> 1.40×10 <sup>-4</sup> 1.06×10 <sup>-4</sup> 0.87×10 <sup>-4</sup> 0.74×10 <sup>-4</sup>	26.4
3,136	15	6,000	7,840	Bolt joint 15,680 Pin/bolt joint 12,250	35	1.0	1.0	50	80	Bolt joint 7,056 Pin/bolt joint 6,174	Bolt joint 14,112 Pin/bolt joint 10,976	Bolt joint 28,067 Pin/bolt joint 24,558	4.83×10 <sup>-4</sup> 3.79×10 <sup>-4</sup> 3.15×10 <sup>-4</sup> 2.84×10 <sup>-4</sup> 2.54×10 <sup>-4</sup> 1.97×10 <sup>-4</sup> 1.77×10 <sup>-4</sup>	44.3
4,410	15	6,000	11,025	Bolt joint 22,050 Pin/bolt joint 18,620	25	1.0	1.0	50	85	8,820	Bolt joint 17,640 Pin/bolt joint 13,524	30,133	8.75×10 <sup>-4</sup> 6.91×10 <sup>-4</sup> 5.75×10 <sup>-4</sup> 5.20×10 <sup>-4</sup> 4.12×10 <sup>-4</sup> 3.61×10 <sup>-4</sup> 3.07×10 <sup>-4</sup>	66.4

Note:

- The allowable moment will differ depending on the thrust load. Check the allowable moment diagram (p. 91).
- The inertia moment value is for the reduction gear. It does not include the inertia moment for the input gear.
- For the moment rigidity and torsional rigidity, refer to the calculation of tilt angle and the torsion angle (p. 99).
- The rated torque is the value that produces the rated service life based on operation at the rated output speed; it does not indicate the maximum load. Refer to the "Glossary" (p.81) and the "Product selection flowchart" (p.82).
- Contact us regarding speed ratios other than those listed above.
- The specifications above are based on Nabtesco evaluation methods; this product should only be used after confirming that it is appropriate for the operating conditions of your system.
- When radial load is applied within dimension b, use the reduction gear within the allowable radial load.
- \*1 The R=153 for the RV-80E is only for the bolt-clamping output shaft type (page 20, 21).

## RV-6E Bolt clamping output shaft type

Ratio Type RV-6E-□-A-B

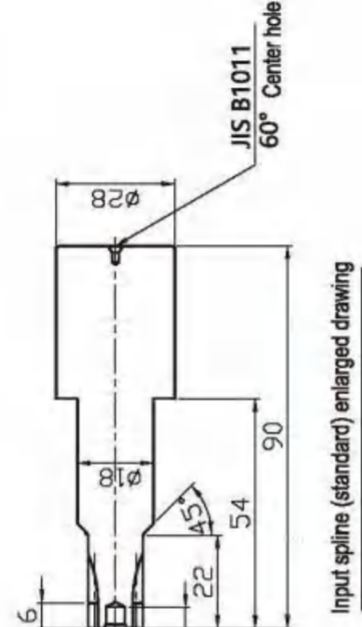
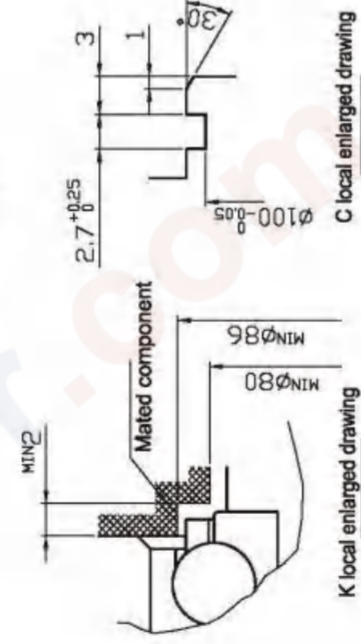
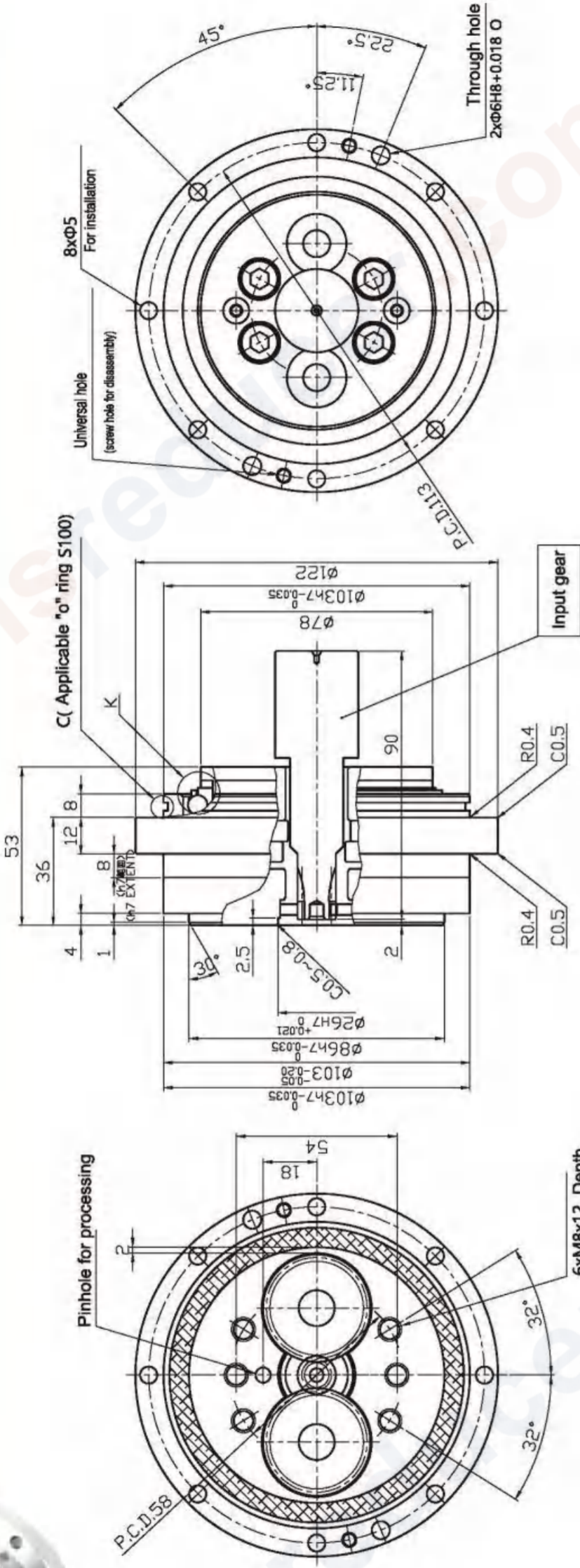

### Allowable transmission torque

	Screw bolt	Taper pin	Amount
Shell side	627.2Nm		627.2Nm
Shaft side	607.6Nm		607.6Nm

Note: 1) "C" type ring and screw bolt, washer for installation are to be provided by customer.  
2) Please forgive not to inform in advance for the anytime changes of specifications, sizes.

Specifications and sizes might be changed without any advanced announcement



## RV-20E Bolt clamping output shaft type

Ratio Type RV-20E-□-A-B

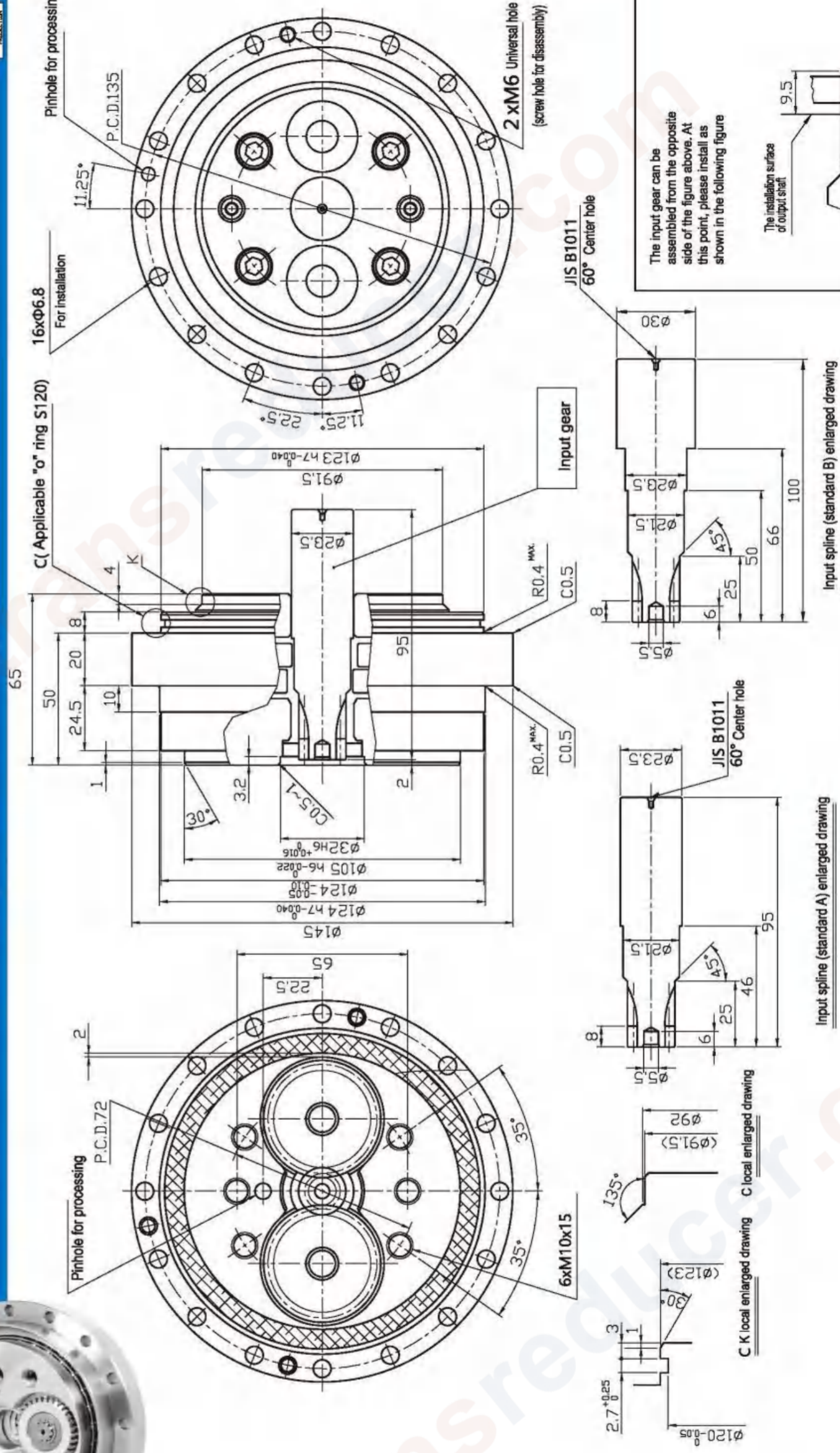

### Allowable transmission torque

	Screw bolt	Taper pin	Amount
Shell side	2136.4Nm		2136.4Nm
Shaft side	1195.6Nm		1195.6Nm

Note: 1) "C" type ring and screw bolt, washer for installation are to be provided by customer.  
2) Please forgive not to inform in advance for the anytime changes of specifications, sizes.

Specifications and sizes might be changed without any advanced announcement

**Bolt clamping output shaft type**      **Type**      **RV-40E-□-□-A-B**      **Ratio**      **A-B**

**Input gear**

16xØ9 For installation

2 xM8 Universal hole (screw hole for disassembly)

11.25° 22.5° P.C.D.175

C(Applicable "o" ring AS(ARP)568-258)

76 68 31 24 10 7 1 1.0 0.7 EXTEND 1.50 1.00 3 3.8 1 30 30 R1MAX C0.5

Input gear

JIS B1011 60° Center hole

10 10 7 29 53 76 115 10 10 7 29 53 76 115

Input spline (standard A) enlarged drawing (S=1.5/1)

Input spline (standard B) enlarged drawing (S=1.5/1)

JIS B1011 60° Center hole

10 10 7 29 53 100

C local enlarged drawing

4.78<sup>+0.25</sup> 4 1 30 (Ø160) 153.83<sup>+0.05</sup>

Pinhole for processing P.C.D.98 2 85 30.5 35° 6xM14x18 Depth

Allowable transmission torque

	Screw bolt	Taper pin	Amount
Shell side	5027.4Nm		5027.4Nm
Shaft side	3204.6Nm		3204.6Nm

Note: 1) "O" type ring and screw bolt, washer for installation are to be provided by customer.  
2) Please forgive not to inform in advance for the anytime changes of specifications, sizes.

Specifications and sizes might be changed without any advanced announcement

**Bolt clamping output shaft type**      **Type**      **RV-80E-□-□-A-B**      **Ratio**      **A-B**

**Input gear**

16xØ9 For installation

2 xM8 Universal hole (screw hole for disassembly)

11.25° 22.5° P.C.D.206

C(Applicable "o" ring AS(ARP)568-263)

84 75 48 15 11 10 1 1.0 0.7 EXTEND 1.50 1.00 3 3.8 1 30 30 R1MAX C0.5~1

Input gear

JIS B1011 60° Center hole

10 10 7 29 53 76 130 10 10 7 29 53 76 130

Input spline (standard A) enlarged drawing (S=1.5/1)

Input spline (standard B) enlarged drawing (S=1.5/1)

JIS B1011 60° Center hole

10 10 7 29 53 100

C local enlarged drawing

4.8<sup>+0.1</sup> 4 1 30 (Ø190) 184<sup>+0.05</sup>

Pinhole for processing P.C.D.142 10° 10° 12° 9° 12° 42 6xM10x15 Depth 12xM8x13 Depth

Allowable transmission torque

	Screw bolt	Taper pin	Amount
Shell side	5919.2Nm		5919.2Nm
Shaft side	4939.2Nm		4939.2Nm

Note: 1) "O" type ring and screw bolt, washer for installation are to be provided by customer.  
2) Please forgive not to inform in advance for the anytime changes of specifications, sizes.

Specifications and sizes might be changed without any advanced announcement





## RV-110E Bolt clamping output shaft type

Ratio

## Type RV-110E-□-A-B



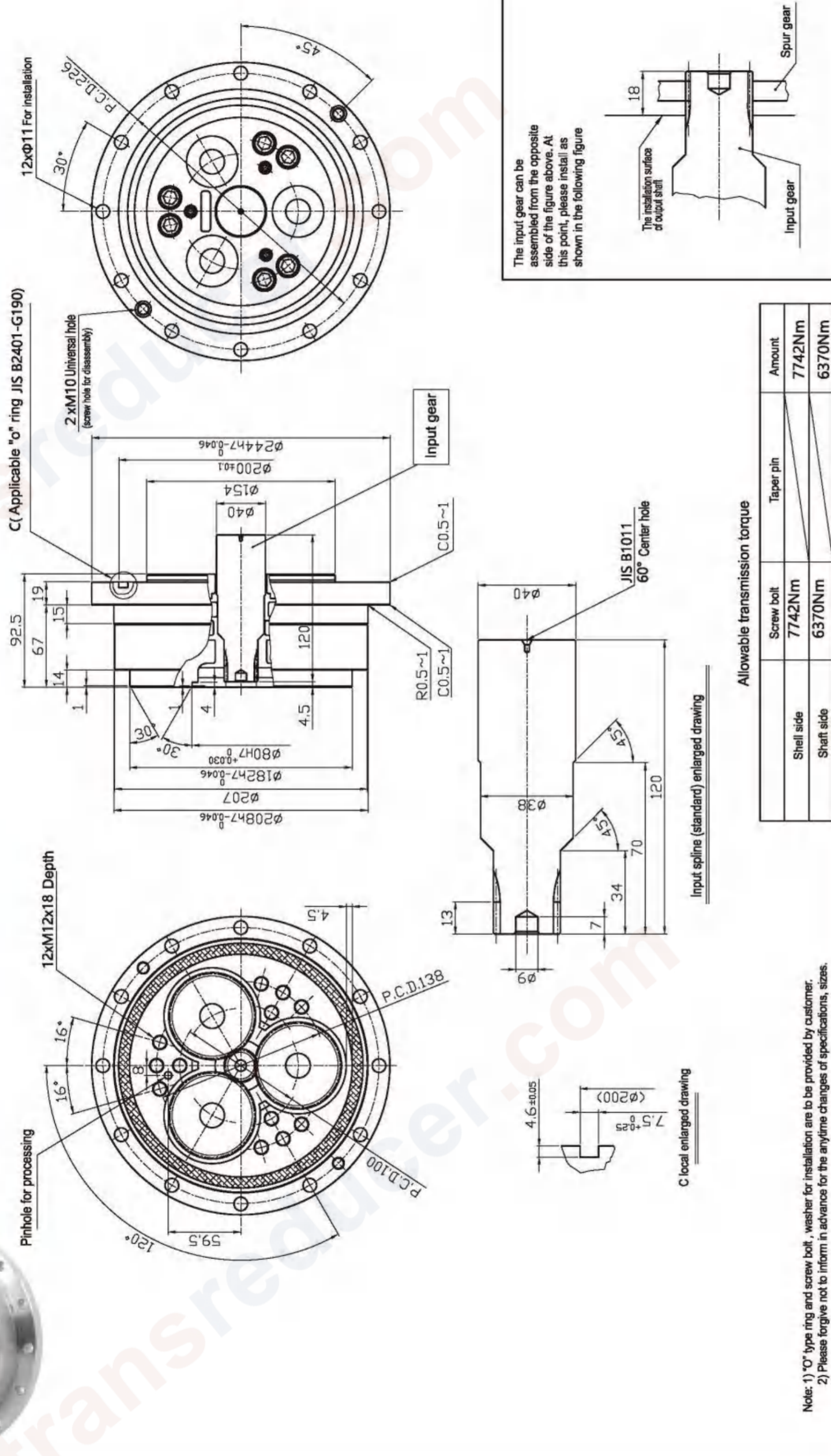

Note: 1) "O" type ring and screw bolt, washer for installation are to be provided by customer.  
2) Please forgive not to inform in advance for the anytime changes of specifications, sizes.

Specifications and sizes might be changed without any advanced announcement.

Specifications and sizes might be changed without any advanced announcement.

Note: 1) "O" type ring and screw bolt, washer for installation are to be provided by customer.  
2) Please forgive not to inform in advance for the anytime changes of specifications, sizes.

Allowable transmission torque

	Screw bolt	Taper pin	Amount
Shell side	7742Nm		7742Nm
Shaft side	6370Nm		6370Nm

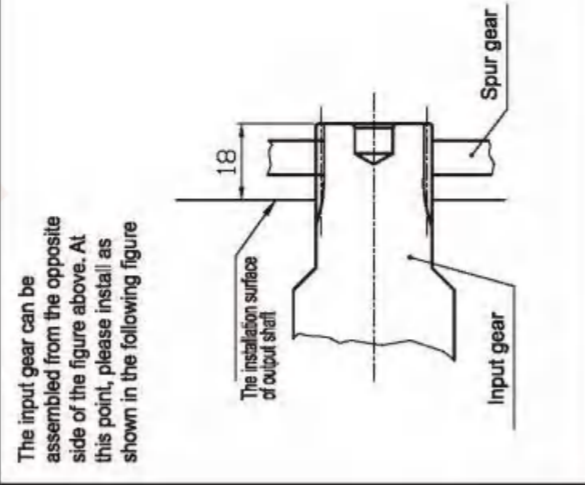



## RV-160E Bolt clamping output shaft type

Ratio

## Type RV-160E-□-A-B

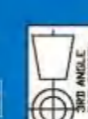

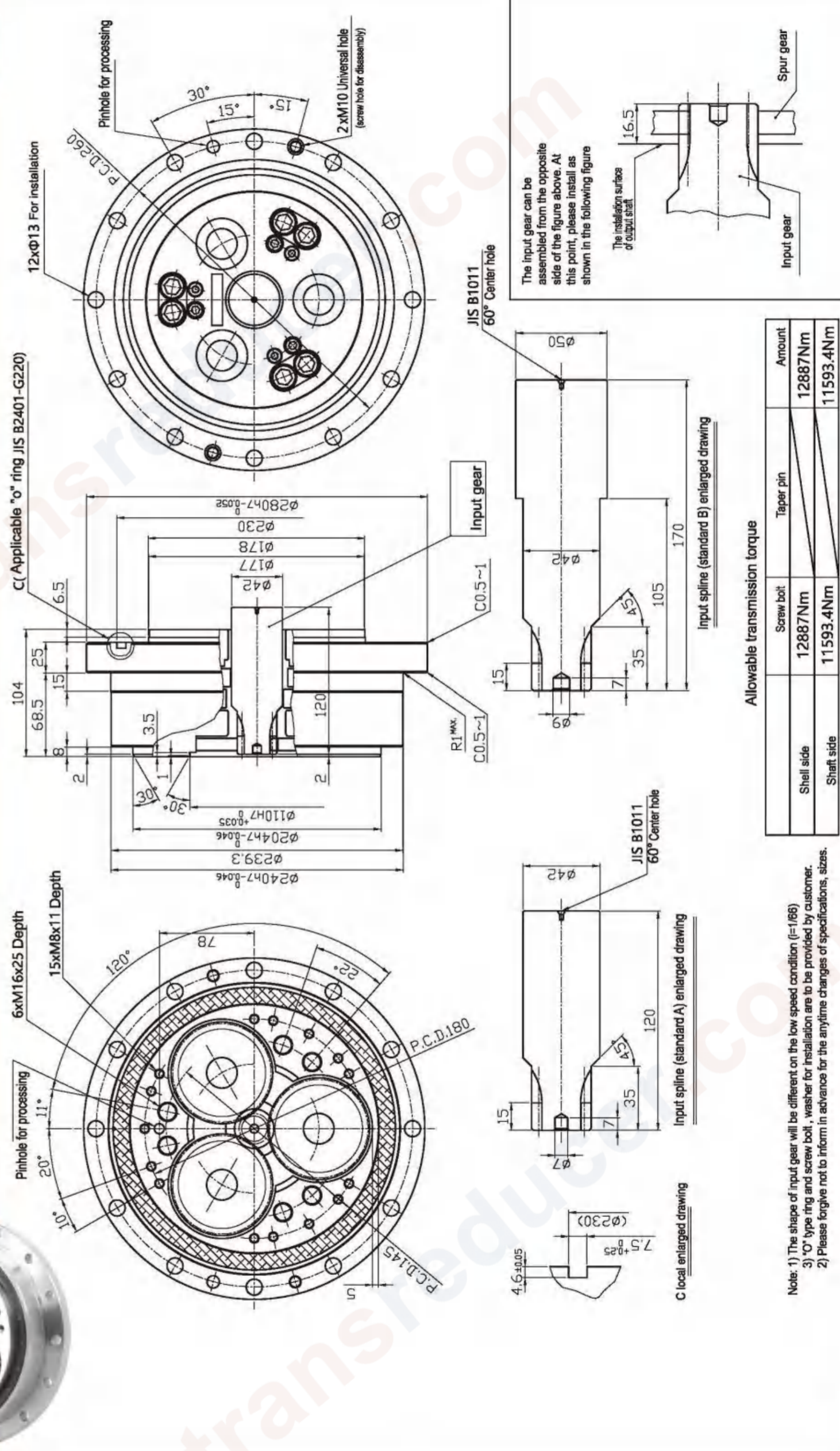

Note: 1) The shape of input gear will be different on the low speed condition (i=1/66)  
3) "O" type ring and screw bolt, washer for installation are to be provided by customer.  
2) Please forgive not to inform in advance for the anytime changes of specifications, sizes.

Specifications and sizes might be changed without any advanced announcement.

Allowable transmission torque

	Screw bolt	Taper pin	Amount
Shell side	12887Nm		12887Nm
Shaft side	11593.4Nm		11593.4Nm

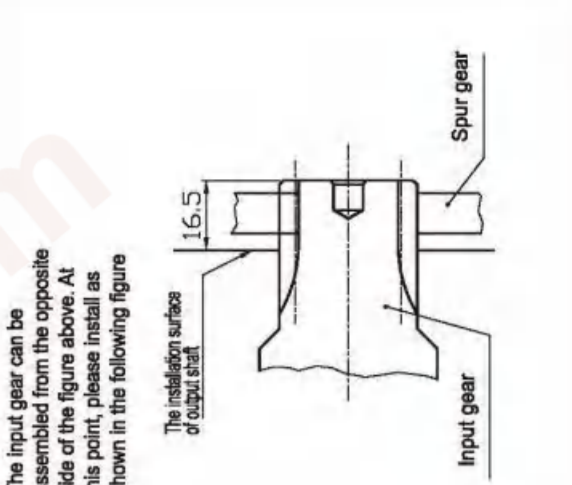

Specifications and sizes might be changed without any advanced announcement.

Note: 1) The shape of input gear will be different on the low speed condition (i=1/66)  
3) "O" type ring and screw bolt, washer for installation are to be provided by customer.  
2) Please forgive not to inform in advance for the anytime changes of specifications, sizes.



# RV-E Series Design Points Installation Components

## Design of the motor mounting flange

In order to avoid contact with gearbox components, refer to the sizes indicated in the "External Dimensions" drawings when designing the motor mounting flange.

Note: The size and number of bolts for the motor mounting flange should be determined with the torque and moment taken into consideration, and should be positioned in line with the gearbox's case mounting holes.

After installing the gearbox, we recommend installing an adding and draining grease fitting to enable grease replacement. An installation example is shown below.

Use the specified tightening torque to uniformly tighten the hexagon socket head cap screws (with corresponding conical spring washers)

To obtain maximum performance from the E series, it is important to optimally design the assembly, installation, lubrication, and sealing.

Be sure to read the following precautions before designing. As angular ball bearings are used as the main bearings, designing the mating component dimensions according to the table on the right to make sure that the bearing retainer does not come in contact with the motor mounting flange.

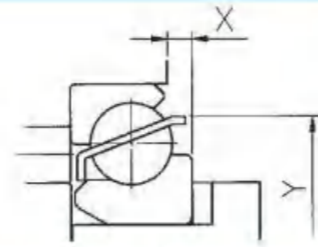

	X	Y
RV-6E	MAX1.9	MAXφ 85
RV-320E	MAX3.2	MAXφ222.2
RV-450E	MAX5.5	MAXφ285

With other models, the retainer does not stick out from the casing, so no special attention is needed.

## RV-E Series Assembly accuracy

Design the motor mounting flange according to the following accuracy. Poor assembly accuracy easily causes vibration and noise.

(Unit : mm)

Model	Concentricity tolerance		
	a	a	
RV-6E	MAX0.03	RV-110E	MAX0.03
RV-20E	MAX0.03	RV-160E	MAX0.05
RV-40E	MAX0.03	RV-320E	MAX0.05
RV-80E	MAX0.03	RV-450E	MAX0.05

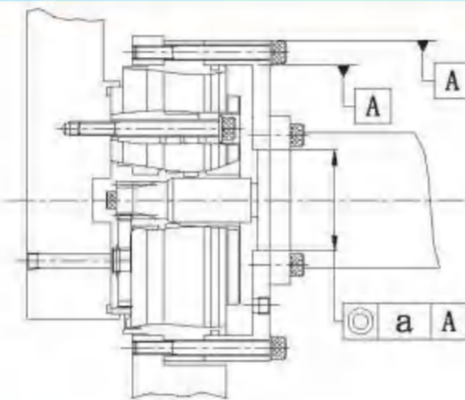

## RV-E Series Installation procedure

- Typical installation examples for gearboxes to be mounted on the mating components are shown below. Be sure to apply the specified amount of the specified grease during assembly.

Refer to the O-ring seals shown to make a seal design for the mounting side.

If O-ring (II) cannot be used due to the structure, apply the appropriate liquid sealant from the table on the right.

If a seal cannot be formed by applying liquid sealants due to the structure, use O-ring (I) and (III) on page 22.

- Bolt clamping output shaft type

Note: The sizes of bolts for tightening the output shaft are not all the same. Make sure that each bolt is tightened with the specified torque after assembling.

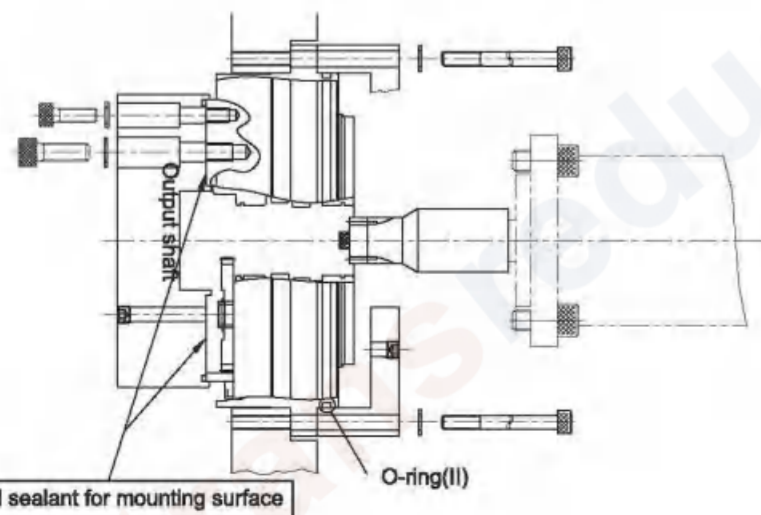

### Recommended liquid sealant

Manufacturer	Characteristics and applications
Three Bond 1211 (Three Bond)	<ul style="list-style-type: none"> <li>Silicone-based, solventless type</li> <li>Semi-dry gasket</li> </ul>
HERME SERL SS-60F (Nihon-Hermetics)	<ul style="list-style-type: none"> <li>One-part, non-solvent elastic sealant</li> <li>Metal contact side (flange surface) seal</li> <li>Three Bond1211</li> <li>Any product basically equivalent to ThreeBond 1211</li> </ul>
Loctite515 (Henkel)	<ul style="list-style-type: none"> <li>Anaerobic flange sealant</li> <li>Metal contact side (flange surface) seal</li> </ul>

Notes 1. Do not use these sealants for copper material or copper alloy material.  
2. If these sealants need to be used under special conditions such as concentrated alkali, pressurized steam, etc., please contact us.

### O-ring(II)

	Applicable O-ring
RV-6E	S100
RV-20E	S120
RV-40E	AS568-258
RV-80E	AS568-263
RV-110E	G190
RV-160E	G220
RV-320E	G270
RV-450E	G300

- Pin/bolt clamping output shaft type

Note: The prepared pinhole and the output shaft need to be reamed jointly with a reamer before knocking in the taper pin. The gearbox needs to be appropriately masked during reaming to prevent chips from entering inside.

### RV-20E, 40E Installation example

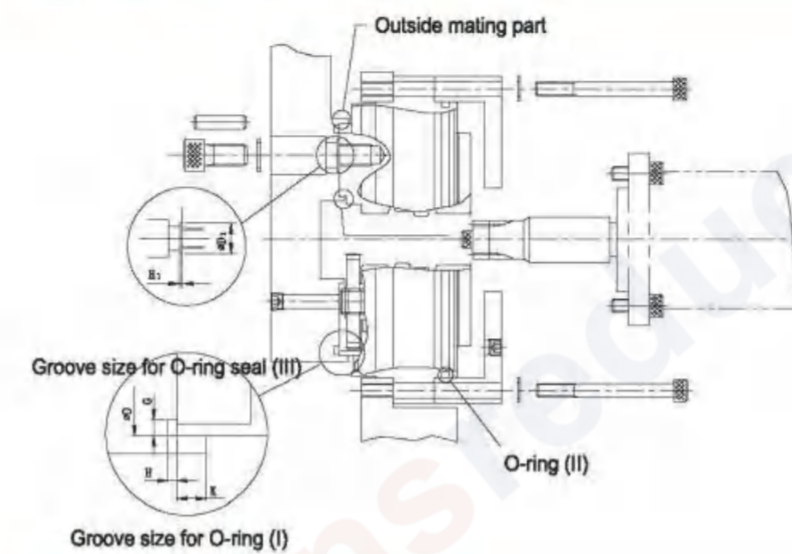

### RV-160E, 320E, 450E Installation example

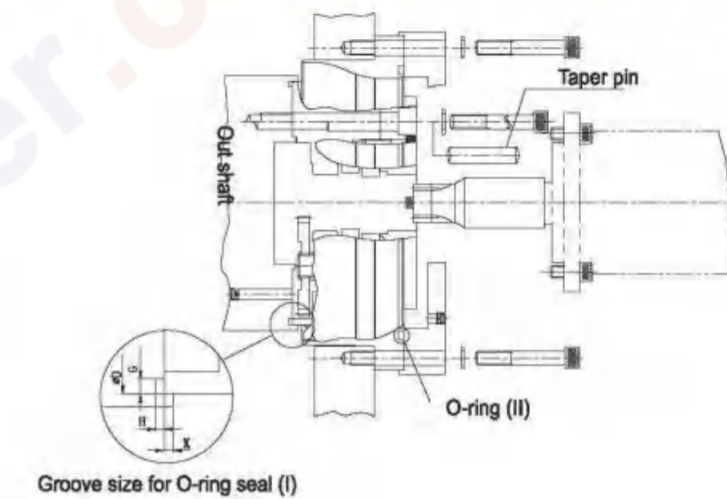

### RV-80E Installation example

A different method is used on RV-80E to knock in the taper pin, so follow the next procedure for assembling.

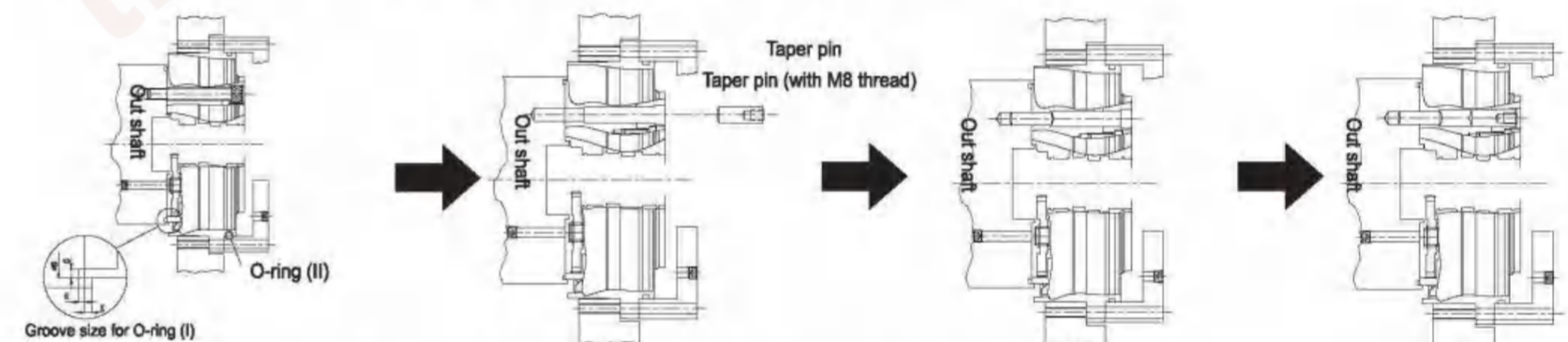

- Loosely tighten the hexagon socket head cap screw to temporarily secure the gearbox shaft to the output shaft.
- Remove the taper pin (with M8 screw) installed in the gearbox.
- From the hole of the removed taper pin, drill a hole for the taper pin (10 mm. dia.) in the output shaft. (At this time, masking is needed to prevent chips from entering the gearbox.)
- After reaming, remove the bolt to remove the gearbox, then remove any chips and burrs.
- Install the gearbox and knock in the taper pin for fixing the output shaft.
- Tighten the hexagon socket head cap screw securely to fix the gearbox to the output shaft.
- Be sure to knock in the taper pin (with M8 screw) embedded in the gearbox. Use a taper pin with screw.

### Dimensions for O-ring (I) seal

(Unit : mm)

	RV-20E (A)	RV-20E (B)	RV-40E	RV-80E	RV-110E	RV-160E	RV-320E	RV-450E
O-ring Dimensions	ID No.	AS568-045	S100	S132	AS568-163	AS568-167	AS568-265	AS568-275
	Wire dia.	φ1.78 ±0.07	φ2.0 ±0.1	φ2.0 ±0.1	φ2.62 ±0.07	φ2.62 ±0.07	φ3.53 ±0.1	φ3.53 ±0.1
Groove dimensions	I. D.	φ101.32 ±0.38	φ99.5 ±0.4	φ131.5 ±0.6	φ152.07 ±0.58	φ177.47 ±0.58	φ196.44 ±0.76	φ266.29 ±0.76
	Outside dia. D	φ105	φ105	φ135	φ160	φ182	φ204	φ273
	Depth H	1.27 ±0.05	1.5 <sup>-0.1</sup>	1.5 <sup>-0.1</sup>	2.06 ±0.05	2.06 ±0.05	2.82 ±0.05	2.82 ±0.05
	Width G	2.39 <sup>+0.25</sup>	2.7 <sup>+0.25</sup>	2.7 <sup>+0.25</sup>	3.58 <sup>+0.25</sup>	3.58 <sup>+0.25</sup>	4.78 <sup>+0.25</sup>	4.78 <sup>+0.25</sup>
Height (for reference) K	3	3	3	3	3	4	4	

### Dimensions for O-ring (II) seal

(Unit : mm)

	RV-20E	RV-40E	RV-80E	RV-160E	RV-320E	RV-450E
ID No.	S120	AS568-258	AS568-263	G220	G270	G300

### Dimensions for O-ring (III) seal

(Unit : mm)

	RV-20E	RV-40E	
O-ring Dimensions	ID No.	S12.5	S14
	Wire dia.	φ1.5 ±0.1	φ1.5 ±0.1
	I. D.	φ12	φ13.5
	Outside dia. D <sub>1</sub>	φ14.8 ±0.1	φ16.3 ±0.1
Depth H <sub>1</sub>	1.8 <sub>1</sub>	1.8 <sub>1</sub>	

Notes 1. Use O-ring seal of either type (A) or type (B).  
2. The S type ID number is the manufacturer's own standard.

## RV-C series Features and construction

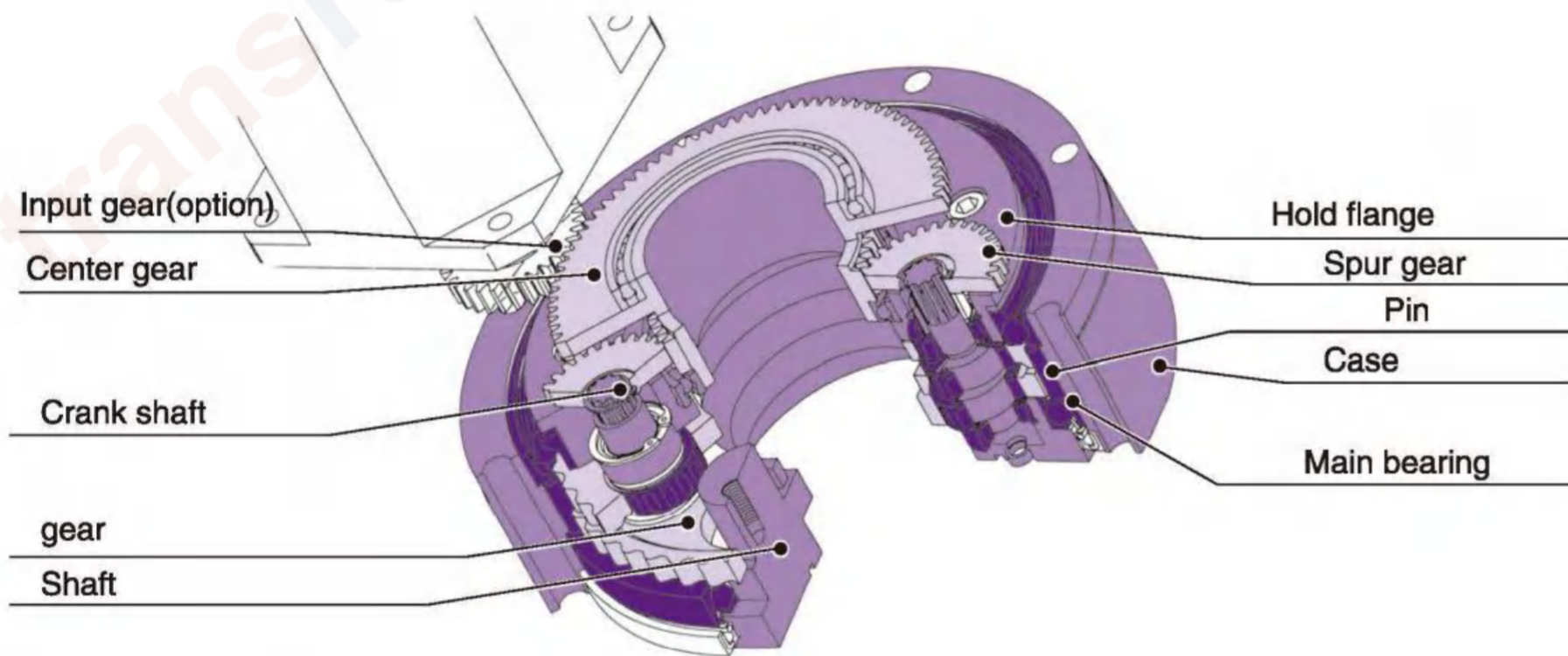

### Hollow shaft structure

- Cables and other lines can pass through the reduction gear
- Allows space saving design

### Integrated angular ball bearings

#### Benefits:

- Increases reliability
- Reduces overall cost

#### Attributed to:

- Built-in angular ball bearing construction improves the ability to support external loads and increases moment rigidity and maximum allowable moment. As a result, this model can be used for the rotary axis.
- Reduces the number of components required.
- Simplifies installation.

### 2-stage reduction

#### Benefits:

- Reduces vibration
- Reduces inertia ( $GD^2$ )

#### Attributed to:

- Low speed rotation of the RV gear reduces vibration.
- Reduced size of the motor coupling part (input gear) lowers inertia.

### All main elements are supported from both sides

#### Benefits:

- Higher torsional stiffness
- Less vibration
- High shock load capability (5 times rated torque)

#### Detail:

- Crankshafts are supported on both sides of the reduction gear as shown below.

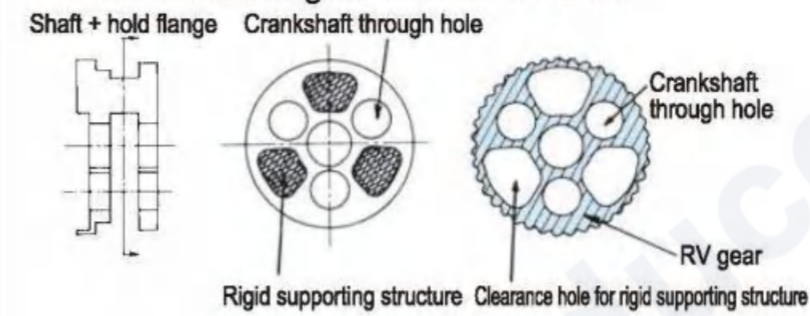

### Rolling contact elements

#### Benefits:

- Excellent starting efficiency
- Low wear and longer life
- Low backlash (1 arc. min.)

#### Attributed to:

- Use of roller bearings throughout.

### Pin & gear structure

#### Benefits:

- Very low backlash (1 arc. min.)
- Higher shock load capability (5 times rated torque)

#### Attributed to:

- Synchroneshing of many RV gear teeth and pins.

## RV-C Series

### Robot wrist axis

- Allows space-saving design
- Main bearing is not required on robot side.

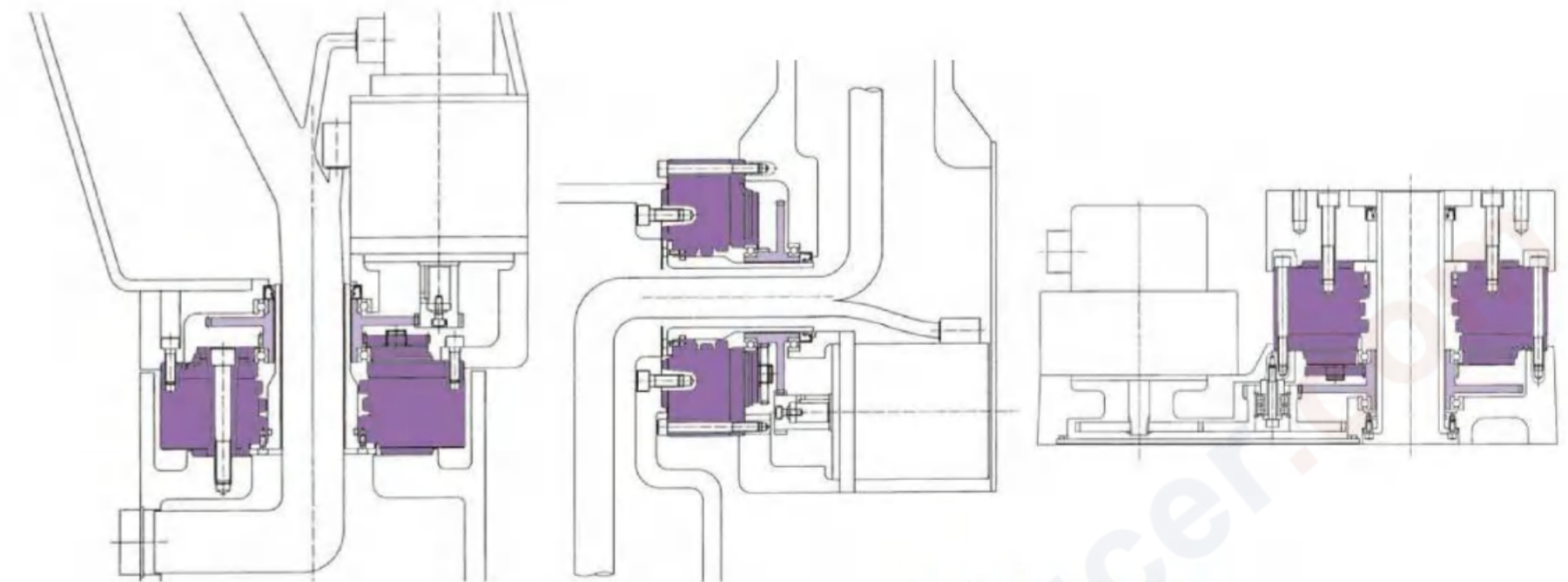

### Indexing table

- The table can be made into a hollow shaft structure.

### Robot arm

- As cables can be passed through the arm, environmental resistance increases.
- Wider operating angle.

## RV-C series rotary direction and speed ratio

Both the E series and Original series may be used in various ways. The following figures show six combinations of the rotary direction and speed ratio. Use the following figure to select a mechanism most suitable for your application.

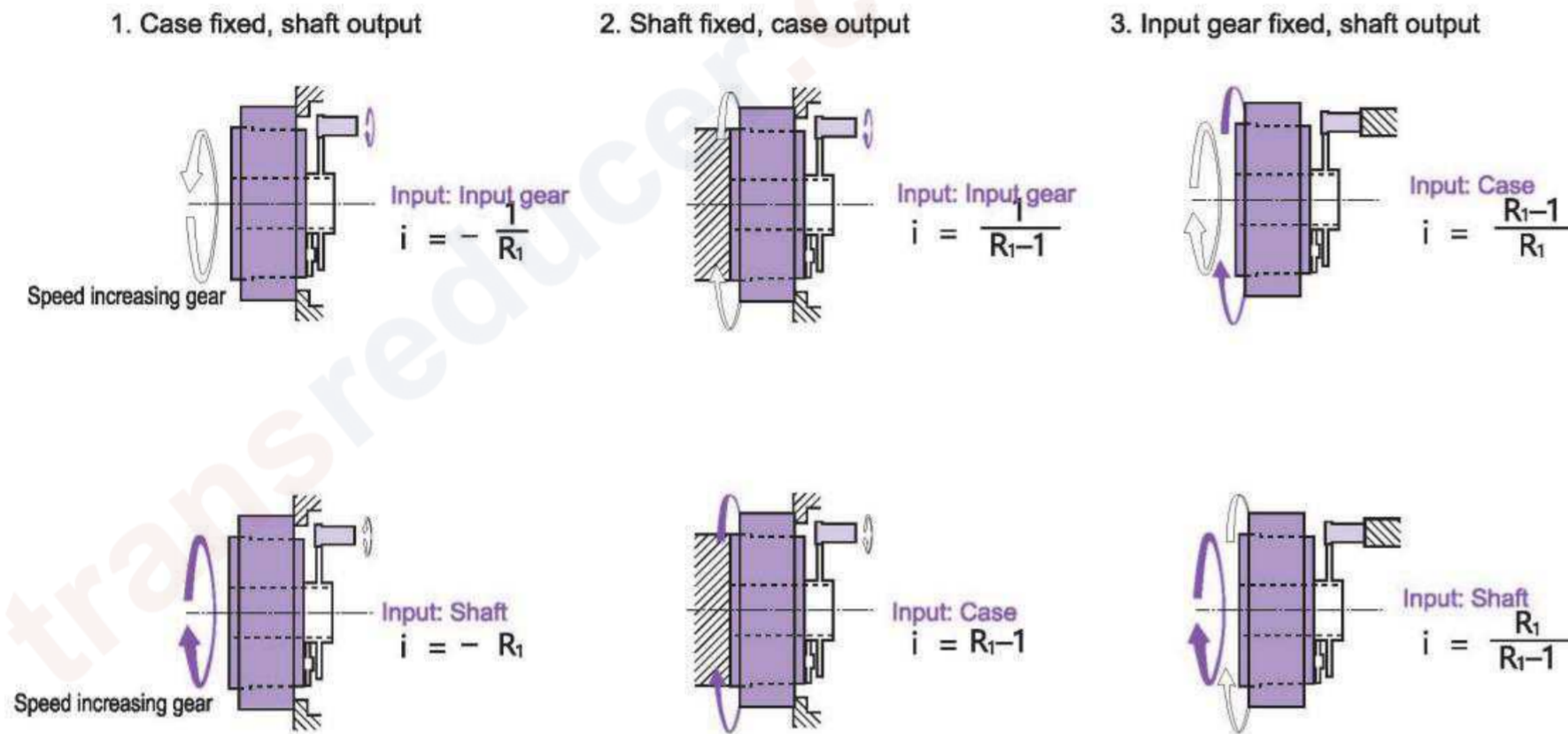

## Installation example (motor installed on case side of reduction gear)

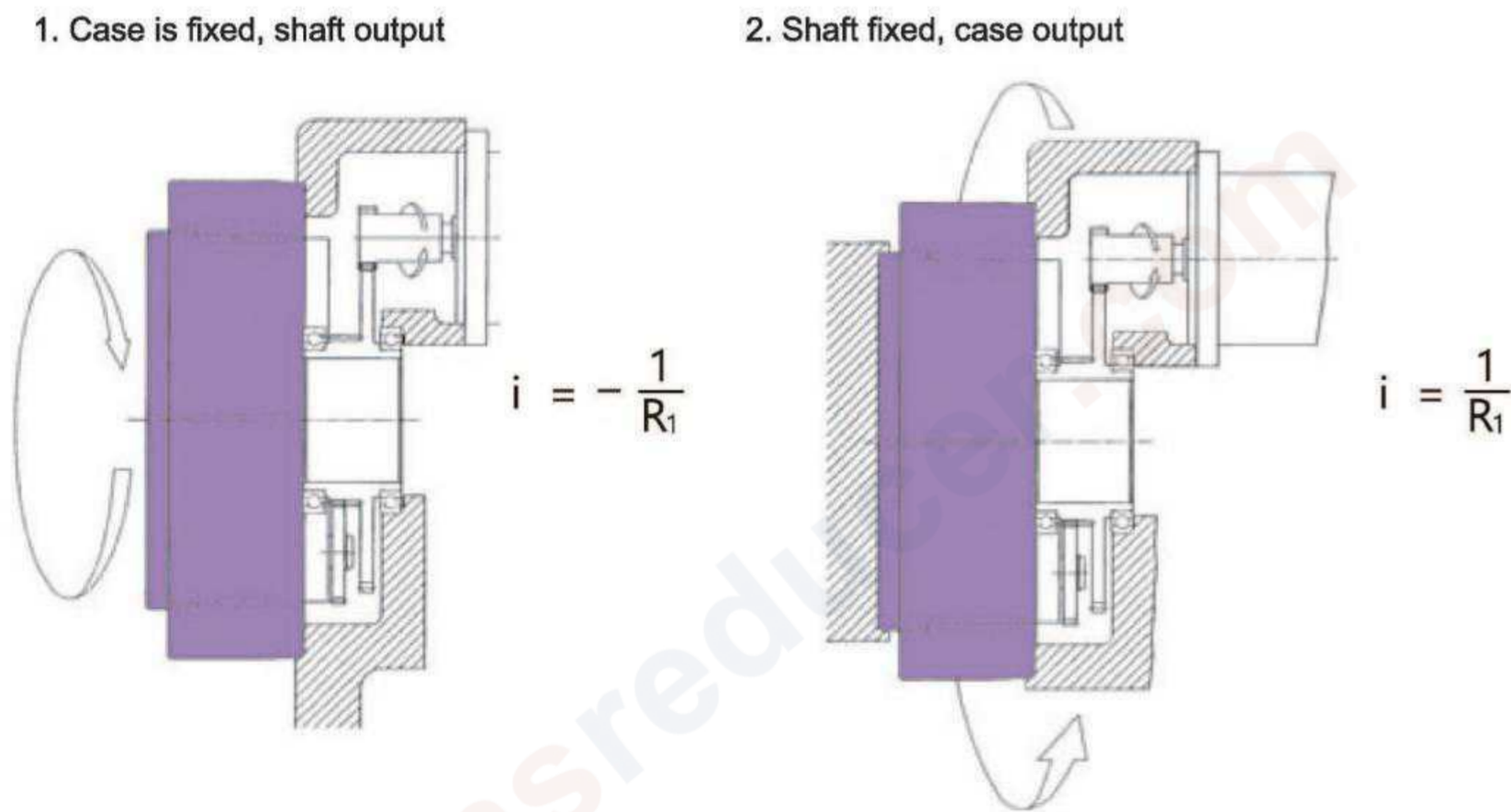

- The "i" in the above equations signifies the speed ratio of the output for the input in each case. The "+" signifies the output in the same direction as the input and the "-" signifies the output in the opposite direction to the input.
- The above figures show the situation when the motor is installed on the fixed side.

## RV-C Ratio

### Mechanism block drawing

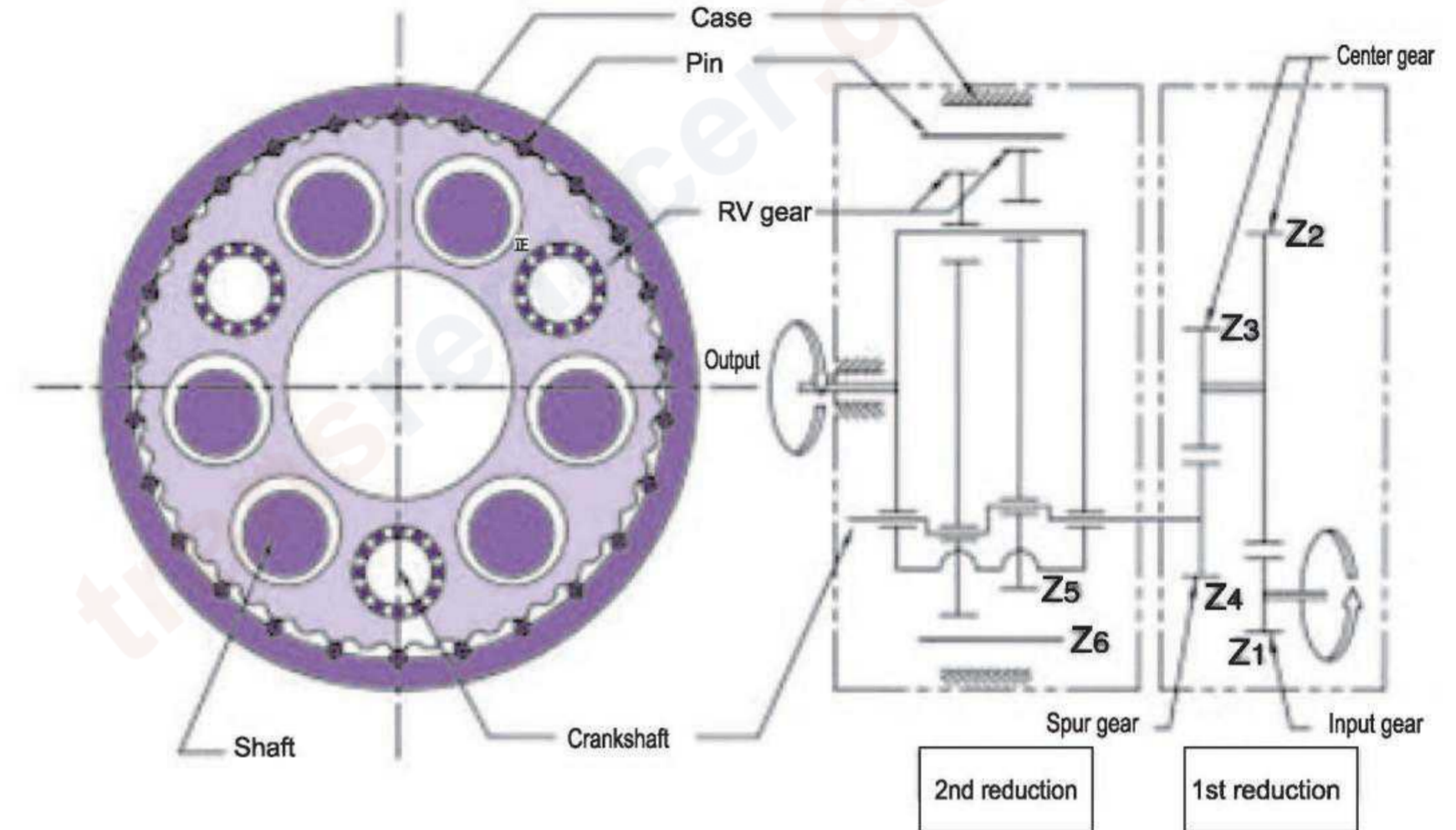

The overall reduction ratio  $i$  (of the First and Second reduction stages) will differ depending on the use, and can be calculated using the speed ratio values displayed in the table below.

With the shaft as output;

$$R = R_1 \times \frac{Z_2}{Z_1}$$

$$i = -\frac{1}{R}$$

$$(R_1 = 1 + \frac{Z_4}{Z_3} \cdot Z_6)$$

$R$  : Overall speed ratio

$R_1$  : Speed ratio of a discrete reduction gear

$Z_1$  : Number of teeth on input gear

$Z_2$  : Number of teeth on large center gear

$Z_3$  : Number of teeth on small center gear

$Z_4$  : Number of teeth on spur gear

$Z_5$  : Number of teeth on RV gear

$Z_6$  : Number of pins

$i$  : Reduction ratio

Note: The speed ratio values and rotation directions shown above indicate when the motor (motor fixing component) is installed on the case side of the reduction gear.

# RV-C Series Precision Robot Joints



## Principle of Speed Reduction

### 1st stage ...Spur gear reduction

- An input gear engages with and rotates spur gears that are coupled to crankshafts. Several overall gear ratios can be provided by selecting various first stage ratios.

### 2nd stage ...Epicyclic gear reduction

- Crankshafts driven by the spur gears cause an eccentric motion of two epicyclic gears called RV gears that are offset 180 degrees from one another to provide a balanced load.
- The eccentric motion of the RV gears causes engagement of the cycloidal shaped gear teeth with cylindrically shaped pins located around the inside edge of the case. In the course of one revolution of the crankshafts the teeth of the RV gear move the distance of one pin in the opposite direction of the rotating cranks. The motion of the RV gear is such that the teeth remain in close contact with the pins and multiple teeth share the load simultaneously.
- The output can be either the shaft or the case. If the case is fixed, the shaft is the output. If the shaft is fixed, the case is the output.

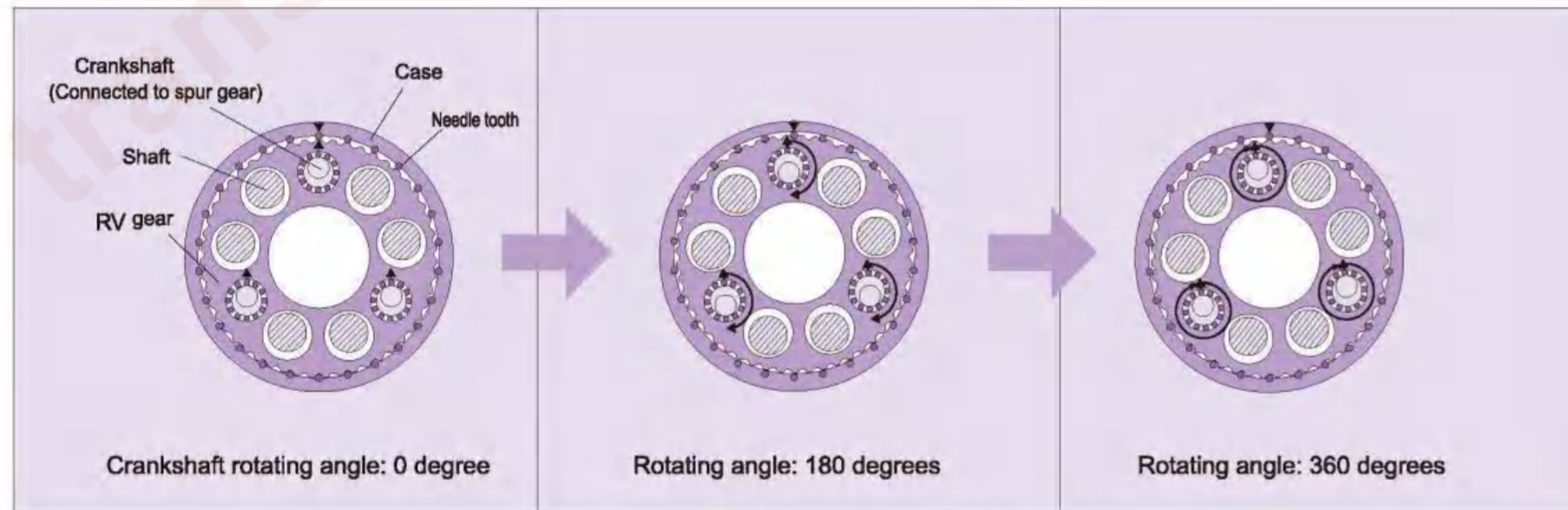

## RV-C Series Model Indication

- When placing an order or making an inquiry, please use the following codes to specify the appropriate model.

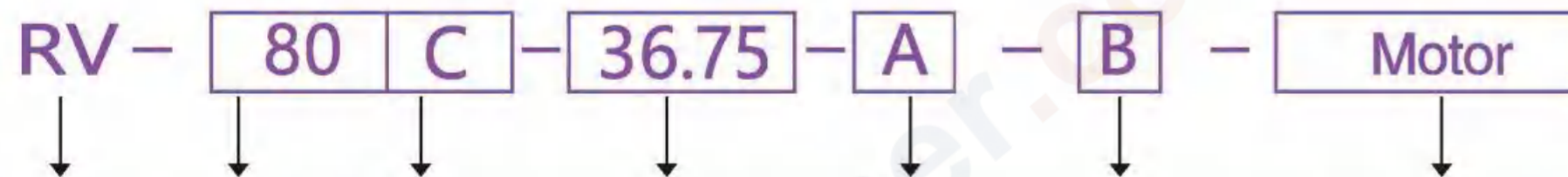

Model code	Frame number	Series code	Ratio code	Center gear code	Output shaft clamp code	Motor
RV	10	C: Hollow shaft type	27	A: Standard gear A Z: No gear	B: Bolt-clamping output shaft type T: Through-bolt clamping output shaft type	Motor
	27		36.57			
	50		32.54			
	100		36.75			
	200		34.86			
	320		35.61			
	500		37.34			

## Technical note

### Rated service life

The lifetime resulting from the operation with the rated torque and the rated output speed is referred to as the "rated service life"

### Allowable acceleration/deceleration torque

When the machine starts or stops, the load torque to be applied to the gearbox is larger than the constant-speed load torque due to the effect of the inertia torque of the rotating part. In such a situation, the allowable torque during acceleration/deceleration is referred to as "allowable acceleration/deceleration torque".  
Note: Be careful that the load torque, which is applied at startup and stop, does not exceed the allowable acceleration/deceleration torque.

### Momentary maximum allowable torque

When the machine results from emergency stop or external impact, the larger torque to be applied to gearbox. In such a situation, the allowable torque is referred to as momentary maximum allowable torque. A large torque may be applied to the gearbox due to execution of emergency stop or by an external shock. In such a situation, the allowable value of the momentary applied torque is referred to as "momentary maximum allowable torque".  
Note: Be careful that the momentary excessive torque does not exceed the momentary maximum allowable torque.

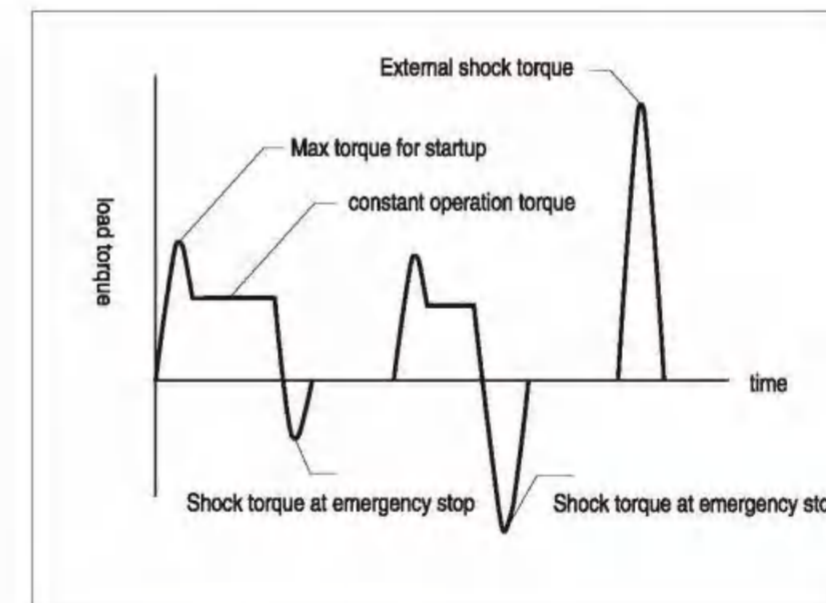

### Allowable output speed

The allowable value for the gearbox's output speed during operation without a load is referred to as the "allowable output speed".

Notes: Depending on the conditions of use (duty ratio, load, ambient temperature), the gearbox temperature may exceed 60° C even when the speed is under the allowable output speed. In such a case, either take cooling measures or use the gearbox at a speed that keeps the surface temperature at 60° C or lower.

### Duty ratio

The duty ratio is defined as the ratio of the sum total time of acceleration, constant, and deceleration to the cycle time of the gearbox.

### Torsional rigidity, lost motion, backlash

When a torque is applied to the output shaft while the input shaft is fixed, torsion is generated according to the torque value. The torsion can be shown in the hysteresis curves. The value of b/a is referred to as "torsional rigidity". The torsion angle at the mid point of the hysteresis curve width within ±3% of the rated torque is referred to as "lost motion". The torsion angle when the torque indicated by the hysteresis curve is equal to zero is referred to as "backlash".

< Hysteresis curve >

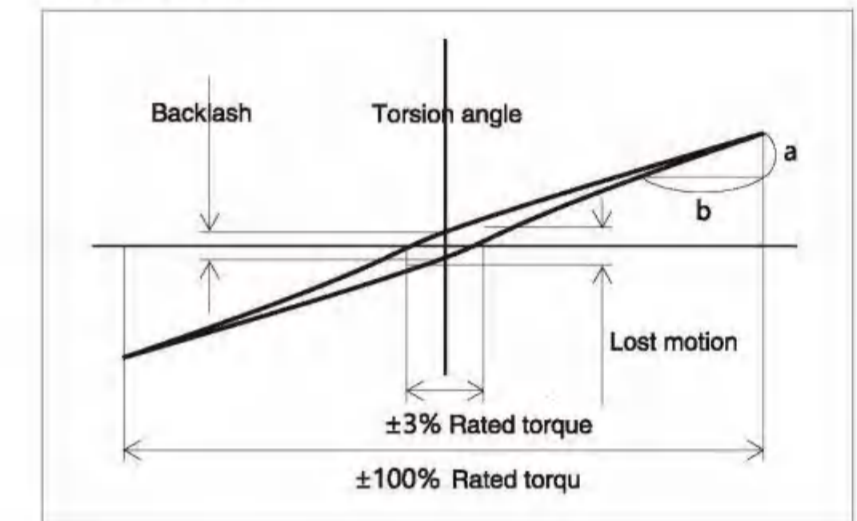

### Startup efficiency

The efficiency of the moment when the gearbox starts up is referred to as "startup efficiency".

### No-load running torque (input shaft)

The torque for the input shaft that is required to run the gearbox without load is referred to as "no-load running torque".

### Allowable moment and maximum thrust load

The external load moment may be applied to the gearbox during normal operation. The allowable values of the external moment and the external axial load at this time are each referred to as "allowable moment" and "maximum thrust load".

### Angular transmission error

The angular transmission error is defined as the difference between the theoretical output angle of rotation (when there are input instructions for an arbitrary rotation angle) and the actual output angle of rotation.

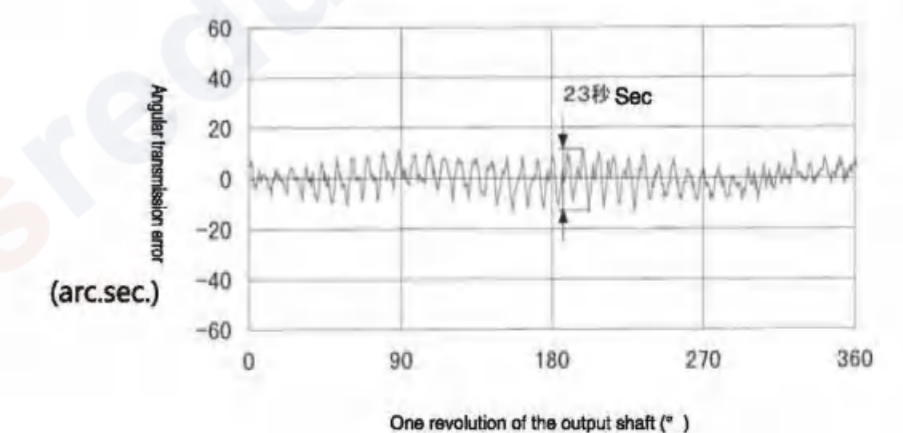

# RV-C series Rating Table

Type	Ratio code	Output speed (rpm)		Output torque (Nm) / Input capacity (kW)									
		R Speed ratio		5	10	15	20	25	30	40	50	60	
		Shaft rotation	Case rotation										
RV-10C	27	27	26	136 / 0.09	111 / 0.16	98 / 0.21	90 / 0.25	84 / 0.29	80 / 0.34	73 / 0.41	68 / 0.47	65 / 0.54	
RV-27C	36.57	1,390/38	1352/38	368 / 0.26	299 / 0.42	265 / 0.55	243 / 0.68	227 / 0.79	215 / 0.90	197 / 1.10	184 / 1.29	174 / 1.46	
RV-50C	32.54	1,985/61	1924/61	681 / 0.48	554 / 0.77	490 / 1.03	450 / 1.26	420 / 1.47	398 / 1.67	366 / 2.04	341 / 2.38		
RV-100C	36.75	36.75	35.75	1,362 / 0.95	1,107 / 1.55	980 / 2.05	899 / 2.51	841 / 2.94	796 / 3.33	730 / 4.08			
RV-200C	34.86	1,499/43	1456/43	2,724 / 1.90	2,215 / 3.09	1,960 / 4.11	1,803 / 5.04	1,686 / 5.88	1,597 / 6.69				
RV-320C	35.61	2,778/78	2700/78	4,361 / 3.04	3,538 / 4.94	3,136 / 6.57	2,881 / 8.05	2,690 / 9.41					
RV-500C	37.34	3,099/83	3016/83	6,811 / 4.75	5,537 / 7.73	4,900 / 10.26	4,498 / 12.56						

Note: 1. The allowable output speed will differ depending upon the duty ratio, load, and ambient temperature. Contact us regarding use above the allowable output speed Ns1.

2. The input capacity (kW) is calculated according to the following calculation formula:

$$\text{Input capacity (kW)} = \frac{2\pi \cdot N \cdot T}{60 \cdot \frac{\eta}{100} \cdot 10^3}$$

N: Output speed (rpm)  
T: Output torque (Nm)  
η = 75: Reduction gear efficiency (%)

Note: The input capacity is a reference value.

3. When the reduction gear is used at low temperatures, there will be a larger no-load running torque. Note this characteristic when selecting a motor. (Refer to "Low temperature characteristic" on page 93)

T <sub>0</sub> Rated torque (Note 7)	N <sub>0</sub> Rated output Speed	K Rated service life	T <sub>S1</sub> Allowable acceleration deceleration torque	T <sub>S2</sub> Momentary maximum allowable torque	N <sub>S0</sub> Maximum allowable output speed (Note 1)	Backlash	Lost motion MAX.	Angular transmission error MAX.	Startup efficiency (Typical value)	M <sub>01</sub> Allowable moment (Note 4)	M <sub>02</sub> Momentary allowable moment (Max.)	W <sub>r</sub> Allowable radial load (Note 9)	I Reduced value of the inertia moment for the input shaft (Note 5)	I (=GD <sup>2</sup> ) Inertia of center gear	Weight
(Nm)	(rpm)	(h)	(Nm)	(Nm)	(r/min)	(arcsec)	(arcmin)	(arcsec)	(%)	(Nm)	(Nm)	(N)	(kgm <sup>2</sup> )	(kgm <sup>2</sup> )	(kg)
98	15	6,000	245	490	80	1.0	1.0	70	75	686	1,372	5,755	1.38×10 <sup>-5</sup>	0.678×10 <sup>-3</sup>	4.6
264.6	15	6,000	662	1,323	60	1.0	1.0	70	80	980	1,960	6,520	0.550×10 <sup>-4</sup>	0.563×10 <sup>-3</sup>	8.5
490	15	6,000	1,225	Bolt joint 2,450 Through-bolt clamping 1,960	50	1.0	1.0	60	75	1,764	3,528	9,428	1.82×10 <sup>-4</sup>	0.363×10 <sup>-2</sup>	14.6
980	15	6,000	2,450	Bolt joint 4,900 Through-bolt clamping 3,430	40	1.0	1.0	50	80	2,450	4,900	11,802	0.475×10 <sup>-3</sup>	0.953×10 <sup>-2</sup>	19.5
1,960	15	6,000	4,900	Bolt joint 9,800 Through-bolt clamping 7,350	30	1.0	1.0	50	80	8,820	17,640	31,455	1.39×10 <sup>-3</sup>	1.94×10 <sup>-2</sup>	55.6
3,136	15	6,000	7,840	15,680	25	1.0	1.0	50	85	20,580	39,200	57,087	0.518×10 <sup>-2</sup>	0.405×10 <sup>-1</sup>	79.5
4,900	15	6,000	12,250	24,500	20	1.0	1.0	50	80	34,300	78,400	82,970	0.996×10 <sup>-2</sup>	1.014×10 <sup>-1</sup>	154

Note:

- The allowable moment will differ depending on the thrust load. Check the allowable moment diagram (p. 91).
- The inertia moment value is for the reduction gear. It does not include the inertia moment for the input gear.
- For the moment rigidity and torsional rigidity, refer to the calculation of tilt angle and the torsion angle (p. 99).
- The rated torque is the value that produces the rated service life based on operation at the rated output speed; it does not indicate the maximum load. Refer to the "Glossary" (p.81) and the "Product selection flowchart" (p.82).
- Contact us regarding speed ratios other than those listed above.
- The specifications above are based on Nabtesco evaluation methods; this product should only be used after confirming that it is appropriate for the operating conditions of your system.
- When radial load b is applied within dimension b, use the reduction gear within the allowable radial load.
- \*1 The R=153 for the RV-80E is only for the bolt-clamping output shaft type (page 20, 21).

RV-10C Bolt clamping output shaft type

Ratio  
Type RV-10C-27-A-B

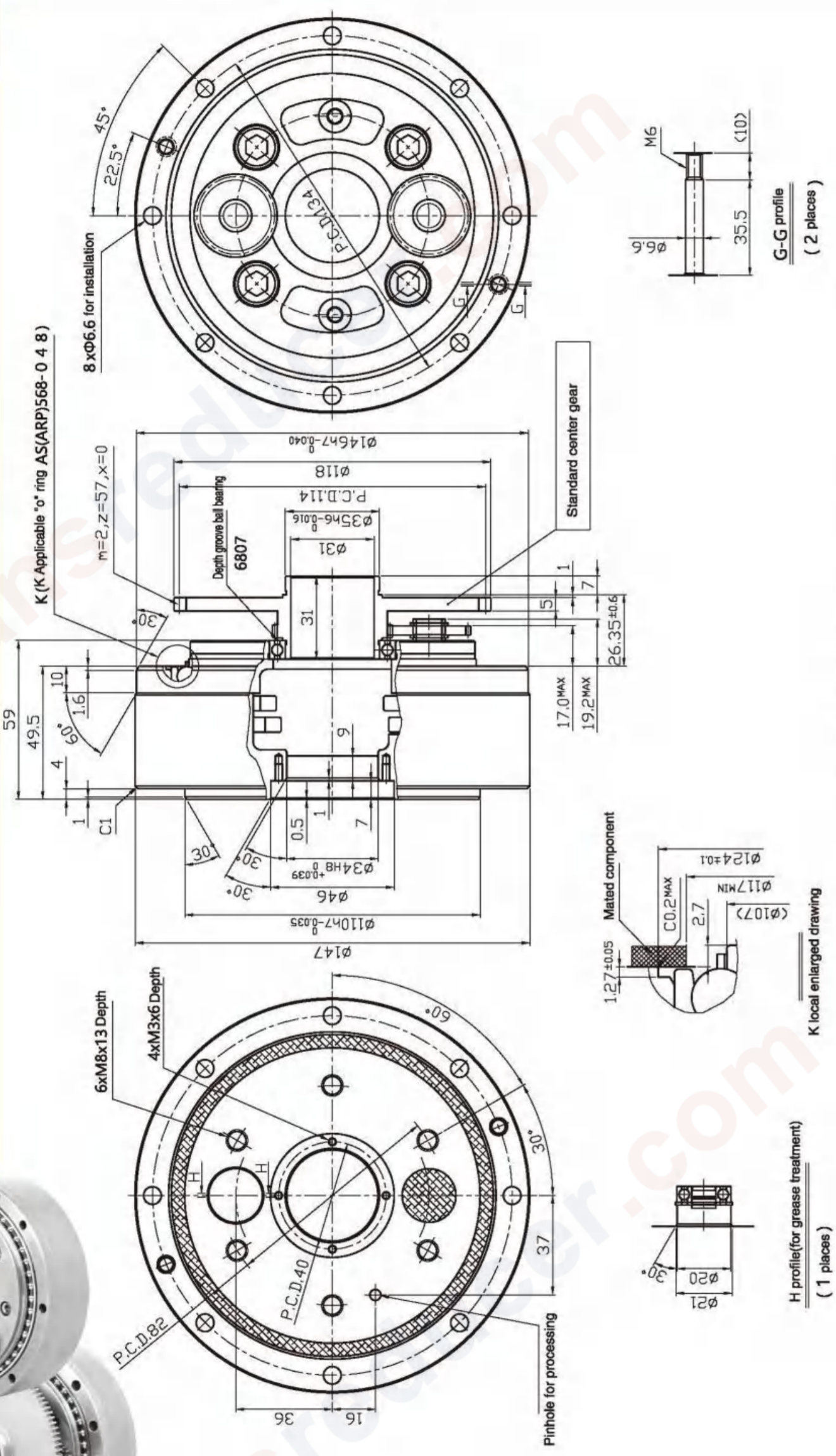
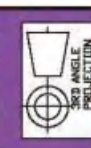

H profile (for grease treatment)  
( 1 places )

K local enlarged drawing

Allowable transmission torque

Allowable transmission torque	
Number and size of bolts	Allowable transmission torque
Shell side 8-M6	1058.4Nm
Shaft side 6-M8	882Nm

Note: 1) "O" type ring and screw bolt, washer for installation are to be provided by customer.  
2) Please forgive not to inform in advance for the anytime changes of specifications, sizes.

Specifications and sizes might be changed without any advanced announcement

RV-27C Bolt clamping output shaft type

Ratio  
Type RV-27C-36.57-A-B

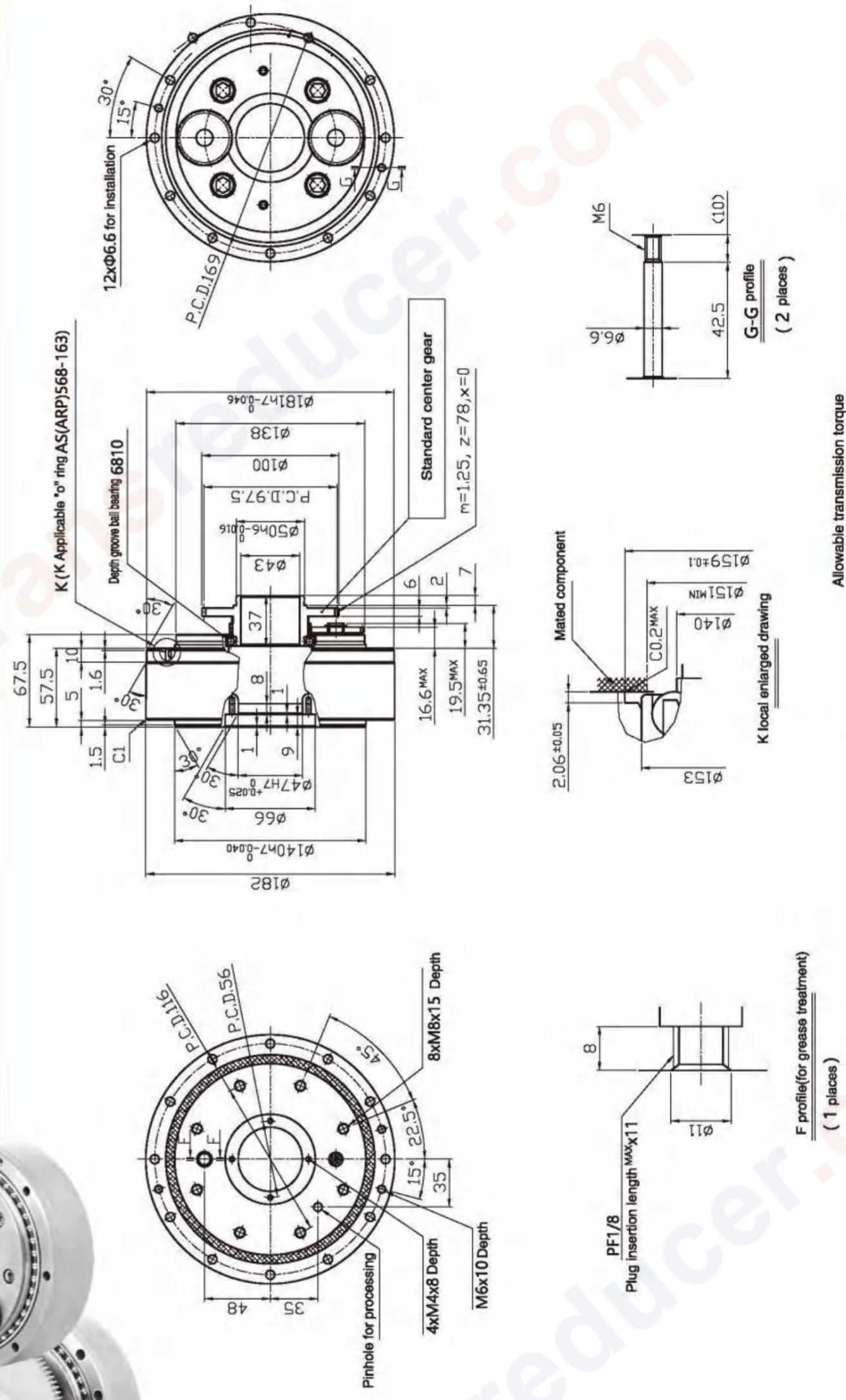
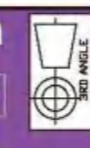

F profile (for grease treatment)  
( 1 places )

Allowable transmission torque

Allowable transmission torque	
Number and size of bolts	Allowable transmission torque
Shell side 12-M6	1999.2Nm
Shaft side 6-M8	1666Nm

Note: 1) "O" type ring and screw bolt, washer for installation are to be provided by customer.  
2) Please forgive not to inform in advance for the anytime changes of specifications, sizes.

Specifications and sizes might be changed without any advanced announcement









# RV-C Series Design Points Installation Components

## Installation procedure

- Typical installation examples for gearboxes to be mounted on the mating components are shown below. Be sure to apply the specified amount of the specified grease during assembly. Seals are required for the mounting surfaces of the center tube and gearbox.
- Refer to the O-ring seals shown to make a seal design of the mounting side.
- If O-ring (II) cannot be used due to the structure, apply the appropriate liquid sealant from the table on the right.
- If a seal cannot be formed by applying liquid sealants due to the structure, use O-ring (III) and (IV).

### Recommended liquid sealant

Manufacturer	Characteristics and applications
Three Bond 1211 (Three Bond)	<ul style="list-style-type: none"> <li>• Silicone-based, solventless type</li> <li>• Semi-dry gasket</li> </ul>
HERME SERL SS-60F (Nihon-Hermetics)	<ul style="list-style-type: none"> <li>• One-part, non-solvent elastic sealant</li> <li>• Metal contact side (flange surface) seal</li> <li>• Three Bond1211</li> <li>• Any product basically equivalent to ThreeBond 1211</li> </ul>
Loctite515 (Henkel)	<ul style="list-style-type: none"> <li>• Anaerobic flange sealant</li> <li>• Metal contact side (flange surface) seal</li> </ul>

- Notes 1. Do not use these sealants for copper material or copper alloy material.  
 2. If these sealants need to be used under special conditions such as concentrated alkali, pressurized steam, etc., please contact us.

## Assembly example of center tube

Centre tube is used to protect the grease passing through the hollow part and sealing the inside of the reducer. The following figure shows an example of an assembly reference for a centre tube.

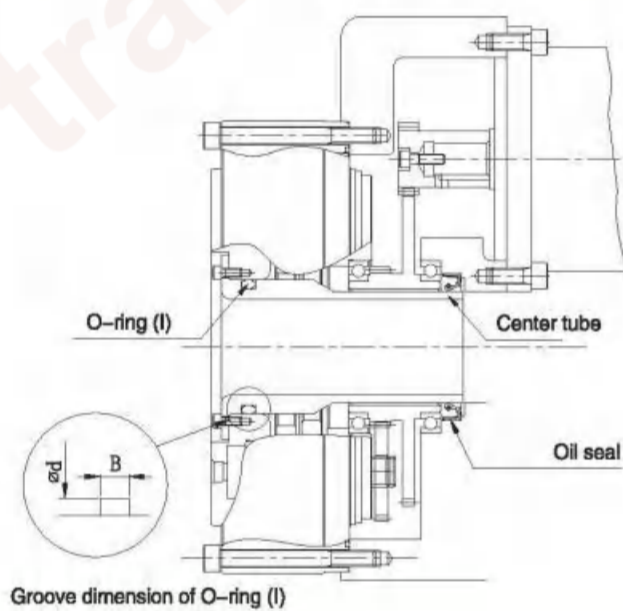

Dimensions for O-ring (I) seal(for reference) (Unit: mm)

	RV-10C	RV-27C	RV-50C
ID No.	CO 0625	CO 0634	CO 0643
Wire dia.	φ 2.4 ±0.07	←	φ 3.5 ±0.1
I. D.	φ 29.7	φ 42.2	φ 59.6
I. D.: d	φ 30.2 <sup>-0.08</sup>	φ 43.2 <sup>-0.08</sup>	φ 60.3 <sup>-0.10</sup>
Width B	3.2 <sup>+0.25</sup>	←	4.7 <sup>+0.25</sup>

(Unit: mm)

	RV-100C	RV-200C	RV-320C	RV-500C
ID No.	S70	G95	G135	G145
Wire dia.	φ 2.0 ±0.1	φ 3.1 ±0.1	←	←
I. D.	φ 69.5	φ 94.4	φ 134.4	φ 144.4
I. D.: d	φ 70.0 <sup>-0.05</sup>	φ 95.0 <sup>-0.10</sup>	φ 135.0 <sup>-0.08</sup>	φ 145.0 <sup>-0.10</sup>
Width B	2.7 <sup>+0.25</sup>	4.1 <sup>+0.25</sup>	←	←

## Assembly example with the output shaft bolt clamping type

(RV-10C, 27C, 50C, 100C, 200C, 320C, 500C)

If center tube, oil seal and O-ring (I) are used together, the seal on the mounting surface of output shaft side is not required.

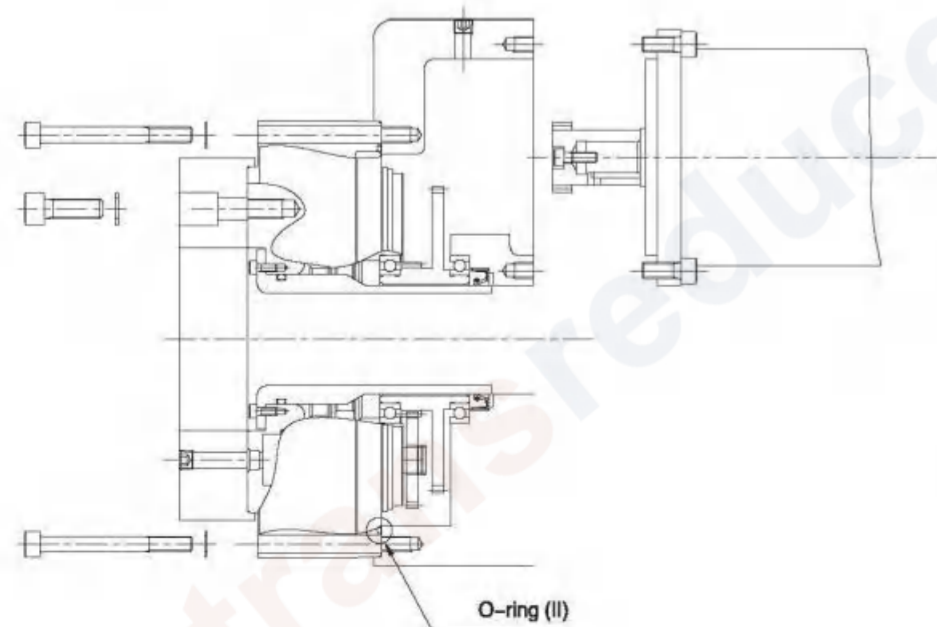

### O-ring (II)

	Applicable to O-ring
RV-10C	AS568-048
RV-27C	AS568-163
RV-50C	AS568-169
RV-100C	AS568-173
RV-200C	AS568-277
RV-320C	AS568-281
RV-500C	G460

The O-ring (II) can be applied to both bolt clamping and through-bolt clamping output shaft types.

## Assembly example of through-bolt clamping output shaft type

(RV-27C, RV-50C, 100C, 200C)

The O-ring groove is provided at the end face of output shaft of the reduction gear. Use O-rings as shown below.

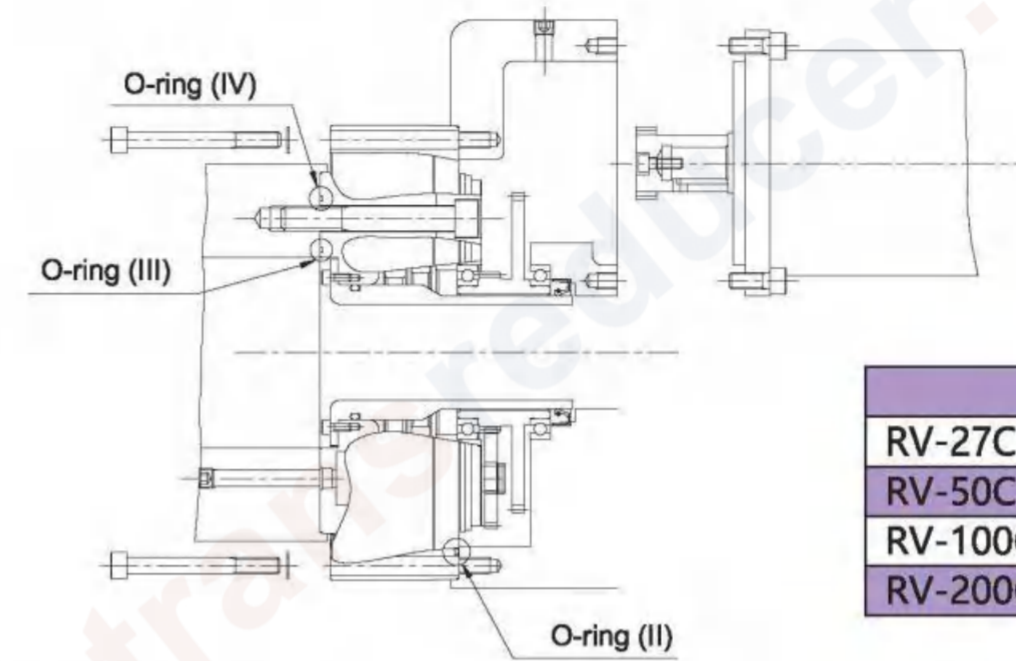

	Applicable to O-ring (III)	Applicable to O-ring (VI)
RV-27C	S75	S120
RV-50C	S100	S150
RV-100C	G115	AS568-165
RV-200C	S150	AS568-271

## Assembly example of through-bolt clamping output shaft type (RV-10C, 320C)

Provide the O-ring groove on the counterpart component. Dimensions of O-rings are shown below for reference.

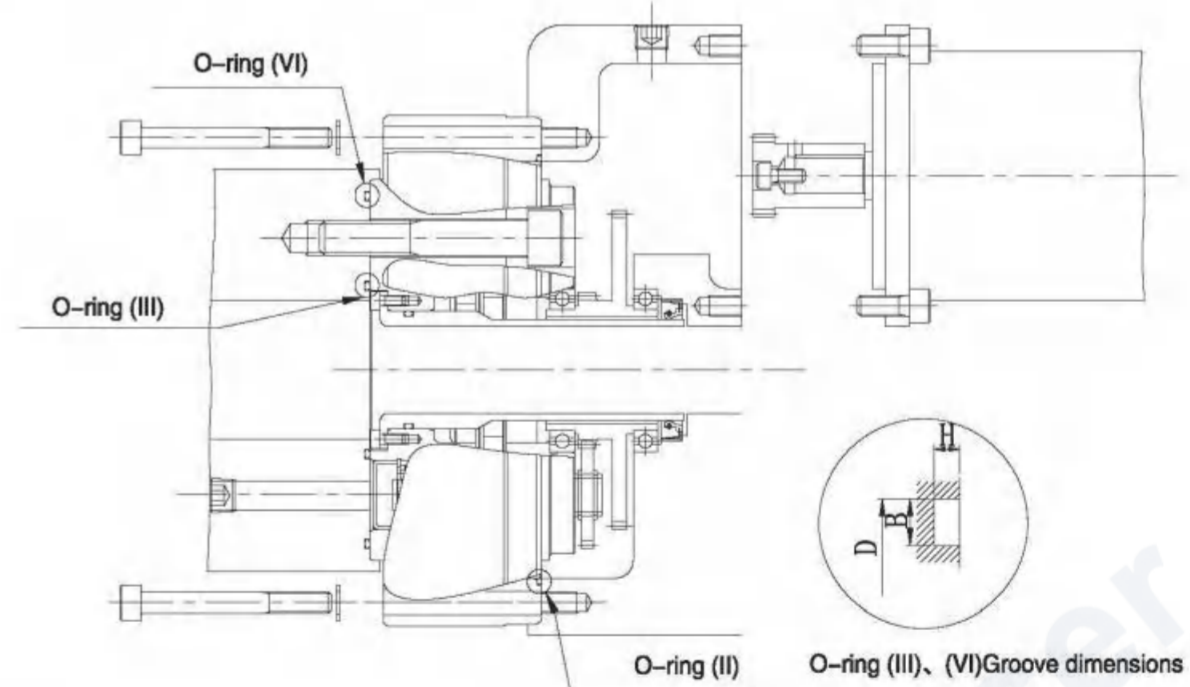

Dimensions for O-ring (I) seal(for reference) (Unit: mm)

	RV-10C	RV-320C
ID No.	AS568-032	G210
Wire dia.	φ 1.78 ±0.07	φ 5.7 ±0.13
I. D.	φ 47.35 ±0.38	φ 209.3
Outside dia. D	φ 51.0 <sup>+0.05</sup>	φ 220.0 <sup>+0.1</sup>
Depth H	1.27 ±0.05	5.5 ±0.05
Width B	2.39 <sup>+0.25</sup>	7.5 <sup>+0.25</sup>

Dimensions for O-ring (VI) seal(for reference) (Unit: mm)

	RV-10C	RV-320C
ID No.	S100	G290
Wire dia.	φ 2.0 ±0.1	φ 5.7 ±0.13
I. D.	φ 99.5 ±0.4	φ 289.3
Outside dia. D	φ 103.0 <sup>+0.05</sup>	φ 300.0 <sup>+0.1</sup>
Depth H	1.5 <sup>-0.1</sup>	5.5 ±0.05
Width B	2.7 <sup>+0.25</sup>	7.5 <sup>+0.25</sup>

Note: The S type ID number is the manufacturer's own standard.

# RV-EM Series model Indication



When placing an order or making an inquiry, please use the following codes to specify the appropriate model.



Model code	Frame number	Series code	Ratio code	Input gear code Input spline code	Output shaft clamp code	Motor
RV	6	E: Main bearing built-in type	31, 43, 53.5, 59, 79, 103	A: Standard gear A B: Standard gear B Z: No gear	B: Bolt-clamping output shaft type P: Pin/bolt clamping output shaft type	Motor Model
	20		57, 81, 105, 121, 141, 161			
	40		57, 81, 105, 121, 153			
	80		57, 81, 101, 121, 153			
	110		81, 111, 161, 175			
	160		81, 101, 129, 145, 171			
	320		81, 101, 118.5, 129, 141, 171, 185			
	450		81, 101, 118.5, 129, 154.8, 171, 192.4			

## RV-EM Series

Diagram for installation and disassembly of reducer

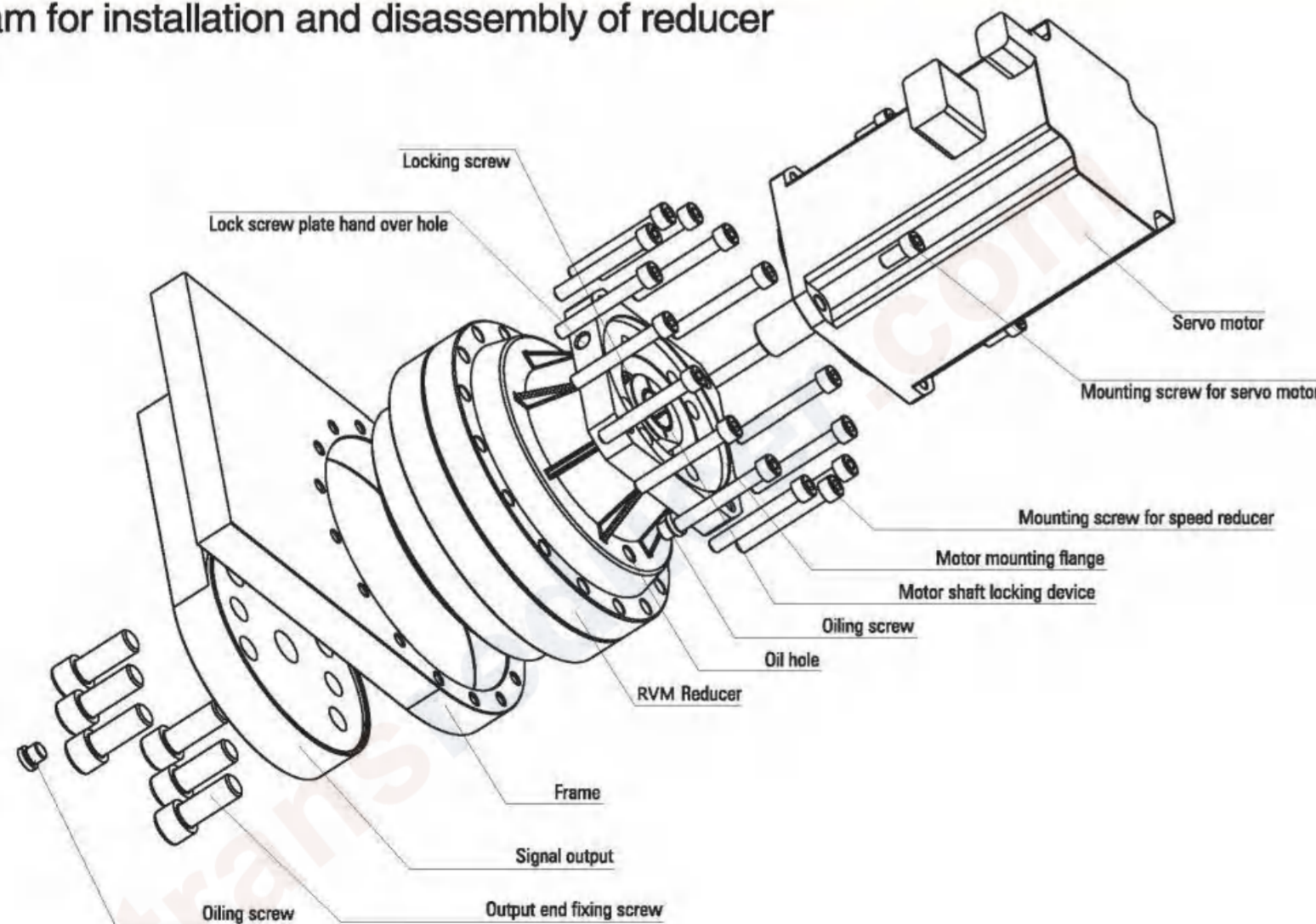

# RV-EM Series working principle



- Rotation of the servomotor is transmitted through the input gear to the spur gears, and the speed is reduced accordingly with the gear ratio between the input gear and the spur gears <Fig. 1>.   
※The hollow series is transmitted from the input gear to the spur gear through the central gear.
- Since they are directly connected, the crankshafts have the same rotational speed as the spur gears <Fig. 1>.
- Two RV gears are mounted around the needle bearings on the eccentric region of the crankshaft. (In order to balance the equal amount of force, two RV gears are mounted) <Fig. 2>.
- When the crankshafts rotate, the RV gears mounted on the eccentric sections also revolve eccentrically around the input axis (crank movement) <Fig. 2>.
- Pins are arrayed in a constant pitch in the grooves inside the case. The number of pins is just one larger than the number of RV teeth <Fig. 3>.
- As the crankshafts revolve one complete rotation, the RV gears revolve eccentrically one pitch of a pin (crank movement). As a result of this, the RV gears rotate one tooth in the direction opposite to the rotation of the crankshafts <Fig. 3>.
- The rotation is then transmitted to the shaft (output shaft) via the crankshaft. At this time, the shaft rotation speed can be reduced in proportion to the number of pins against the crankshaft. This is the second reduction section <Fig. 3>.
- The total reduction ratio is the product of the first reduction ratio multiplied by the second reduction ratio.   
※ Hollow series include reduction ratio of the centre gear section.

Fig. 1 First reduction section

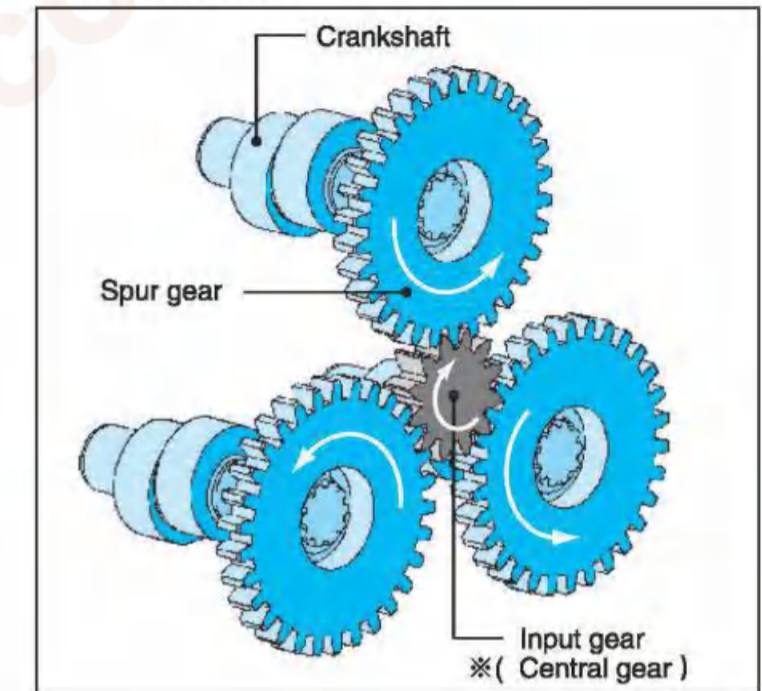

Fig. 2 Crankshaft section

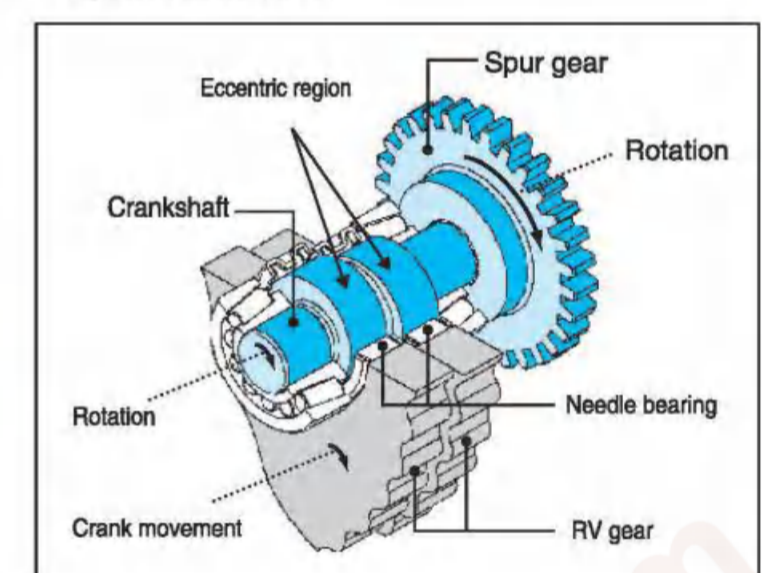
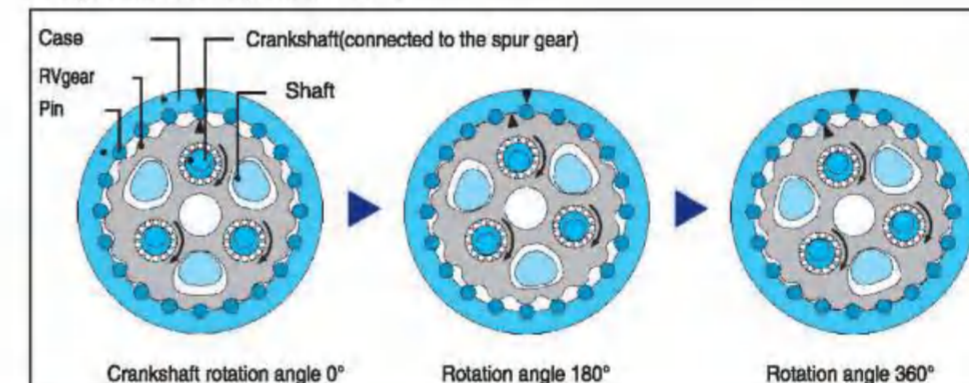
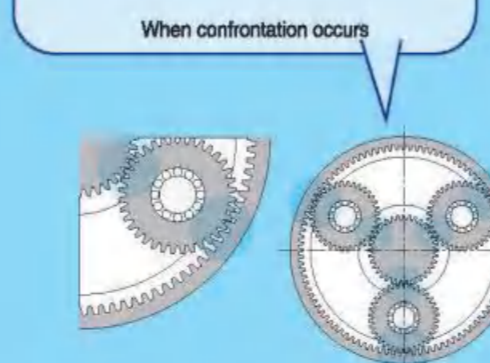
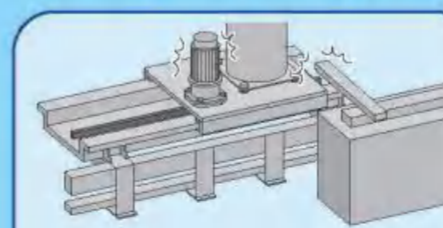

Fig. 3 Second reduction section



### Standard planetary gear

Low meshing rate and weak impact resistance



Gearbox is damaged when subjected to impact

### RV-EM series

Using pin gear mechanism, meshing rate and impact resistance are improved.



High reliability of the device

# RV-EM Series Rating Table

Type	Ratio code	Output speed (rpm)		Output torque (Nm) / Input capacity (kW)										
		R Speed ratio		5	10	15	20	25	30	40	50	60		
		Shaft rotation	Case rotation											
RV-6EM	31	31	30	101 / 0.07	81 / 0.11	72 / 0.15	66 / 0.19	62 / 0.22	58 / 0.25	54 / 0.30	50 / 0.35	47 / 0.40		
	43	43	42											
	53.5	53.5	52.5											
	59	59	58											
	79	79	78											
RV-20EM	103	103	102	231 / 0.16	188 / 0.26	167 / 0.35	153 / 0.43	143 / 0.50	135 / 0.57	124 / 0.70	115 / 0.81	110 / 0.92		
	57	57	56											
	81	81	80											
	105	105	104											
	121	121	120											
RV-40EM	141	141	140	572 / 0.40	465 / 0.65	412 / 0.86	377 / 1.05	353 / 1.23	334 / 1.40	307 / 1.71	287 / 2.00	271 / 2.27		
	161	161	160											
	57	57	56											
	81	81	80											
	105	105	104											
RV-80EM	121	121	120	1,088 / 0.76	885 / 1.24	784 / 1.64	719 / 2.01	672 / 2.35	637 / 2.67	584 / 3.26	546 / 3.81	517 / 4.33		
	153	153	152											
	57	57	56											
	81	81	80											
	101	101	100											
RV-110EM	121	121	120	1,499 / 1.05	1,215 / 1.70	1,078 / 2.26	990 / 2.76	925 / 3.23	875 / 3.67	804 / 4.49				
	153	*1 (153)	*1 (152)											
	57	57	56											
	81	81	80											
	111	111	110											
RV-160EM	161	161	160	2,176 / 1.52	1,774 / 2.48	1,568 / 3.28	1,441 / 4.02	1,343 / 4.69	1,274 / 5.34					
	175	1227/7	1220/7											
	57	57	56											
	81	81	80											
	101	101	100											
RV-320EM	129	129	128	4,361 / 3.04	3,538 / 4.94	3,136 / 6.57	2,881 / 8.05	2,695 / 9.41	2,548 / 10.7					
	141	141	140											
	171	171	170											
	185	185	184											
	81	81	80											
RV-450EM	101	101	100	6,135 / 4.28	4,978 / 6.95	4,410 / 9.24	4,047 / 11.3	3,783 / 13.2						
	118.5	118.5	117.5											
	129	129	128											
	154.8	2013/13	2000/13											
	171	171	170											
192	1347/7	1340/7												

Note: 1. The allowable output speed will differ depending upon the duty ratio, load, and ambient temperature. Contact us regarding use above the allowable output speed N<sub>s1</sub>.

2. The input capacity (kW) is calculated according to the following calculation formula:

$$\text{Input capacity (kW)} = \frac{2\pi \cdot N \cdot T}{60 \cdot \frac{\eta}{100} \cdot 10^3}$$

N: Output speed (rpm)  
T: Output torque (Nm)  
η = 75: Reduction gear efficiency (%)

Note: The input capacity is a reference value.

3. When the reduction gear is used at low temperatures, there will be a larger no-load running torque. Note this characteristic when selecting a motor. (Refer to "Low temperature characteristic" on page 93)

T <sub>0</sub> Rated torque (Note 7)	N <sub>0</sub> Rated output Speed	K Rated service life	T <sub>S1</sub> Allowable acceleration deceleration torque	T <sub>S2</sub> Momentary maximum allowable torque	N <sub>S0</sub> Maximum allowable output speed (Note 1)	Backlash	Lost motion MAX.	Angular transmission error MAX.	Startup efficiency (Typical value)	M <sub>01</sub> Allowable moment (Note 4)	M <sub>02</sub> Momentary allowable moment (Max.)	W <sub>r</sub> Allowable radial load (Note 10)	I Reduced value of the inertia moment for the input shaft (Note 5)	Weight
(Nm)	(rpm)	(h)	(Nm)	(Nm)	(r/min)	(arc.sec)	(arc.min)	(arc.sec)	(%)	(Nm)	(Nm)	(N)	(kgm <sup>2</sup> )	(kg)
58	30	6,000	117	294	100	1.5	1.5	80	70	196	392	2,140	2.63×10 <sup>-6</sup> 2.00×10 <sup>-6</sup> 1.53×10 <sup>-6</sup> 1.39×10 <sup>-6</sup> 1.09×10 <sup>-6</sup> 0.74×10 <sup>-6</sup>	2.5
167	15	6,000	412	833	75	1.0	1.0	70	75	882	1,764	7,785	9.66×10 <sup>-6</sup> 6.07×10 <sup>-6</sup> 4.32×10 <sup>-6</sup> 3.56×10 <sup>-6</sup> 2.88×10 <sup>-6</sup> 2.39×10 <sup>-6</sup>	4.7
412	15	6,000	1,029	2,058	70	1.0	1.0	60	85	1,666	3,332	11,594	3.25×10 <sup>-5</sup> 2.20×10 <sup>-5</sup> 1.63×10 <sup>-5</sup> 1.37×10 <sup>-5</sup> 1.01×10 <sup>-5</sup>	9.3
784	15	6,000	1,960	Bolt joint 3,920 Pin/bolt joint 3,185	70	1.0	1.0	50	85	Bolt joint 2,156 Pin/bolt joint 1,735	Bolt joint 4,312 Pin/bolt joint 2,156	Bolt joint 12,988 Pin/bolt joint 10,452	8.16×10 <sup>-5</sup> 6.00×10 <sup>-5</sup> 4.82×10 <sup>-5</sup> 3.96×10 <sup>-5</sup> 2.98×10 <sup>-5</sup>	Bolt joint 13.1 Pin/bolt joint 12.7
1,078	15	6,000	2,695	5,390	50	1.0	1.0	50	85	2,940	5,880	16,648	9.88×10 <sup>-5</sup> 6.96×10 <sup>-5</sup> 4.36×10 <sup>-5</sup> 3.89×10 <sup>-5</sup>	17.4
1,568	15	6,000	3,920	Bolt joint 7,840 Pin/bolt joint 6,615	45	1.0	1.0	50	85	3,920	Bolt joint 7,840 Pin/bolt joint 6,762	18,587	1.77×10 <sup>-4</sup> 1.40×10 <sup>-4</sup> 1.06×10 <sup>-4</sup> 0.87×10 <sup>-4</sup> 0.74×10 <sup>-4</sup>	26.4
3,136	15	6,000	7,840	Bolt joint 15,680 Pin/bolt joint 12,250	35	1.0	1.0	50	80	Bolt joint 7,056 Pin/bolt joint 6,174	Bolt joint 14,112 Pin/bolt joint 10,976	Bolt joint 28,067 Pin/bolt joint 24,558	4.83×10 <sup>-4</sup> 3.79×10 <sup>-4</sup> 3.15×10 <sup>-4</sup> 2.84×10 <sup>-4</sup> 2.54×10 <sup>-4</sup> 1.97×10 <sup>-4</sup> 1.77×10 <sup>-4</sup>	44.3
4,410	15	6,000	11,025	Bolt joint 22,050 Pin/bolt joint 18,620	25	1.0	1.0	50	85	8,820	Bolt joint 17,640 Pin/bolt joint 13,524	30,133	8.75×10 <sup>-4</sup> 6.91×10 <sup>-4</sup> 5.75×10 <sup>-4</sup> 5.20×10 <sup>-4</sup> 4.12×10 <sup>-4</sup> 3.61×10 <sup>-4</sup> 3.07×10 <sup>-4</sup>	66.4

Note:

- The allowable moment will differ depending on the thrust load. Check the allowable moment diagram (p. 91).
- The inertia moment value is for the reduction gear. It does not include the inertia moment for the input gear.
- For the moment rigidity and torsional rigidity, refer to the calculation of tilt angle and the torsion angle (p. 99).
- The rated torque is the value that produces the rated service life based on operation at the rated output speed; it does not indicate the maximum load. Refer to the "Glossary" (p.81) and the "Product selection flowchart" (p.82).
- Contact us regarding speed ratios other than those listed above.
- The specifications above are based on Nabtesco evaluation methods; this product should only be used after confirming that it is appropriate for the operating conditions of your system.
- When radial load b is applied within dimension b, use the reduction gear within the allowable radial load.
- \*1 The R=153 for the RV-80E is only for the bolt-clamping output shaft type (page 20, 21).

# RV-EM Series

## Reducer Installation Drawing

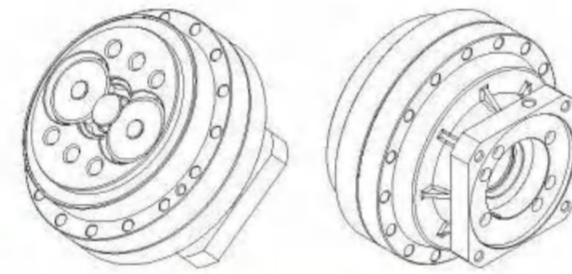
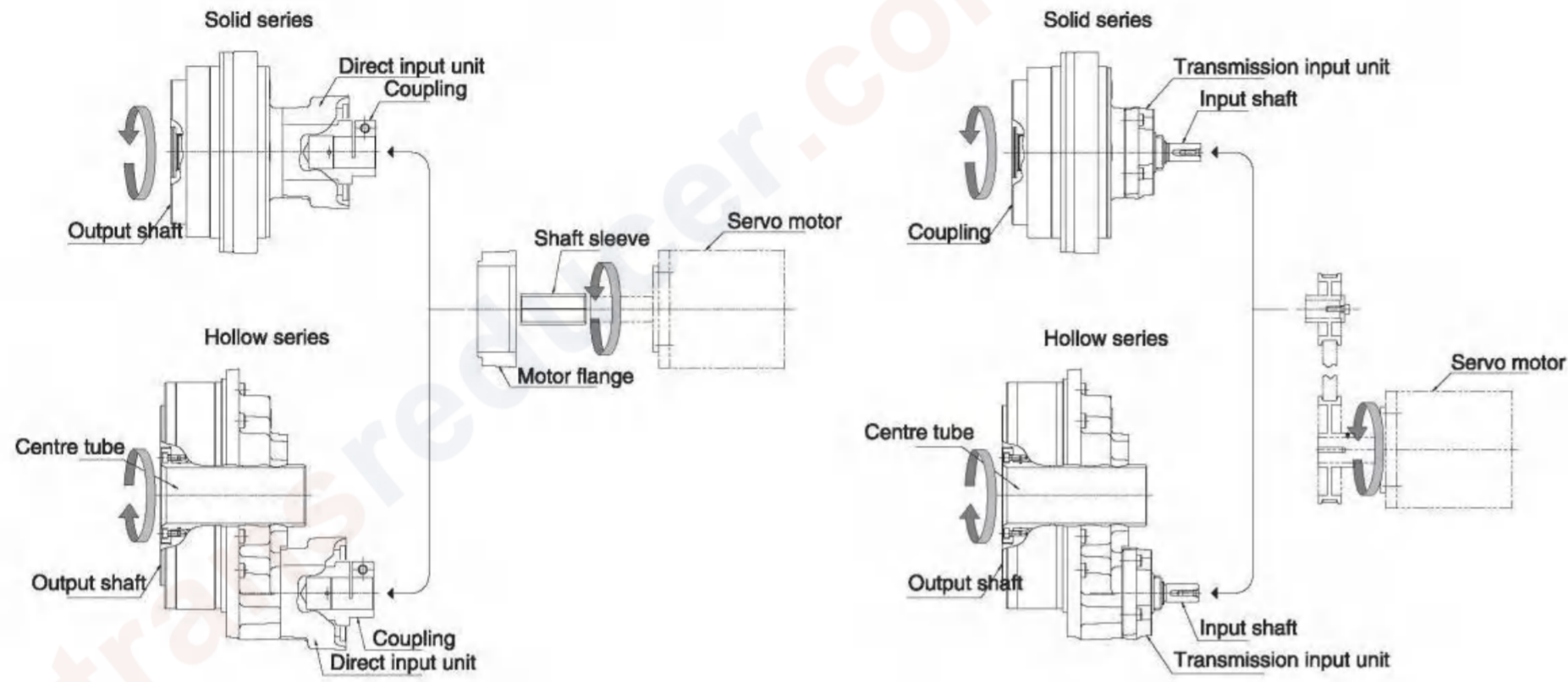

# RV-20EM-(19 Shaft)

## Overall Dimension Drawing

Output

Input

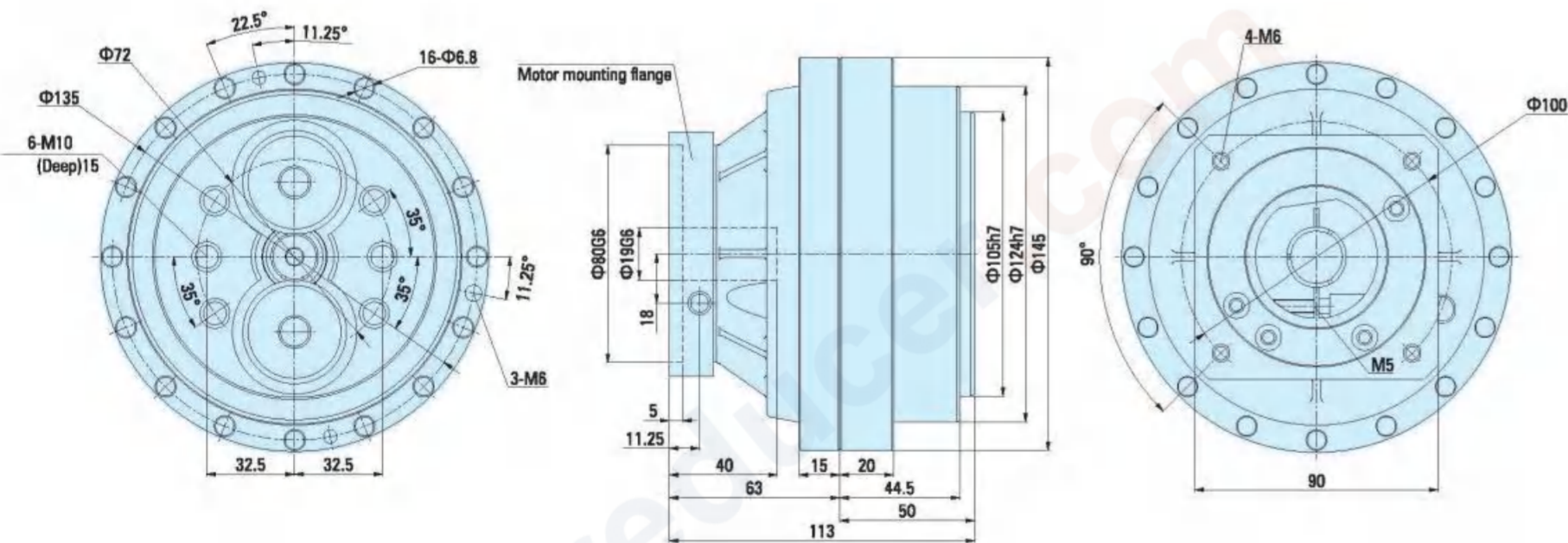

- Note:
  - This figure applies to the motor shaft:  $\leq 19 \times 40L$ ; motor shaft lock use locker.
  - Motor mounting flange according to motor model.

# RV-40EM-(19 Shaft)

## Overall Dimension Drawing

Output

Input

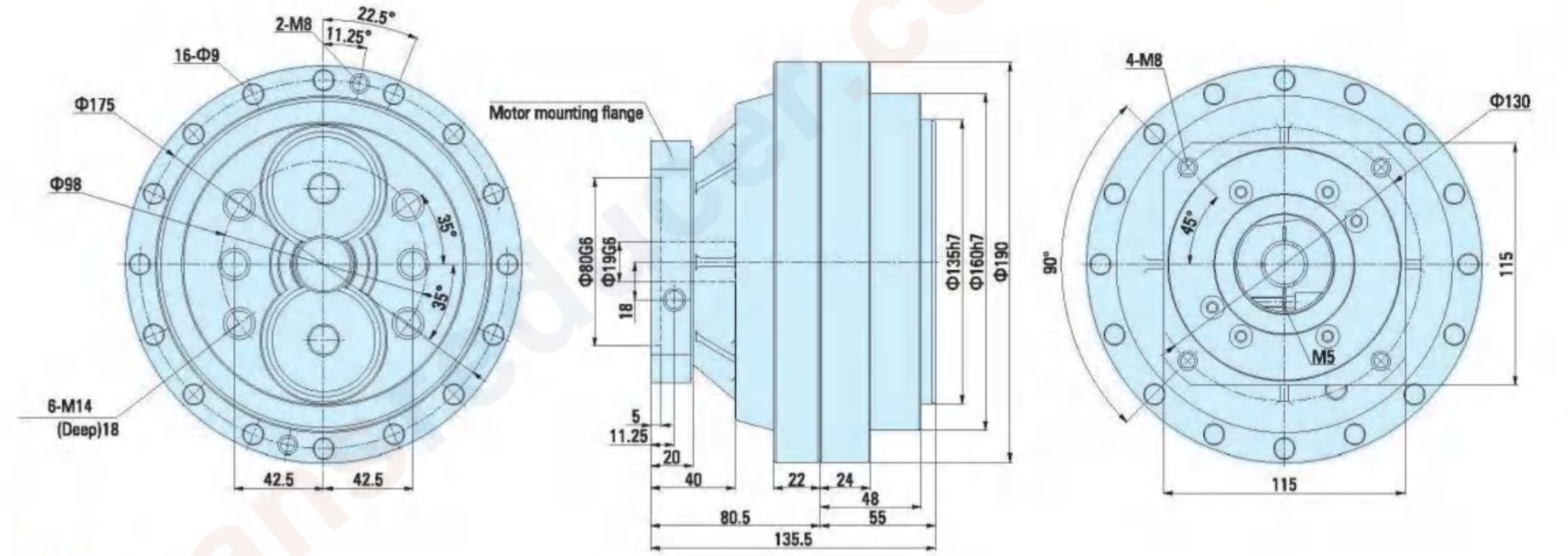

- Note:
  - This figure applies to the motor shaft:  $\leq 19 \times 40L$ ; motor shaft lock use locker.
  - Motor mounting flange according to motor model.

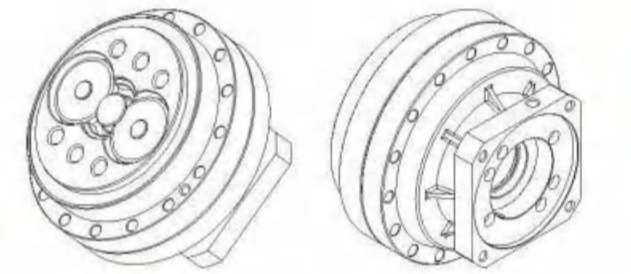

# RV-40EM-(24 Shaft)

## Overall Dimension Drawing

Output

Input

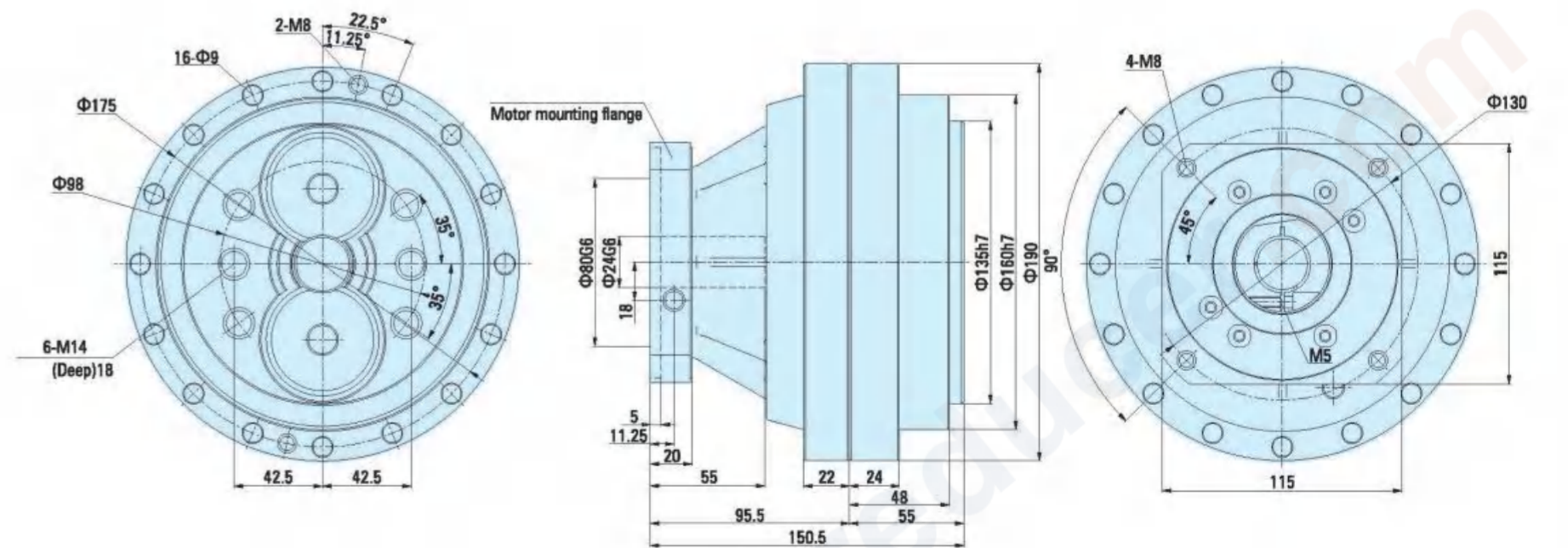

- Note:
  - This figure applies to the motor shaft:  $\leq 24 \times 55L$ ; motor shaft lock use locker.
  - Motor mounting flange according to motor model.

## RV-80EM-(24 Shaft)

### Overall Dimension Drawing



#### Output

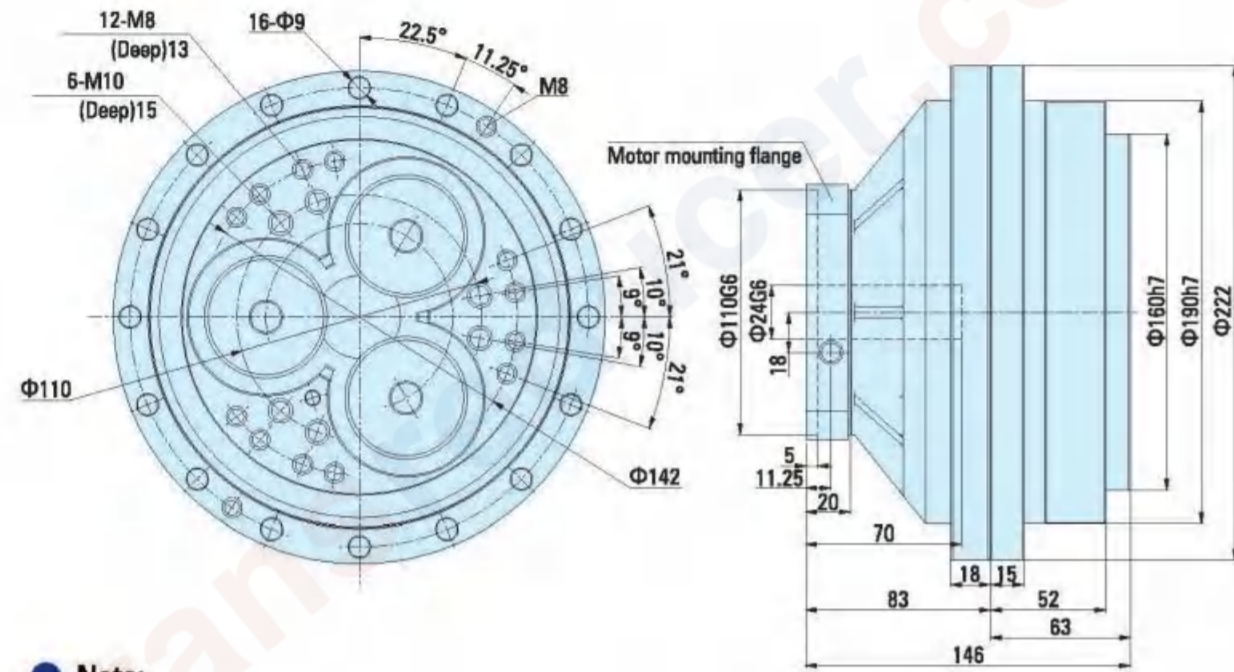

#### Input

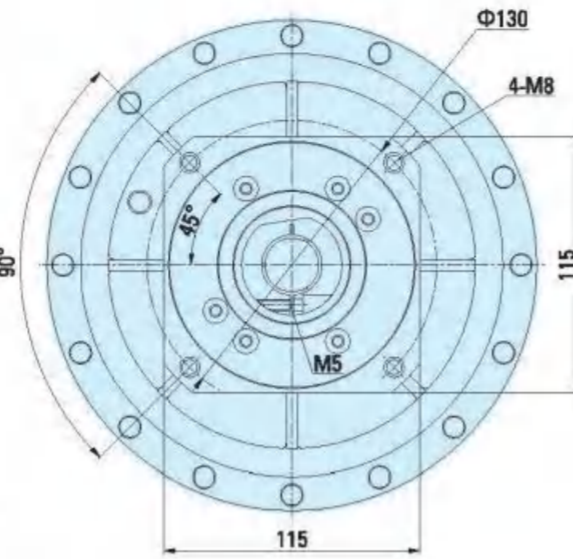

● Note:

1. This figure applies to the motor shaft:  $\leq 24 \times 70L$ ; motor shaft lock use locker.
2. Motor mounting flange according to motor model.

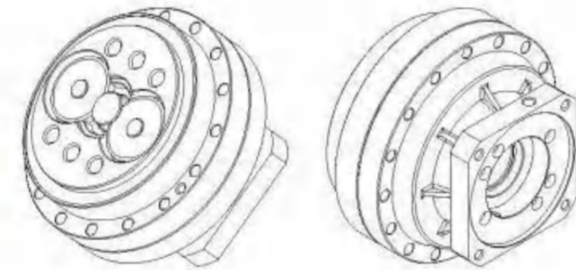

## RV-80EM-(35 Shaft)

### Overall Dimension Drawing

#### Output

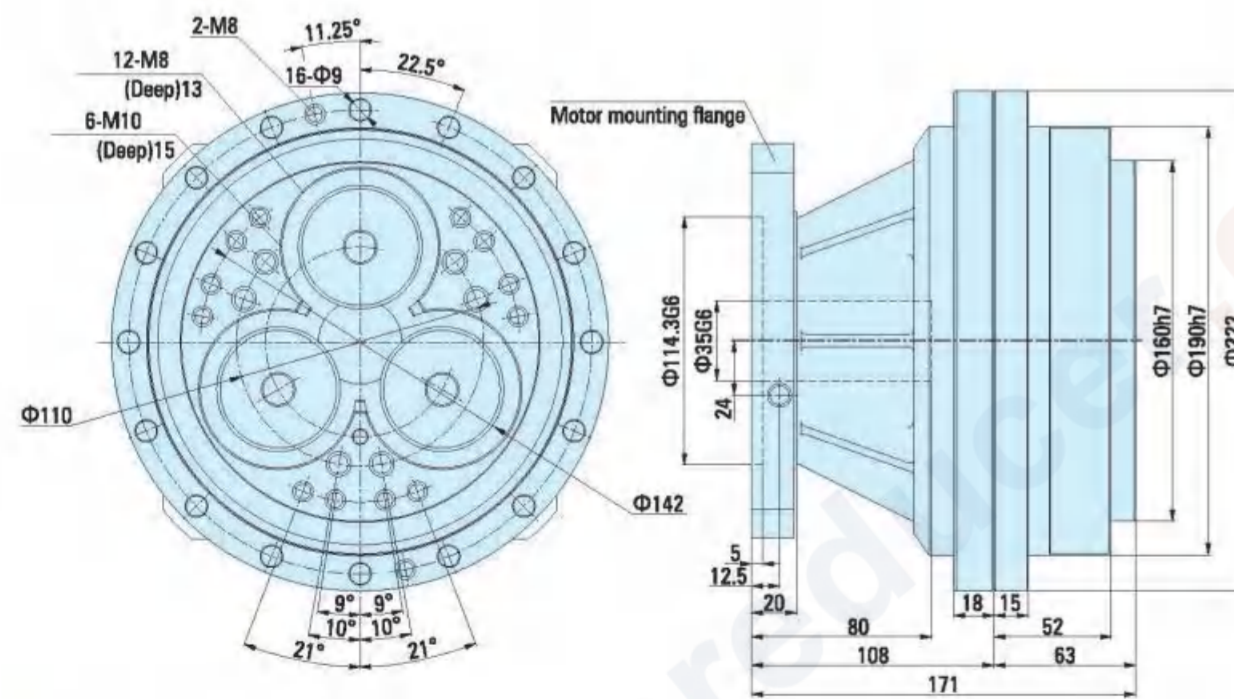

#### Input

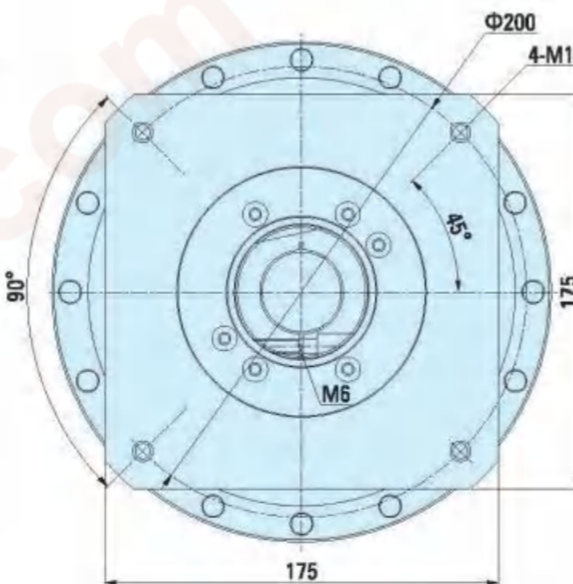

● Note:

1. This figure applies to the motor shaft:  $\leq 35 \times 80L$ ; motor shaft lock use locker.
2. Motor mounting flange according to motor model.

## RV-110EM-(35 Shaft)

### Overall Dimension Drawing



#### Output

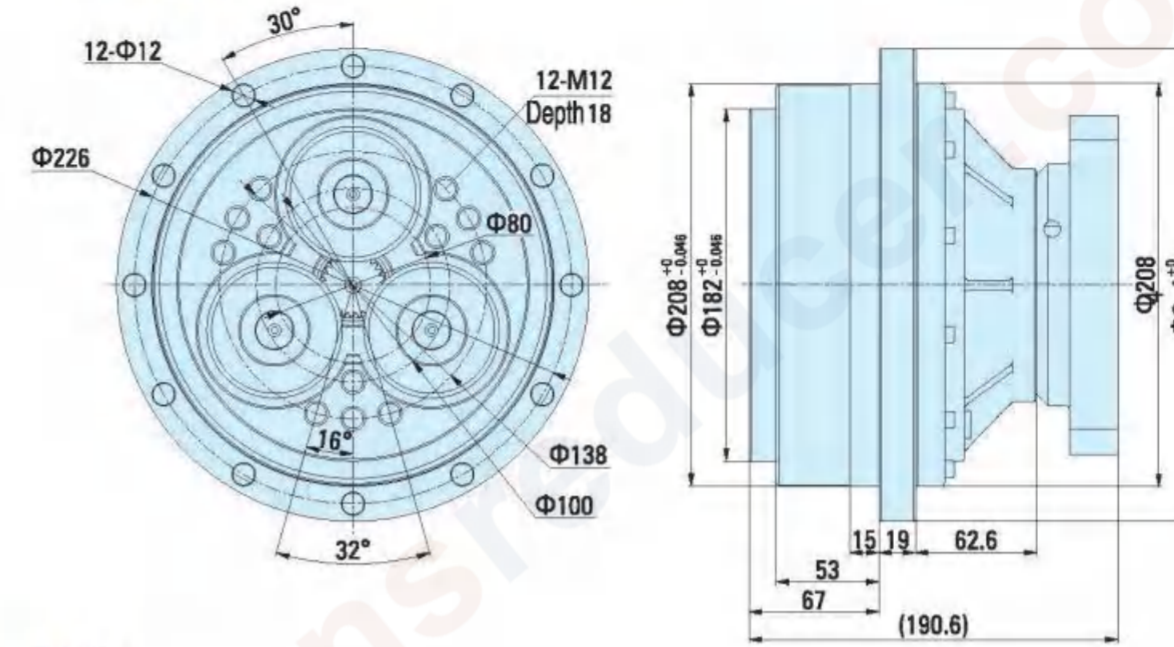

#### Input

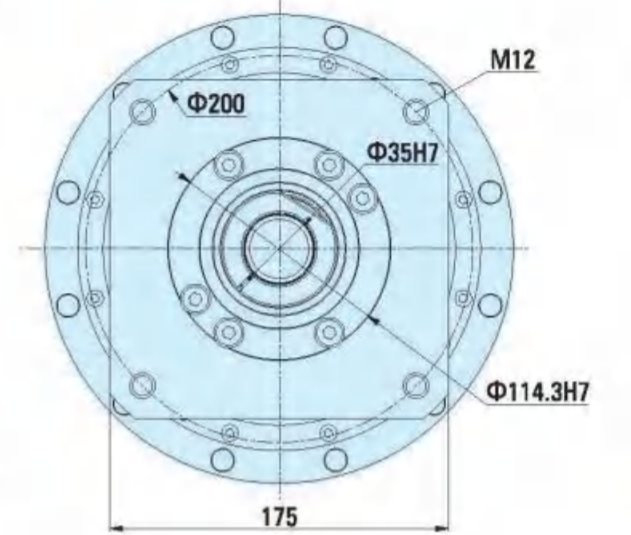

● Note:

1. This figure applies to the motor shaft:  $\leq 35 \times 70L$ ; Motor shaft is locked by locker.
2. Speed reduction ratio: (81, 111, 161): 1 (shaft output).
3. Lubricants: VIGO GREASE RE0 or RE-00 (MOLYWHITE).
4. Rated output torque: 1100N.m (output speed: 15R/Min).
5. The motor mounting flange is supplied according to the motor type.
6. The output terminal must be sealed, please pay attention to the seal and concentricity position during the installation.

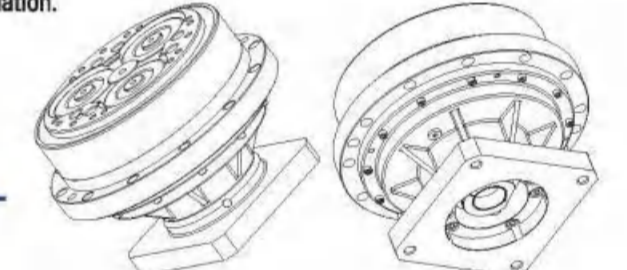

## RV-160EM-(35 Shaft)

### Overall Dimension Drawing

#### Output

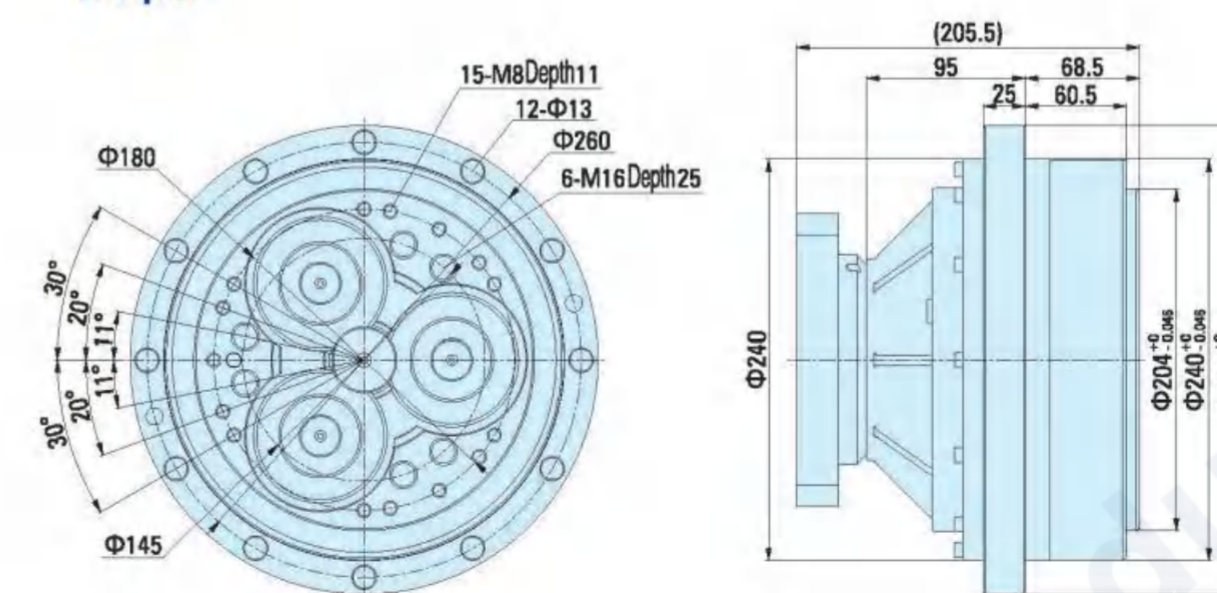

#### Input

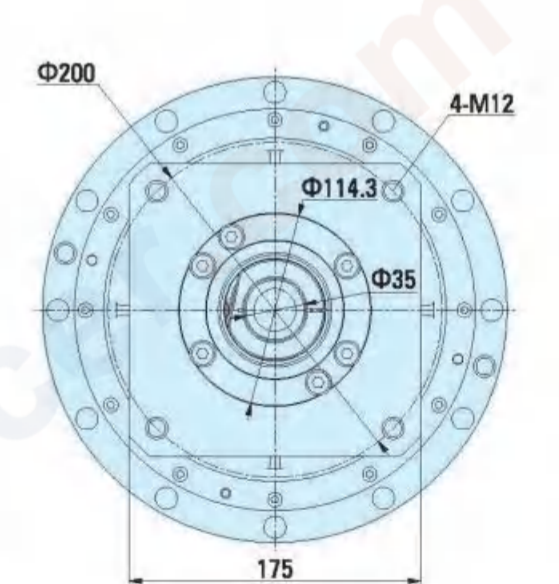

● 说明 Note:

1. This figure applies to the motor shaft:  $\leq 35 \times 70L$ ; Motor shaft is locked by locker.
2. Speed reduction ratio: (81, 129, 171): 1 (shaft output).
3. Lubricants: VIGO GREASE RE0 or RE-00 (MOLYWHITE).
4. Rated output torque: 1570N.m (output speed: 15R/Min).
5. The motor mounting flange is supplied according to the motor type.
6. The output terminal must be sealed, please pay attention to the seal and concentricity position during the installation.



## RV-320EM-(35 Shaft)

### Overall Dimension Drawing

Output

Input

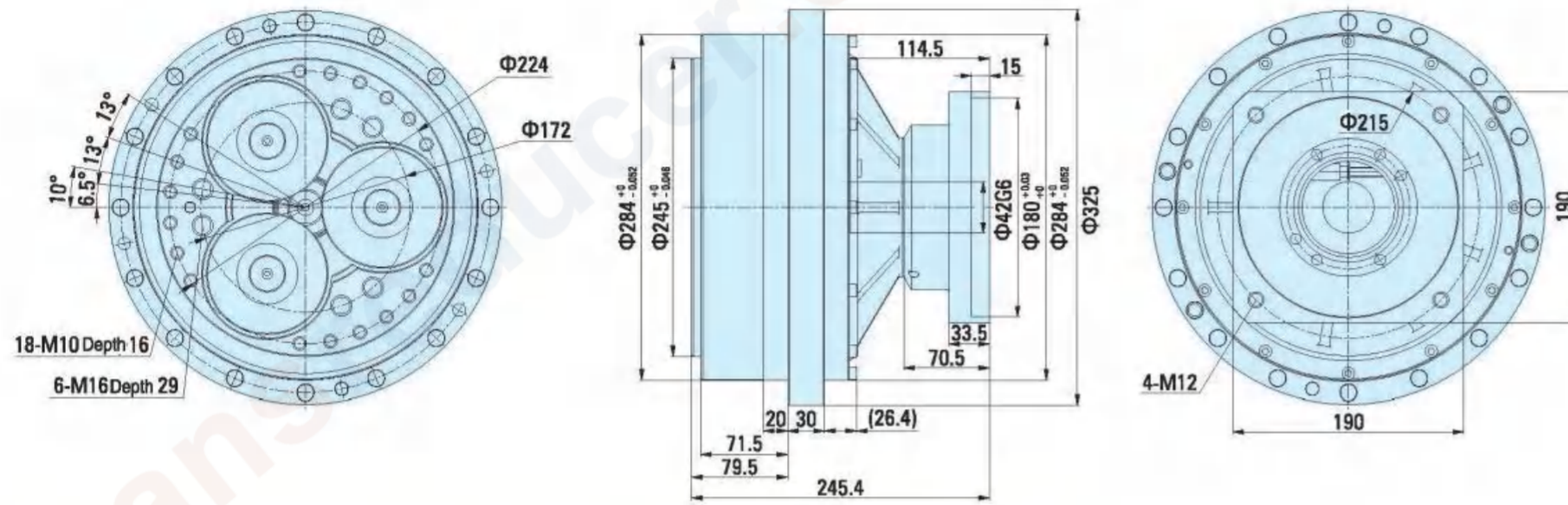

## RV-EM Application example

■ Glass substrate, wafer rotary shaft

■ Connecting axis of the palletizing robot

■ AGV drive and control axis

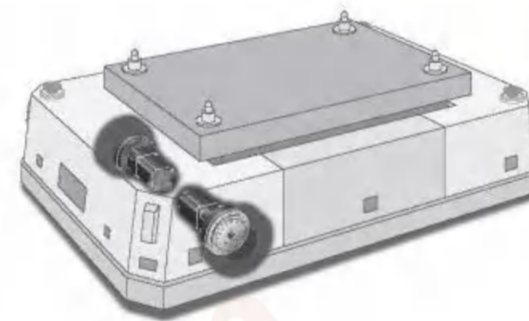
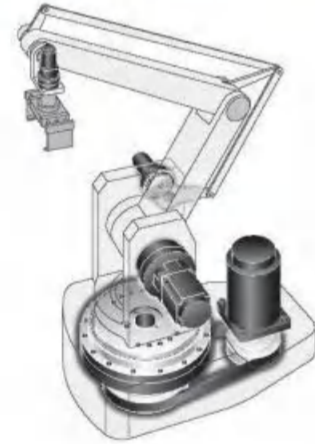

### Maintenance

- The standard replacement time for lubricant is 20,000 hours. However, when operation involves a gearbox surface temperature above 40° C, the state of degradation of the lubricant should be checked in advance of that and the lubricant replaced earlier as necessary.

### Temperature of gearbox

- When using the gearbox under heavy load and at a high duty ratio, it may overheat and the surface temperature may exceed the allowable temperature. Be aware of conditions so that the surface temperature of the gearbox does not exceed 60° C while it is in operation. There is a possibility of damage to the product if the surface temperature exceeds 60° C.

### Output rotary angle of gearbox

- When the range of the rotary angle is small (10 degrees or less), the service life of the gearbox may be reduced due to poor lubrication or the internal parts being subject to a concentrated load.  
Note: Contact us in case the rotary angle is 10 degrees or less.

## RV-CM Series model Indication

- When placing an order or making an inquiry, please use the following codes to specify the appropriate model.

RV - 80 CM - 36.75 - A - B - Motor

Model code	Frame number	Series code	Ratio code	Center gear code	Output shaft clamp code	Motor
RV	10	CM Input matching Motor flange	27	A: Standard gear A Z: No gear 76.3, 100.2 124.7, 151.6 214.3, 264.6	B: Bolt-clamping output shaft type T: Through-bolt clamping output shaft type	Motor
	27		36.57			
	50		32.54			
	100	CK	36.75			
	200		34.86			
	320	CW	35.61			
	500		37.34			

### General equipment

Need bearings + supplying platform

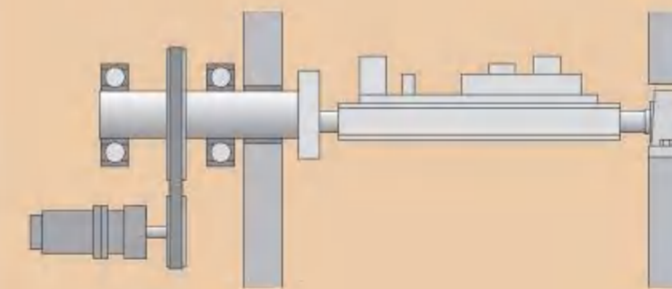

Large number of components, assembly and adjustment takes lots of time and efforts

### RV-CM series

Bearings with large capacity inside

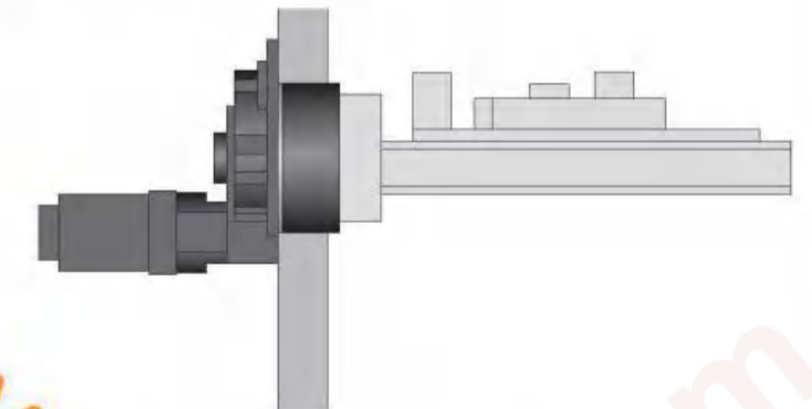

Less components, and less time of assembly and designing take

### General equipment

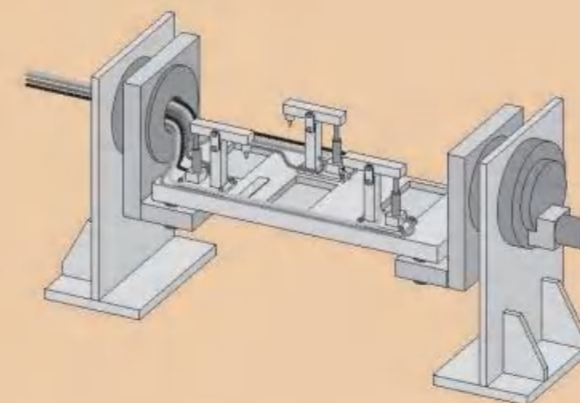

Cable handling is troublesome

### RV-CM series

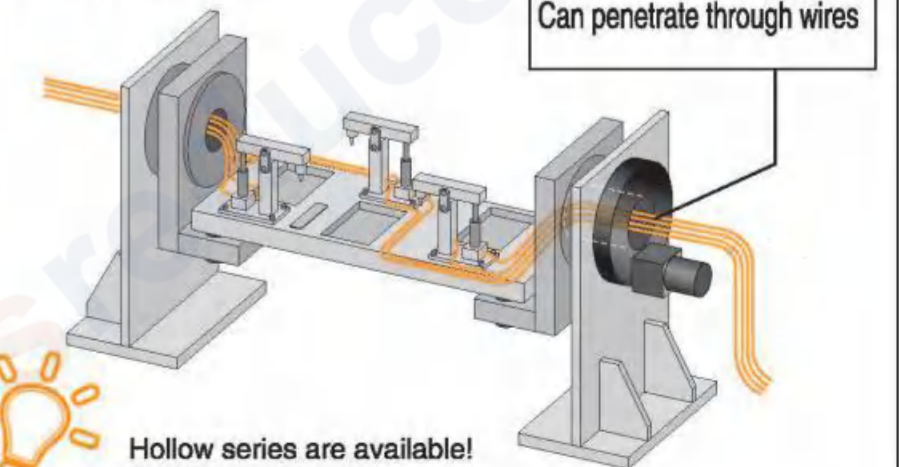

Hollow series are available!  
Can improve layout!

# RV-C series Rating Table

Type	Ratio code	Output speed (rpm)		Output torque (Nm) / Input capacity (kW)									
		R Speed ratio		5	10	15	20	25	30	40	50	60	
		Shaft rotation	Case rotation										
RV-10CM	81, 108	27	26	136	111	98	90	84	80	73	68	65	
	153, 189			0.09	0.16	0.21	0.25	0.29	0.34	0.41	0.47	0.54	
	243												
RV-27CM	79, 103	1,390/38	1352/38	368	299	265	243	227	215	197	184	174	
	157, 177			0.26	0.42	0.55	0.68	0.79	0.90	1.10	1.29	1.46	
	231.5												
RV-50CM	80, 107	1,985/61	1924/61	681	554	490	450	420	398	366	341		
	151, 177			0.48	0.77	1.03	1.26	1.47	1.67	2.04	2.38		
	234												
RV-100CM	76.3, 100.2	36.75	35.75	1,362	1,107	980	899	841	796	730			
	124.7, 151.6			0.95	1.55	2.05	2.51	2.94	3.33	4.08			
	214.3, 264.6												
RV-200CM	34.86	1,499/43	1456/43	2,724	2,215	1,960	1,803	1,686	1,597				
				1.90	3.09	4.11	5.04	5.88	6.69				
RV-320CM	35.61	2,778/78	2700/78	4,361	3,538	3,136	2,881	2,690					
				3.04	4.94	6.57	8.05	9.41					
RV-500CM	37.34	3,099/83	3016/83	6,811	5,537	4,900	4,498						
				4.75	7.73	10.26	12.56						

Note: 1. The allowable output speed will differ depending upon the duty ratio, load, and ambient temperature. Contact us regarding use above the allowable output speed N<sub>s1</sub>.

2. The input capacity (kW) is calculated according to the following calculation formula:

$$\text{Input capacity (kW)} = \frac{2\pi \cdot N \cdot T}{60 \cdot \frac{\eta}{100} \cdot 10^3}$$

N: Output speed (rpm)  
T: Output torque (Nm)  
η = 75: Reduction gear efficiency (%)

Note: The input capacity is a reference value.

3. When the reduction gear is used at low temperatures, there will be a larger no-load running torque. Note this characteristic when selecting a motor. (Refer to "Low temperature characteristic" on page 93)

T <sub>0</sub>	N <sub>0</sub>	K	T <sub>s1</sub>	T <sub>s2</sub>	N <sub>s0</sub>	Backlash	Lost motion MAX.	transmission error MAX.	Startup efficiency (Typical value)	M <sub>01</sub>	M <sub>02</sub>	W <sub>r</sub>	I	I (= $\frac{GD^2}{4}$ ) Inertia of center gear	Weight
(Nm)	(rpm)	(h)	(Nm)	(Nm)	(r/min)	(arcsec)	(arcmin)	(arcsec)	(%)	(Nm)	(Nm)	(N)	(kgm <sup>2</sup> )	(kgm <sup>2</sup> )	(kg)
98	15	6,000	245	490	80	1.0	1.0	70	75	686	1,372	5,755	1.38×10 <sup>-5</sup>	0.678×10 <sup>-3</sup>	4.6
264.6	15	6,000	662	1,323	60	1.0	1.0	70	80	980	1,960	6,520	0.550×10 <sup>-4</sup>	0.563×10 <sup>-3</sup>	8.5
490	15	6,000	1,225	Bolt clamping 2,450 Through-bolt clamping 1,960	50	1.0	1.0	60	75	1,764	3,528	9,428	1.82×10 <sup>-4</sup>	0.363×10 <sup>-2</sup>	14.6
980	15	6,000	2,450	Bolt clamping 4,900 Through-bolt clamping 3,430	40	1.0	1.0	50	80	2,450	4,900	11,802	0.475×10 <sup>-3</sup>	0.953×10 <sup>-2</sup>	19.5
1,960	15	6,000	4,900	Bolt clamping 9,800 Through-bolt clamping 7,350	30	1.0	1.0	50	80	8,820	17,640	31,455	1.39×10 <sup>-3</sup>	1.94×10 <sup>-2</sup>	55.6
3,136	15	6,000	7,840		25	1.0	1.0	50	85	20,580	39,200	57,087	0.518×10 <sup>-2</sup>	0.405×10 <sup>-1</sup>	79.5
4,900	15	6,000	12,250		20	1.0	1.0	50	80	34,300	78,400	82,970	0.996×10 <sup>-2</sup>	1.014×10 <sup>-1</sup>	154

Note:

4. The allowable moment will differ depending on the thrust load. Check the allowable moment diagram (p. 91).

5. The inertia moment value is for the reduction gear. It does not include the inertia moment for the input gear.

6. For the moment rigidity and torsional rigidity, refer to the calculation of tilt angle and the torsion angle (p. 99).

7. The rated torque is the value that produces the rated service life based on operation at the rated output speed; it does not indicate the maximum load. Refer to the "Glossary" (p.81) and the "Product selection flowchart" (p.82).

8. Contact us regarding speed ratios other than those listed above.

9. The specifications above are based on Nabtesco evaluation methods; this product should only be used after confirming that it is appropriate for the operating conditions of your system.

10. When radial load b is applied within dimension b, use the reduction gear within the allowable radial load.

11. \*1 The R=153 for the RV-80E is only for the bolt-clamping output shaft type (page 20, 21).

## RV-10CM-(14 shaft)

### Overall Dimension Drawing Output

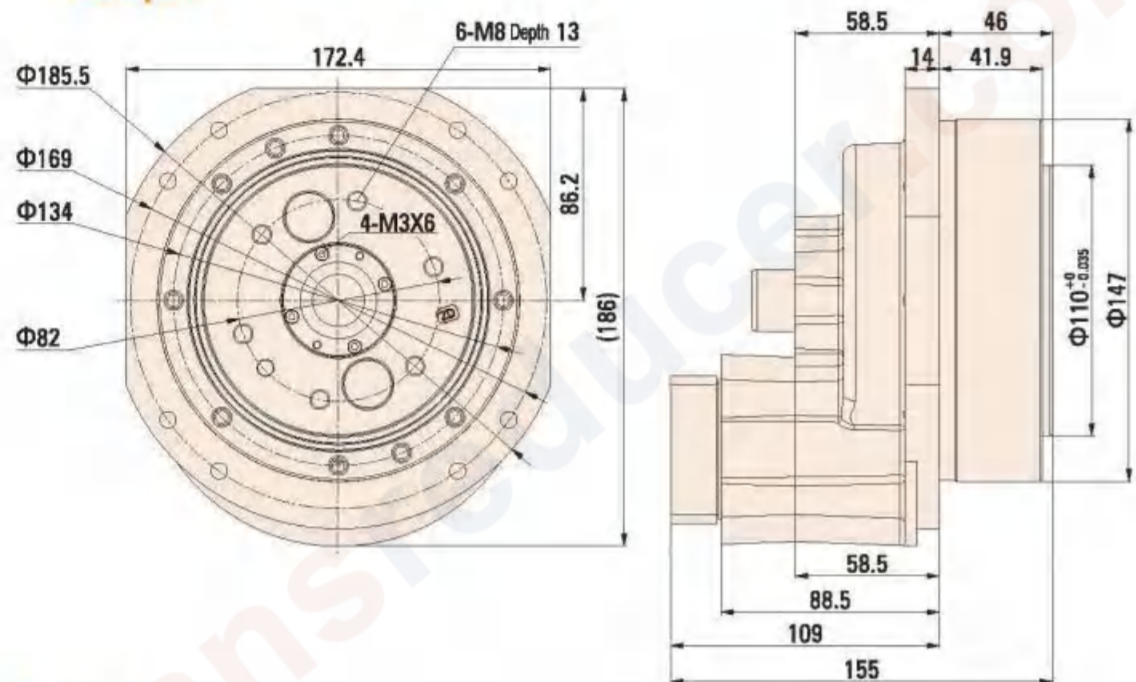

### Input

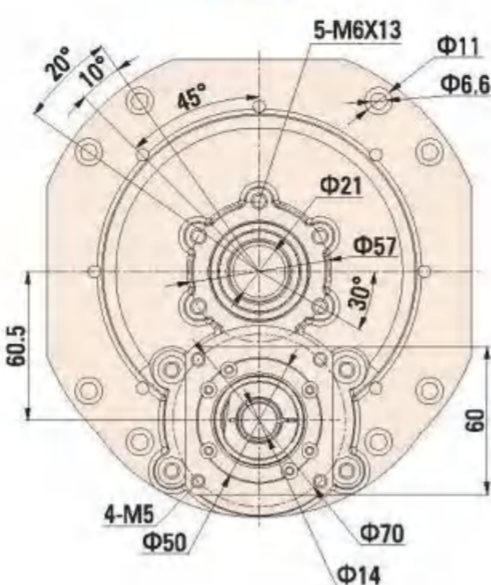

- Note:**
1. This figure applies to the motor shaft:  $\leq 14 \times 30L$ ; Motor shaft is locked by locker.
  2. Speed reduction ratio: (81, 108, 153, 189, 243): 1 (shaft output).
  3. Lubricants: VIGO GREASE RE0 or RE-00 (MOLYWHITE).
  4. Rated output torque: 98N.m (output speed: 15R/Min).
  5. The motor mounting flange is supplied according to the motor type.

## RV-27CM-(19 shaft)

### Overall Dimension Drawing Output

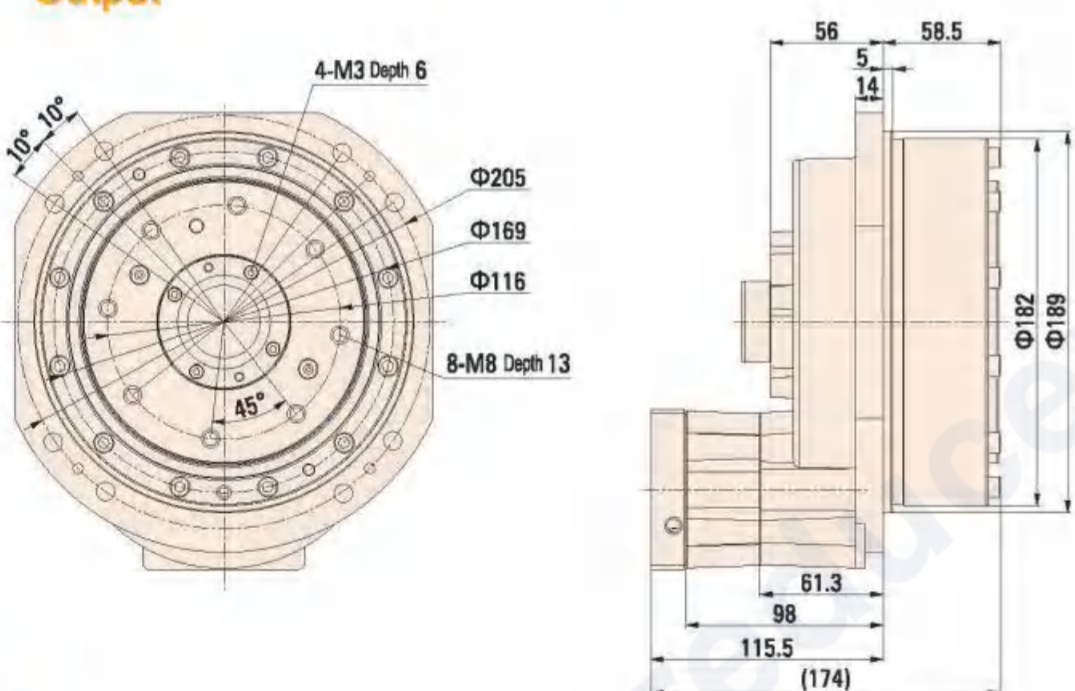
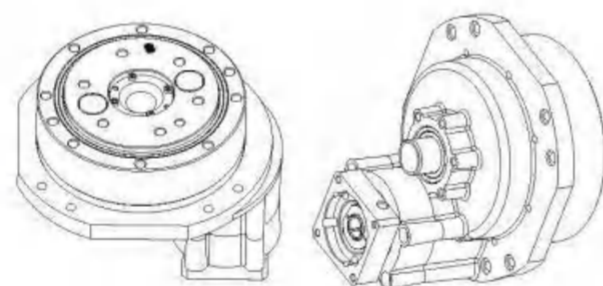

### Input

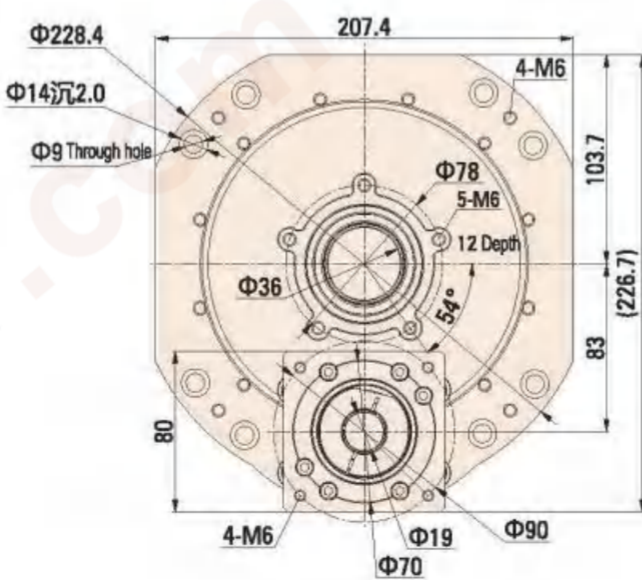

- Note:**
1. This figure applies to the motor shaft:  $\leq 19 \times 35L$ ; Motor shaft is locked by locker
  2. Speed reduction ratio: (79, 99, 140, 189, 231.6): 1 (shaft output).
  3. Lubricants: VIGO GREASE RE0 or RE-00 (MOLYWHITE).
  4. Rated output torque: 270N.m (output speed: 15R/Min).
  5. The motor mounting flange is supplied according to the motor type.

## RV-50CM-(24 shaft)

### Overall Dimension Drawing Output

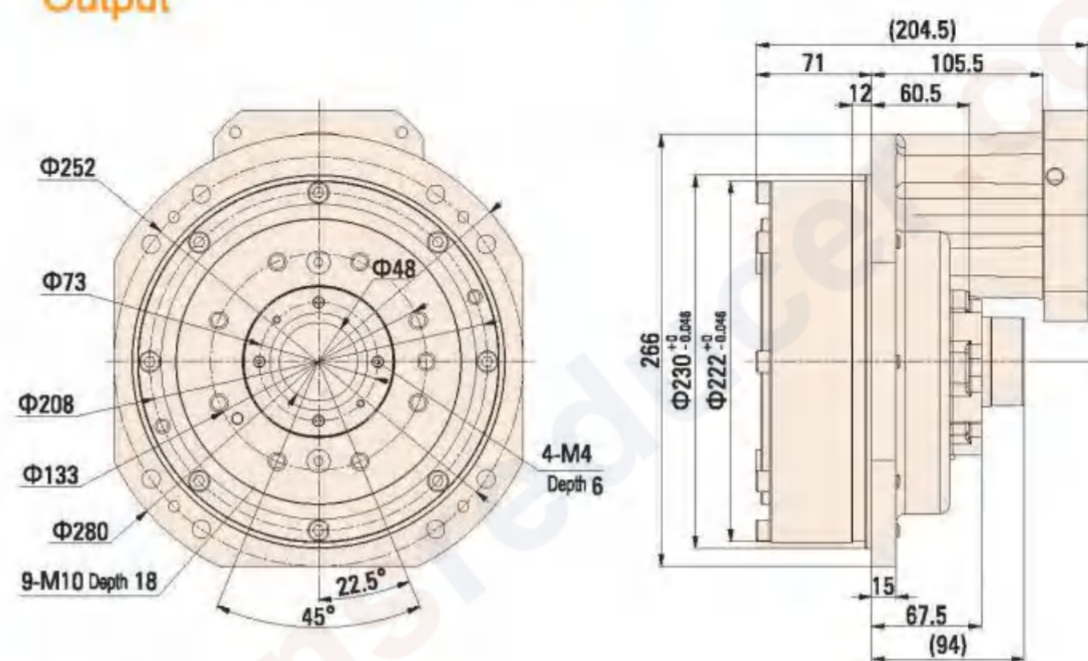

### Input

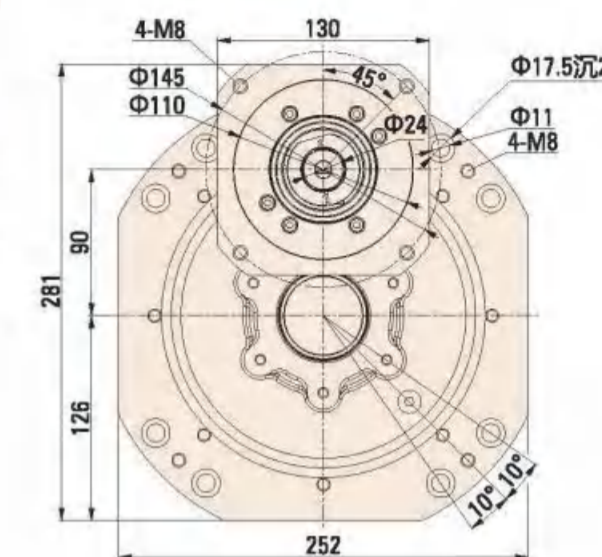

- Note:**
1. This figure applies to the motor shaft:  $\leq 24 \times 55L$ ; Motor shaft is locked by locker.
  2. Speed reduction ratio: (49, 107, 125, 150, 193, 234): 1 (shaft output).
  3. Lubricants: VIGO GREASE RE0 or RE-00 (MOLYWHITE).
  4. Rated output torque: 498N.m (output speed: 15R/Min).
  5. The motor mounting flange is supplied according to the motor type.

## RV-100CM-(24 shaft)

### Overall Dimension Drawing Output

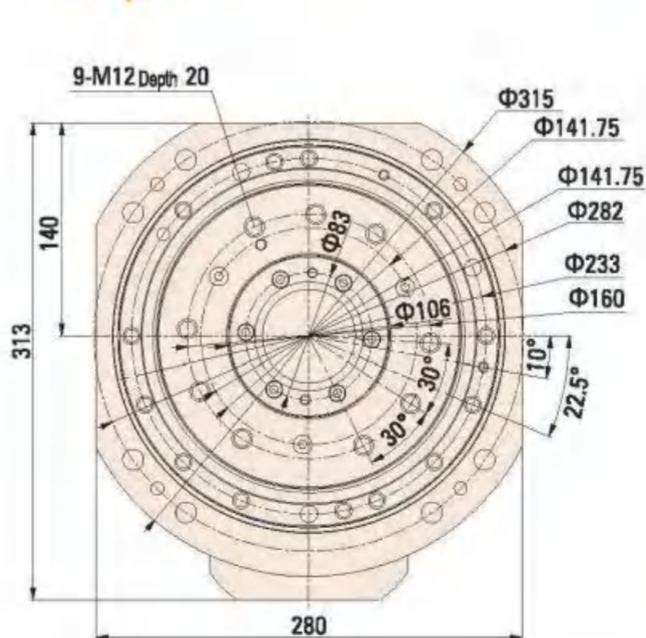
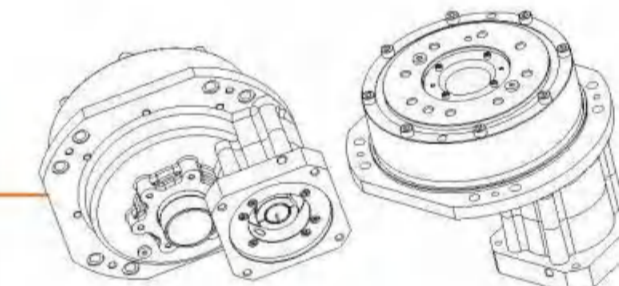

### Input

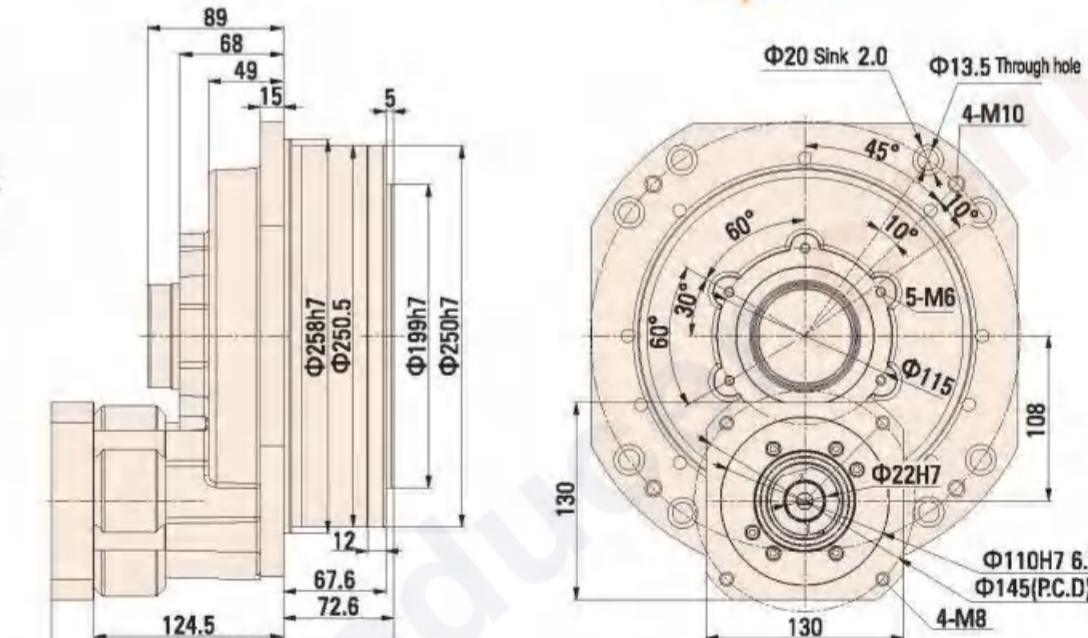

- Note:**
1. This figure applies to motor shaft:  $= 22 \times 55L$ ; motor shaft is locked with lock;
  2. Reducer speed ratio: (76.3, 100.2, 124.7, 151.6, 214.3, 264.6): 1 (shaft output);
  3. Grease: VIGO GREASE RE0 or RE-00 (MOLYWHITE);
  4. Rated output torque: 980N.m (output speed: 15R / Min);
  5. Motor mounting flange according to the motor model;

## RV-10CK

### Overall Dimension Drawing Output

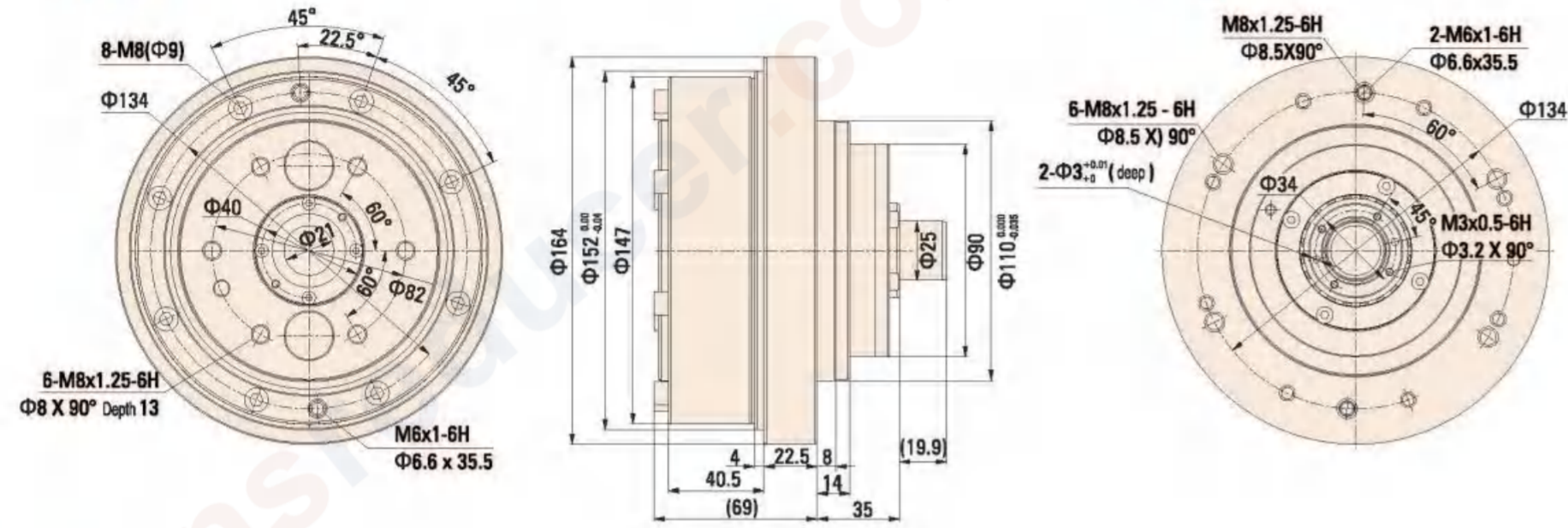

**Note:**

1. This picture shows the hollow 10CBX reducer, the input end with timing pulley;
2. Reducer speed ratio: 27:1;
3. Grease: VIGO GREASE RE0 or RE-00 (MOLYWHITE);
4. Rated output torque: 98N.m (output speed: 15R / Min);
5. The installation flanges shall be specially designed and manufactured to ensure the center distance and the relevant requirements of the PRCs;
6. Seal to be installed, pay attention to concentricity positioning.

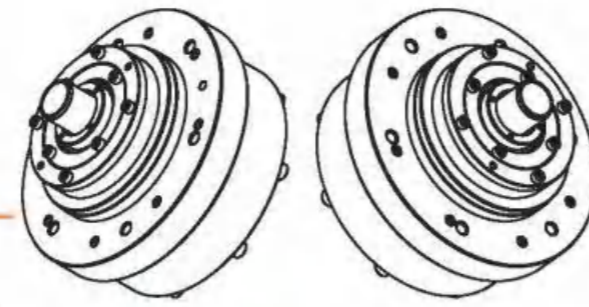

Input

## RV-50CK

### Overall Dimension Drawing Output

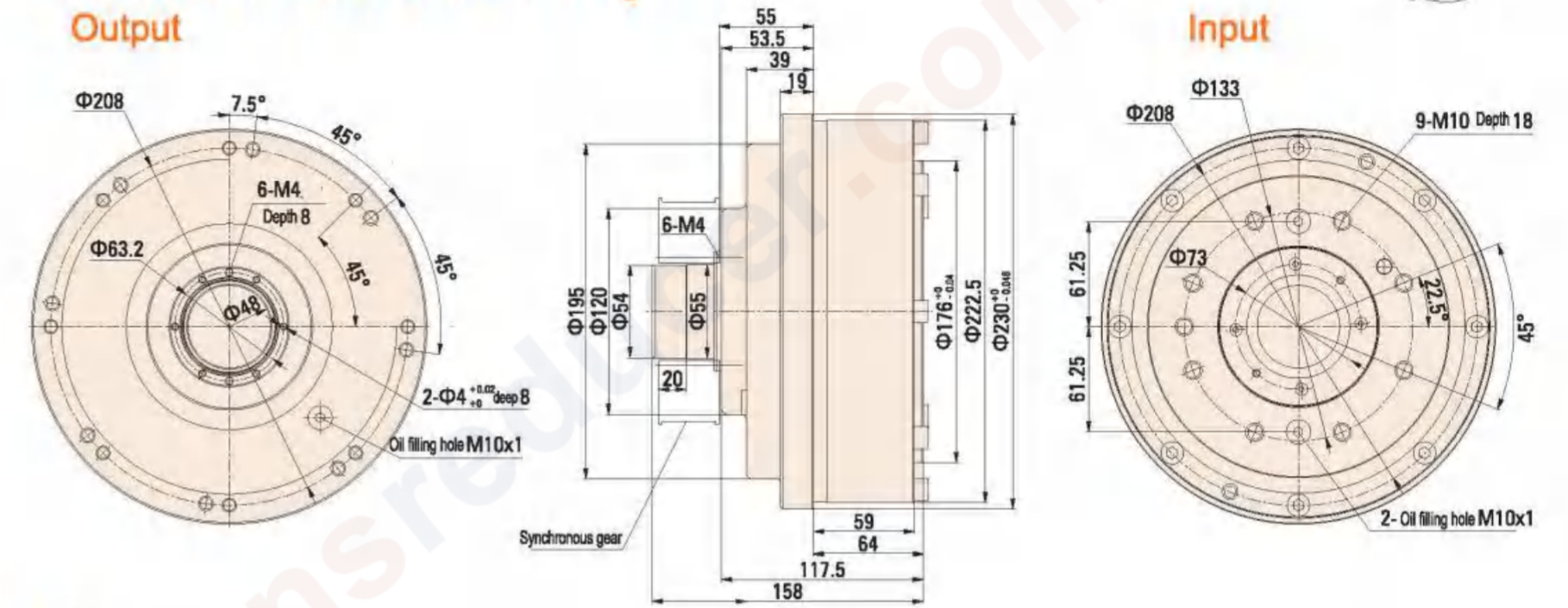

**Note:**

1. The figure applies with timing pulley;
2. Reducer speed ratio: 32.54:1 ;
3. Grease: VIGO GREASE RE0 or RE-00 (MOLYWHITE);
4. Rated output torque: 498N.m (output speed: 15R / Min);
5. System reduction ratio: 32.54 multiplied by the speed ratio belt;

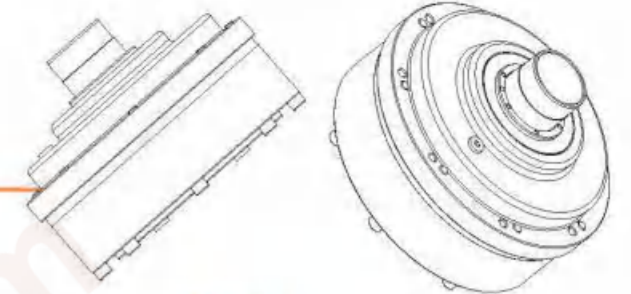

Input

## RV-27CK

### Overall Dimension Drawing Output

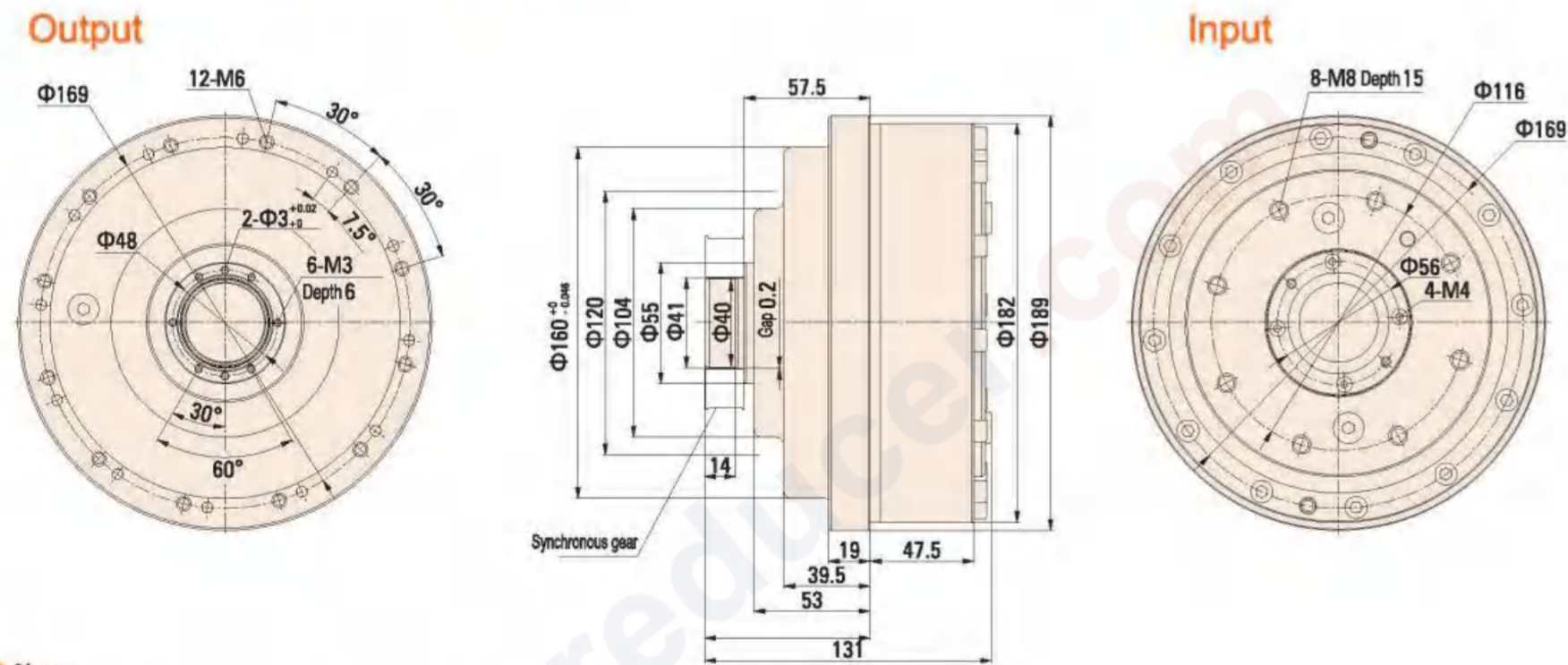

**Note:**

1. This picture shows the hollow 10CBX reducer, the input end with timing pulley;
2. Reducer speed ratio: 27:1;
3. Grease: VIGO GREASE RE0 or RE-00 (MOLYWHITE);
4. Rated output torque: 98N.m (output speed: 15R / Min);
5. The installation flanges shall be specially designed and manufactured to ensure the center distance and the relevant requirements of the PRCs;
6. Seal to be installed, pay attention to concentricity positioning.

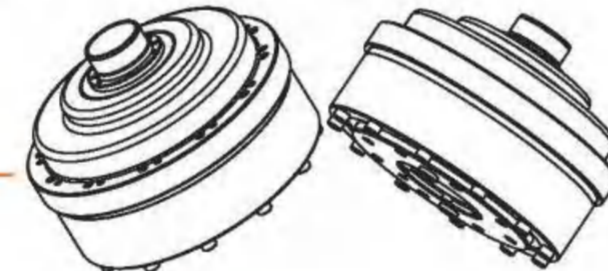

Input

## RV-100CK

### Overall Dimension Drawing Output

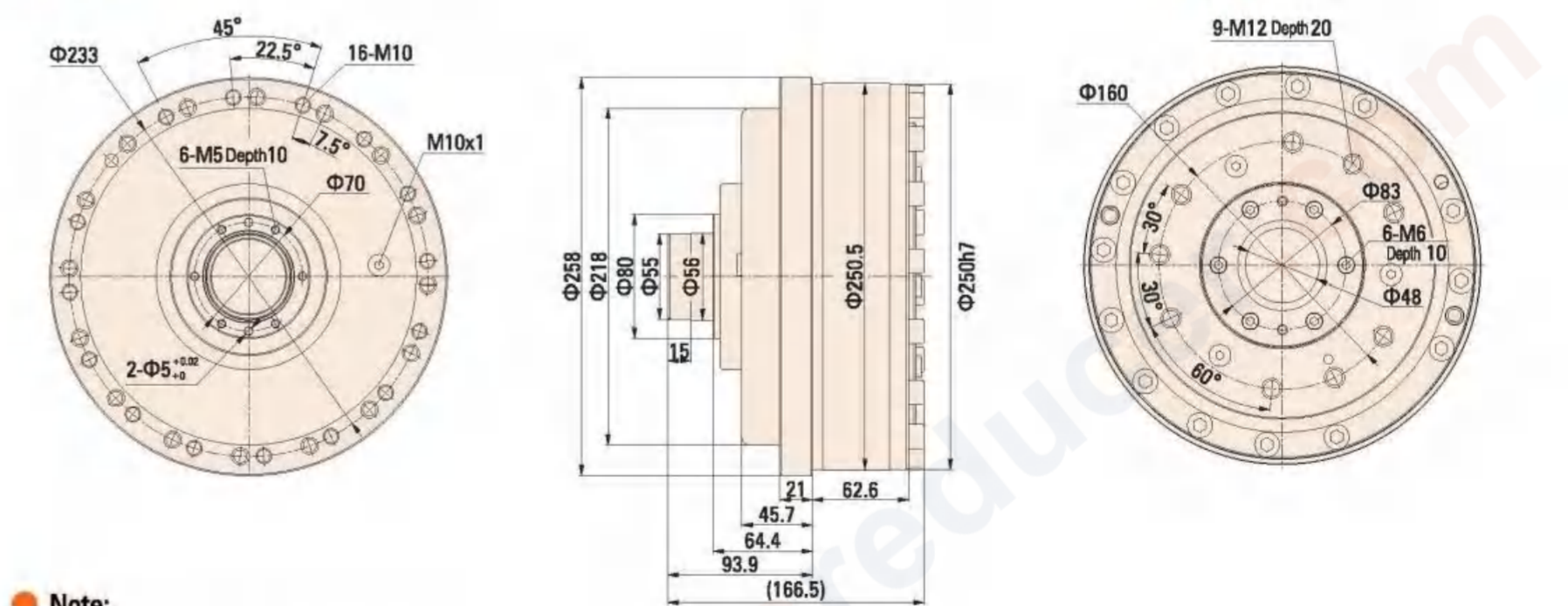

**Note:**

1. The figure applies with timing pulley;
2. Reducer speed ratio: 36.75:1 ;
3. Grease: VIGO GREASE RE0 or RE-00 (MOLYWHITE);
4. Rated output torque: 980N.m (output speed: 15R / Min);
5. System reduction ratio: 36.75 multiplied by the speed ratio belt;

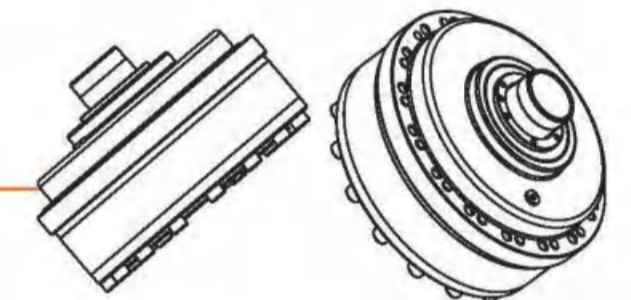

Input

## RV-10CW

### Overall Dimension Drawing

#### Output

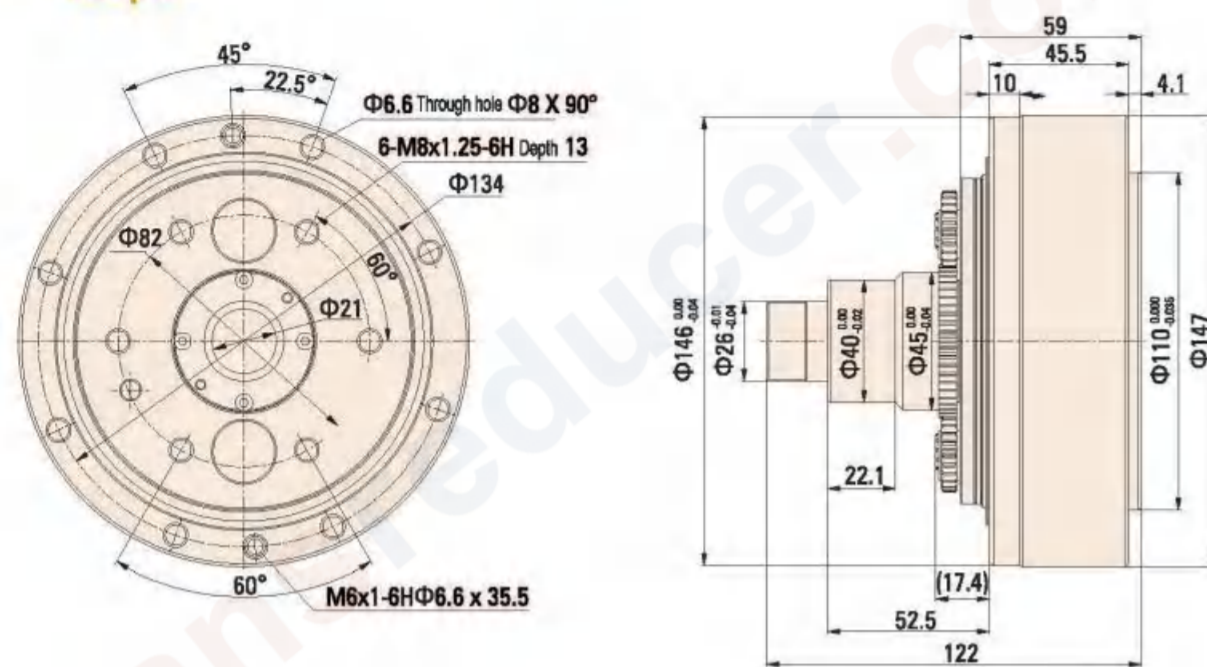

#### Input

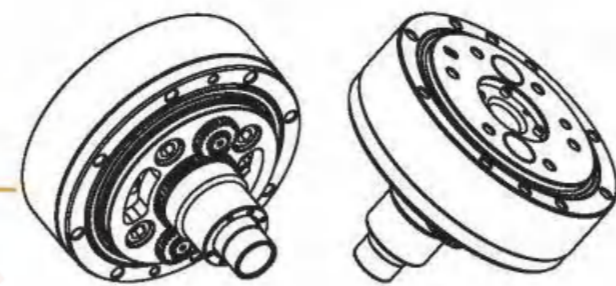
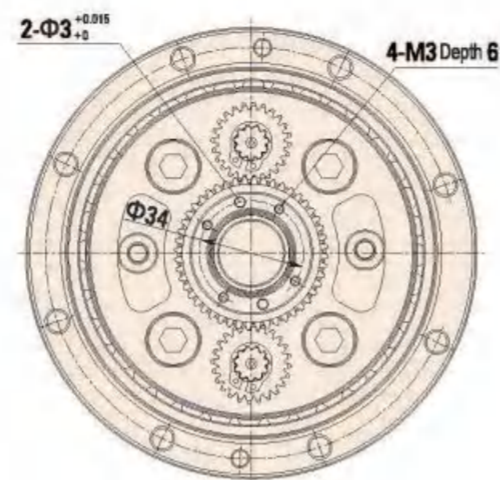

#### Note:

1. Reducer single reduction ratio:  $i = 27$  (shaft output), reducer overall weight: 8.2kg;
2. Graphic center input type for synchronous belt drive, the customer design assembly interface;
3. Reducer rated output torque of 98Nm (output speed 15RPM, input motor power 200W);
4. When using gear reducer add grease, grease recommendations: RE0, RE00. And make the appropriate sealing measures and oil drain device;

## RV-27CW

### Overall Dimension Drawing

#### Output

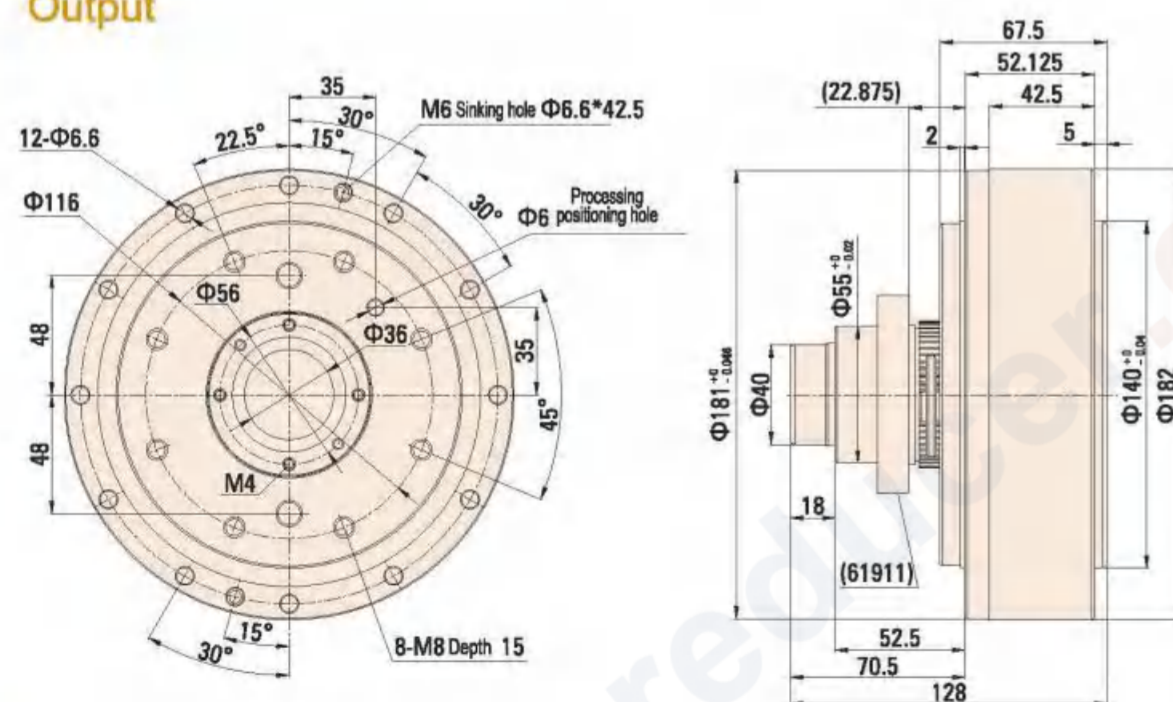

#### Input

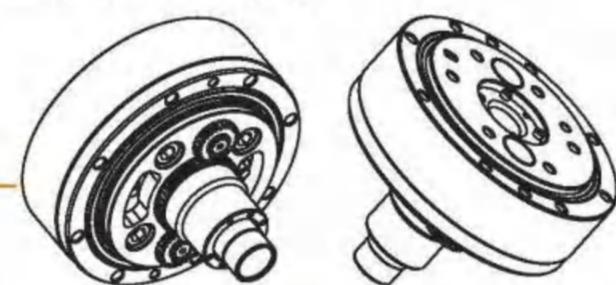
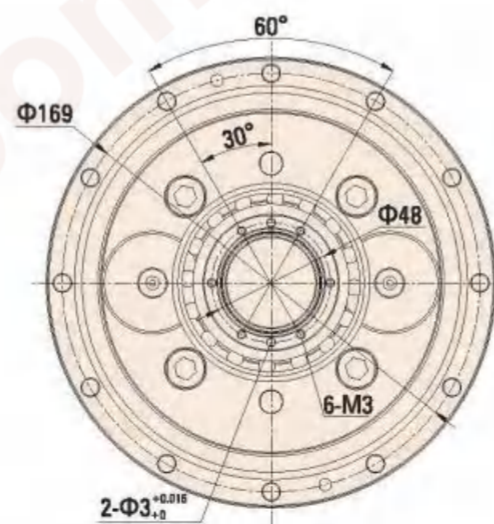

#### Note:

1. Reducer single reduction ratio:  $i = 36.57$  (shaft output), reducer overall weight: 9.5kg;
2. Reducer rated output torque of 270Nm (output speed 15RPM, input motor power 550W);
3. Reducer is not injected lubricating grease, grease recommended RE0;
4. Reducer to be used when necessary to make the appropriate sealing measures, plus drain device;

## RV-50CW

### Overall Dimension Drawing

#### Output

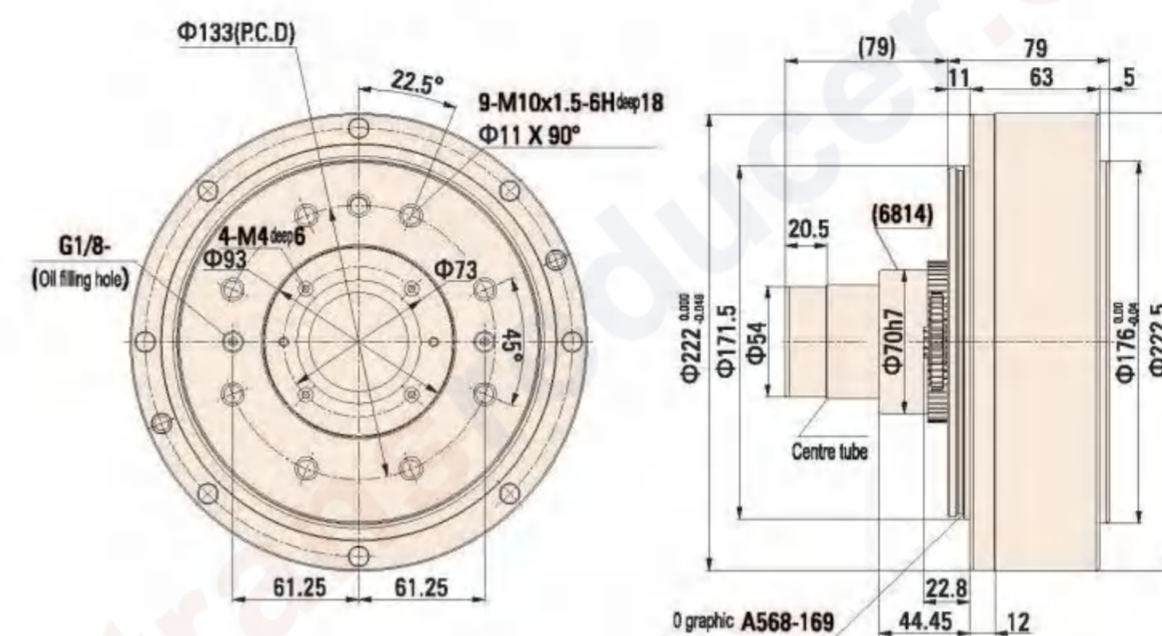

#### Input

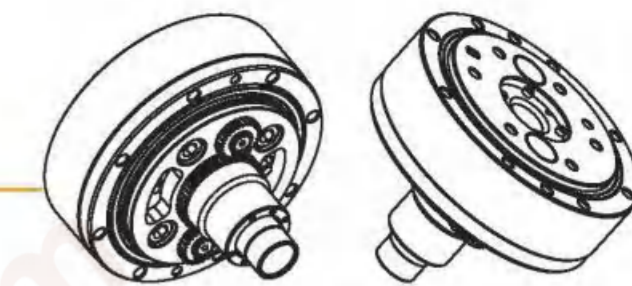
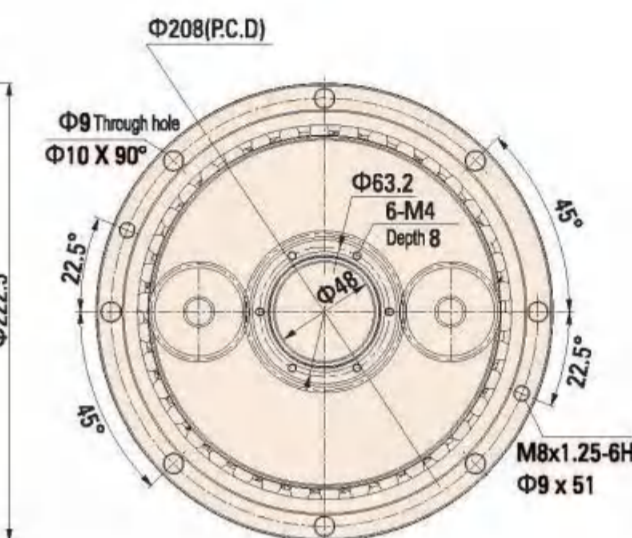

## RV-100CW

### Overall Dimension Drawing

#### Output

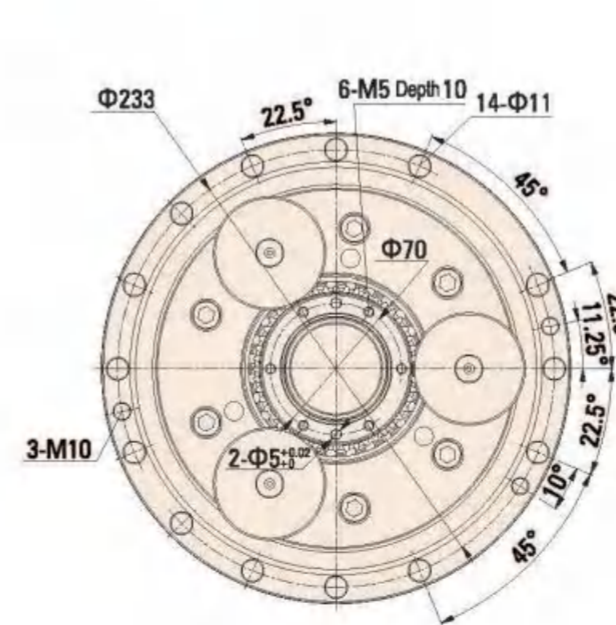

#### Input

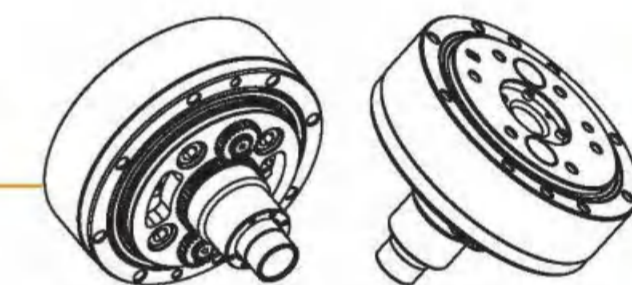
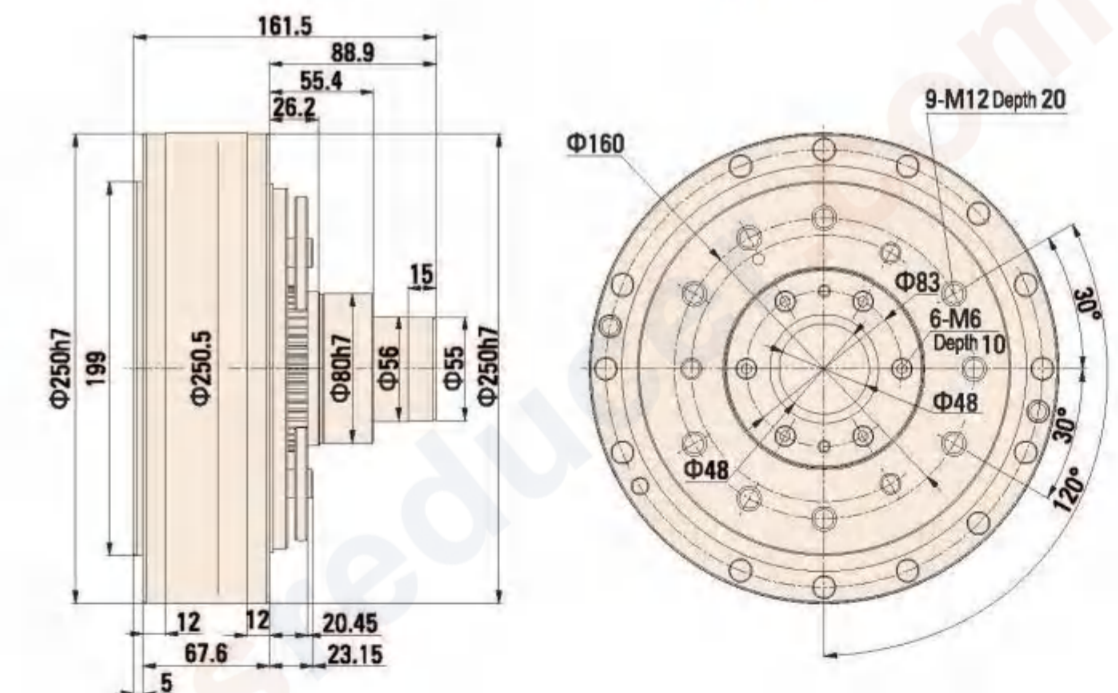

## Technical data Calculation tilt angle and torsion angle

### Calculation tilt angle

When a load moment occurs with an external load applied, the output shaft will tilt in proportion to the load moment (If  $l_3$  is larger than b.)

The moment rigidity indicates the rigidity of the main bearing, and it is represented by the load moment value required for tilting the main bearing by 1 arc.min.

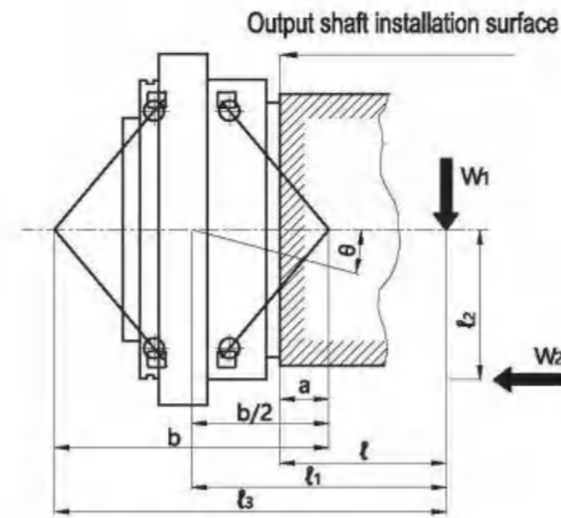

$$\theta = \frac{W_1 l_1 + W_2 l_2}{M_t \times 10^3}$$

$\theta$  : Tilt angle of the output shaft (arc.min.)  
 $M_t$  : Moment rigidity (Nm/arc.min.)  
 $W_1, W_2$  : Load (N)  
 $l_1, l_2$  : Distance to the point of load application (mm)  
 $l_1$  :  $l + \frac{b}{2} - a$   
 $l$  : Distance from the output shaft installation surface to the point of load application (mm)

#### E Series

Model	Moment rigidity (Nm/arc.min.) $\times 3$	Size (mm)	
		a	b
RV-6E	117	17.6	91.6
RV-20E	372	20.1	113.3
RV-40E	931	29.6	143.7
RV-80E $\times 1$	1,176	33.4	166.0
RV-80E $\times 2$	1,176	37.4	166.0
RV-110E	1,470	32.2	176.6
RV-160E	2,940	47.8	210.9
RV-320E	4,900	56.4	251.4
RV-450E	7,448	69.0	292.7

#### C Series

Model	Moment rigidity (Nm/arc.min.) $\times 3$	Size (mm)	
		a	b
RV-10C	421	28.0	119.2
RV-27C	1,068	38.2	150.3
RV-50C	1,960	50.4	187.1
RV-100C	2,813	58.7	207.6
RV-200C	9,800	76.0	280.4
RV-320C	12,740	114.5	360.5
RV-500C	24,500	125	413.4

- \* 1 Bolt mounting output shaft type
- \* 2 Pin/bolt clamping output shaft type
- \* 3 The moment rigidity values are typical values.

### Calculation of torsion angle

Calculate the torsion angle when the torque is applied in a single direction, using an example of RV-160E.

- When the load torque is 30 Nm.....Torsion angle (ST1)
  - When the load torque is 3% or less of the rated torque

$$ST_1 = \frac{30}{47.0} \times \frac{1 \text{ (arc.min.)}}{2} = 0.32 \text{ (arc.min.)}$$

- When the load torque is 1,300 Nm.....Torsion angle (ST2)
  - When the load torque is more than 3% of the rated torque and less than the rated torque

$$ST_2 = \frac{1}{2} + \frac{1,300 - 47.0}{392} = 3.70 \text{ (arc.min.)}$$

Note: The torsion angles that are calculated above are for a single gearbox.

#### E Series

Model	Torsion rigidity (Nm/arc.min.)	Lost motion		Backlash (arc.min.)
		Lost motion (arc.min.)	(Nm) Measured torque	
RV-6E	20	MAX1.5	$\pm 1.76$	MAX1.5
RV-20E	49	MAX1	$\pm 5.00$	MAX1
RV-40E	108		$\pm 12.3$	
RV-80E	196		$\pm 23.5$	
RV-110E	294		$\pm 32.3$	
RV-160E	392		$\pm 47.0$	
RV-320E	980		$\pm 94.0$	
RV-450E	1,176	$\pm 132.0$		

#### C Series

Model	Torsion rigidity (Nm/arc.min.)	Lost motion		Backlash (arc.min.)	
		Lost motion (arc.min.)	(Nm) Measured torque		
RV-10C	47	MAX1	$\pm 2.94$	MAX1	
RV-27C	147		$\pm 7.94$		
RV-50C	255		$\pm 14.7$		
RV-100C	510		$\pm 29.4$		
RV-200C	980		$\pm 58.8$		
RV-320C	1,960		$\pm 94.1$		
RV-500C	3,430		$\pm 147.0$		

## Design points Mounting bolt of gearbox

### Installation of the gearbox and mounting it to the output shaft

When installing the gearbox and mounting it to the output shaft, use hexagon socket head cap screws and tighten to the torque, as specified below, in order to satisfy the momentary maximum allowable torque, which is noted in the rating table.

The use of the Belleville spring washers are recommended to prevent the bolt from loosening and protect the bolt seat surface from flaws.

- Hexagon socket head cap screw

<Bolt tightening torque and tightening force>

Hexagon socket head cap screw Nominal size x pitch(mm)	(Nm) Tightening torque	F (N) Tightening force	Bolt specification
M5 x 0.8	9.01 $\pm$ 0.49	9,310	♦ Hexagon socket head cap screw JIS B 1176: 2006
M6 x 1.0	15.6 $\pm$ 0.78	13,180	
M8 x 1.25	37.2 $\pm$ 1.86	23,960	♦ Strength class JIS B 1051: 2000 12.9
M10 x 1.5	73.5 $\pm$ 3.43	38,080	
M12 x 1.75	129 $\pm$ 6.37	55,100	♦ Thread JIS B 0209: 2001 6g
M16 x 2.0	319 $\pm$ 15.9	103,410	

Note: 1. The tightening torque values listed are for steel or cast iron material.

- If softer material, such as aluminum or stainless, is used, limit the tightening torque. Also take the transmission torque and load moment into consideration.

<Calculation of allowable transmission torque of bolts>

	T	Allowable transmission torque by tightening bolt (Nm)
	F	Bolt tightening force (N)
	D	Bolt mounting P.C.D. (mm)
	$\mu$	Friction factor $\mu=0.15...$ When lubricant remains on the mating face. $\mu=0.20...$ When lubricant is removed from the mating face.
	n	Number of bolts (pcs.)

$$T = F \times \mu \times \frac{D}{2 \times 1,000} \times n$$

- Serrated lock washer for hexagon socket head cap screw

Name: Belleville spring washer (made by Heiwa Hatsujo Industry Co., Ltd.)

Corporation symbol: CDW-H

CDW-L (Only for M5)

Material: S50C to S70C

Hardness: HRC40 to 48

(Unit mm)

Nominal size	ID and OD of Belleville spring washer		t	H
	$\phi d$	$\phi D$		
5	5.25	8.5	0.6	0.85
6	6.4	10	1.0	1.25
8	8.4	13	1.2	1.55
10	10.6	16	1.5	1.9
12	12.6	18	1.8	2.2
16	16.9	24	2.3	2.8

Note: When using any equivalent washer, select it with special care given to its outside diameter.

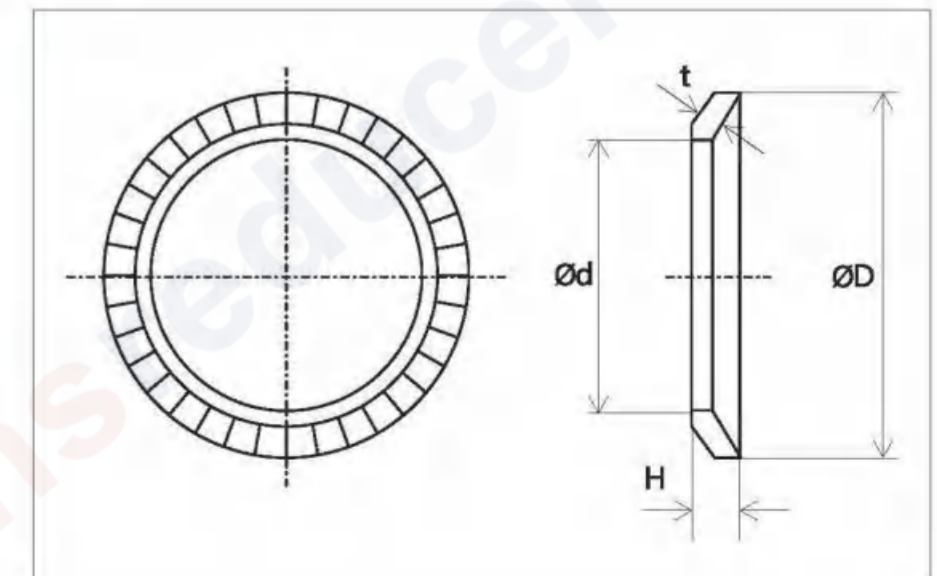

# Design points Input gears

## Pass-through and capacity of input gear

The following table shows which ratios can and can not allow the input gear to pass through.

**E Series** (Unit mm)

Model	Hole dia		Depth	Speed ratio adequate for shaft passage				Speed ratio inadequate for shaft passage	
	d1	d2		Shaft revolution		Case revolution		Shaft revolution	Case revolution
RV-6E	19	21	18	53.5, 59, 79, 103				52.5, 58, 78, 102	
RV-20E	22	24	18.5	81, 105, 121, 141				80, 104, 120, 140	
RV-40E	27	30	23.5	81, 105, 121, 153				80, 104, 120, 152	
RV-80E	37	40	23	81, 101, 121, 153				80, 100, 120, 152	
RV-110E	39	42	20	81, 111, 127.7, 161, 175.2				80, 110, 126.7, 160, 174.2	
RV-160E	43	47	30	81, 101, 129, 145, 171				* 66 * 65	
RV-320E	47	52	34	81, 101, 118.5, 129, 141, 171, 185				* 66 * 65	
RV-450E	57	62	40	81, 101, 118.5, 129, 155, 171, 192				* 66 * 65	

\* Not described on the rating table. Please consult us if needed.

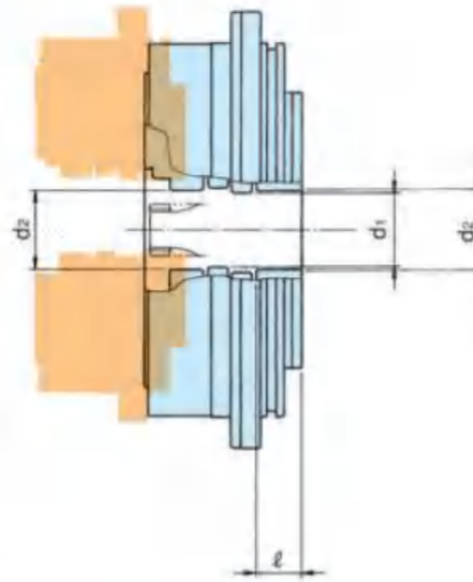

## Speed ratio inadequate for shaft passage

The lower the speed ratio, the larger the outside diameter of the input gear. Therefore, the installation of the input gear through the gearbox is not possible with all ratios. (Refer to "External Dimensions")

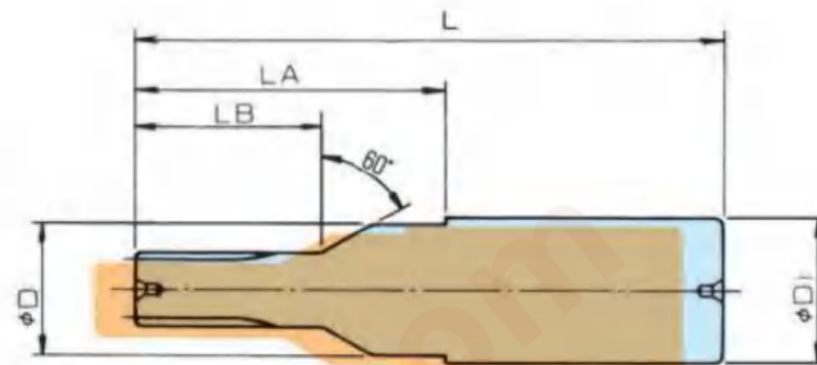
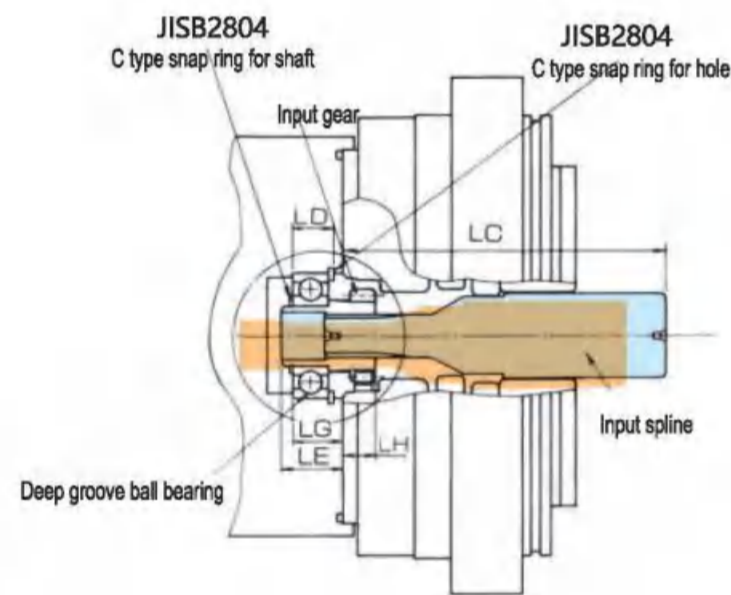

**E Series** (Unit mm)

Series	L	LA	LB	D	D1	LC	LD <sup>+0.1</sup>	LE	LG <sup>±0.1</sup>	LH	Deep groove ball bearing
RV-6E Model	96	60	23	18	28	92	10.3	16	13	7.5	6002
RV-20E, RV-15	95	53	30	21.5	23.5	90	11.7	17	14	9	6003
RV-40E, RV-30	105	58	30	26.5	29.5	103	13.9	19	16	11.5	6004
RV-80E <sup>*1</sup> , RV-60	110	—	35	36	←	109	13.9	15.5	12	16	6005
RV-80E <sup>*2</sup> , RV-60	110	—	35	36	←	105	13.9	19.5	16	12	6005
RV-160E, RV-160	130	—	38	42	←	128	15.1	21	17	16	6006
RV-320E, RV-320	155	—	48	46	←	148	16.1	22	18	20	6007
RV-450E, RV-450	200	—	48	56	←	195	17.6	26	22.5	21	6008

Note: Deep groove ball bearing and C-shaped snap rings are to be provided by the customer.

\*1: Bolt clamping output shaft type \*2: Pin/bolt clamping output shaft type

## Accuracy of center gear and input gear for RV-C series

Poor installation accuracy of center gear and input gear may cause noise and backlash, so design center gear and input gear according to the following accuracy.

\* Attach a bearing to the input gear to accommodate the reaction torque from the center gear.

(Unit mm)

Tolerance of fitting X	Tolerance of concentricity a	Tooth grade of small center gear	Tooth grade of large center gear	Tooth grade of input gear
h6	MAX0.03	JIS 5 class or lower	JIS 4 class or lower	JIS 5 class or lower

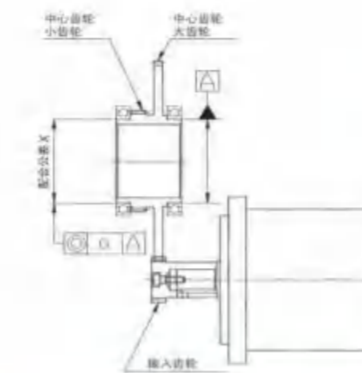

(Unit/mm) Specifications of small center gear tooth

	Backlash between input gear and large center gear	Module	Number of teeth	Addendum modification coefficient
RV-10C	0.035 ~ 0.090	1.0	48	- 0.04
RV-27C	0.040 ~ 0.110	1.0	57	+ 0.2
RV-50C	0.050 ~ 0.130	1.25	61	0
RV-100C	0.060 ~ 0.140	1.75	48	+ 0.3
RV-200C	0.075 ~ 0.180	2.5	43	0
RV-320C		2	78	0
RV-500C		2	83	0

## Standard center gear

The standard center gears for C series are available from 3F. If the standard center gear is needed, please specify when ordering. Refer to the external dimension for installation Specifications of standard large center gears are shown below.

	Module	Number of teeth	Addendum modification coefficient	Base tangent length(mm)	Addendum modification coefficient
RV-10C	2	57	0	39.974 <sup>-0.017</sup> <sub>-0.042</sub>	7
RV-27C	1.25	78	0	32.732 <sup>-0.023</sup> <sub>-0.061</sub>	9
RV-50C	2	78	0	52.371 <sup>-0.023</sup> <sub>-0.061</sub>	9
RV-100C	1.75	112	0	67.323 <sup>-0.028</sup> <sub>-0.066</sub>	13
RV-200C	2	110	0	76.885 <sup>-0.035</sup> <sub>-0.085</sub>	13
RV-320C	2	125	0	89.113 <sup>-0.035</sup> <sub>-0.085</sub>	15
RV-500C	2	150	0	101.622 <sup>-0.035</sup> <sub>-0.085</sub>	17

## Standard input gear specifications

Material	
Heat treatment	Carburizing, quenching and tempering
Surface hardness	HRC58 ~ 62 (excluding the carburizing prevention range)
Material	SCM415 Normalizing, or equivalent material

<Standard input gear A: For small motors>

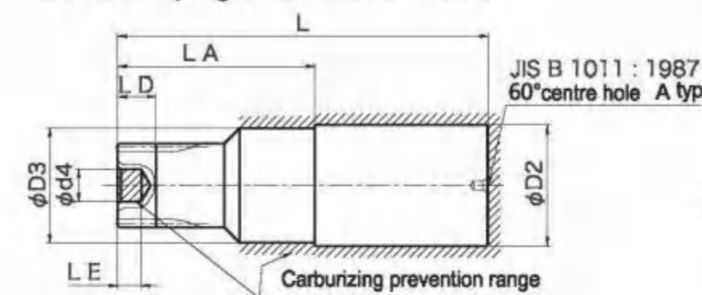

<Standard input gear B: For large motors>

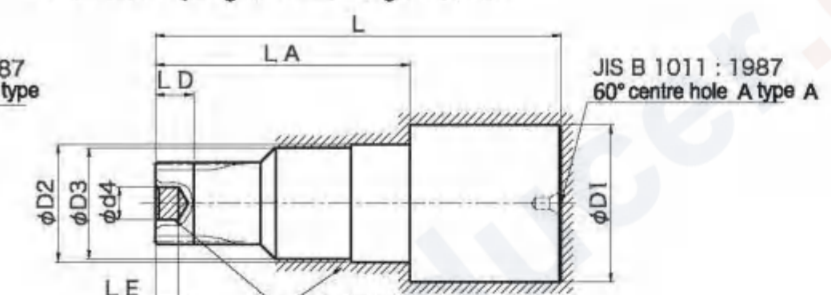

Note: The above drawing shows the shape before the additional machining is performed. Check the dimensions of each section.

\*Reference for additional machining  
Standard input gears come equipped with center holes and ground boss outer diameter (D1).  
When modifying them, use the center hole or boss outer diameter (D1) as the reference surface.

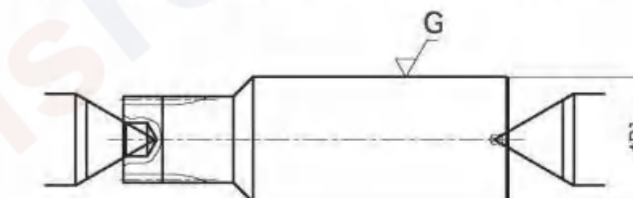

# Design points Input gears

## • Selection of the input gear type

There are the following two types of standard input gear:

Standard input gear A: For small motors

Standard input gear B: For large motors

Select the type of input gear to be used by referring to the tables below.

## • Design of the motor mounting area

<Design example 1: For straight shafts (attached to motor shaft tip)>

Applicable motor shaft diameters for standard input gear (mm)

Model	Standard input gear A	Standard input gear B
RV-6E	φ16 Following	
RV-20E, RV-15	Lower than φ14	φ14 Above
RV-40E, RV-30	Lower than φ19	φ19 Above
RV-80E, RV-60	Lower than φ24	φ24 Above
RV-110E	φ24 Following	

(Unit mm)

Model	Standard input gear A	Standard input gear B
RV-160E, RV-160	Lower than φ28	φ28 Above
RV-320E, RV-320	Lower than φ32	φ32 Above
RV-450E, RV-450	Lower than φ42	φ42 Above
RV-550	φ40 Following	

Note: Some models have only standard input gear A.

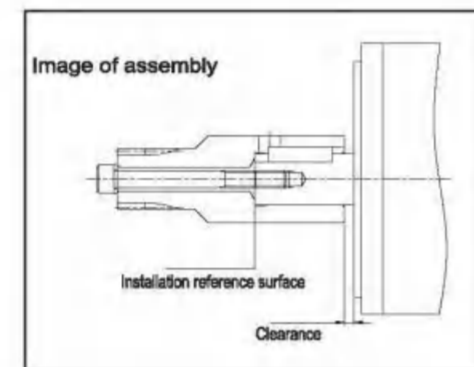
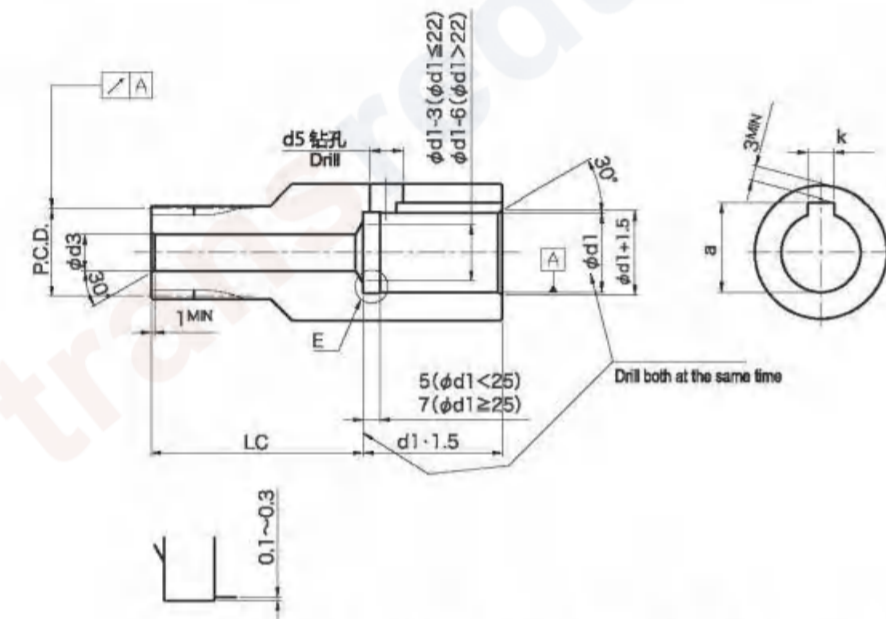

- Note 1. When a tapped hole is used for the motor shaft, fix the input gear to the motor shaft with a bolt.
2. For the bolt through hole diameter (d3), radial runout, and the shaft hole position (LC), refer to "Dimensions after modification" in the "Dimensions" table.
3. If the bolt through hole diameter (d3) is larger than the center hole diameter on the tooth surface side (d4), it is necessary to process the carburized surface. In such a case, confirm the applicable tools and processing conditions, etc.
4. The clearance hole diameter for the keyway (d5) is "keyway width (k) + 2 mm", approximately. (The clearance hole diameter must be larger than the keyway width (k).)
5. Design the motor shaft hole diameter (d1) according to the motor shaft diameter to be used.
6. For the keyway width (k) and keyway height (a), refer to the specifications of the key to be used.

<Design example 2: For straight shafts (attached to motor shaft base)>

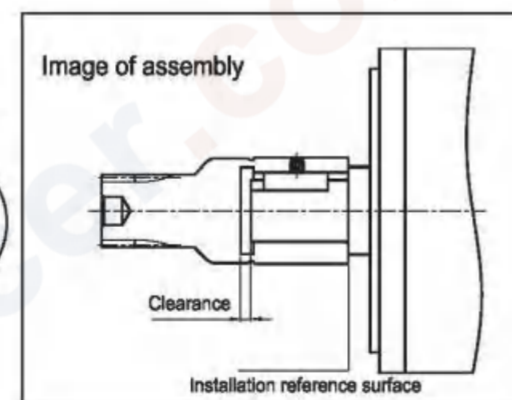
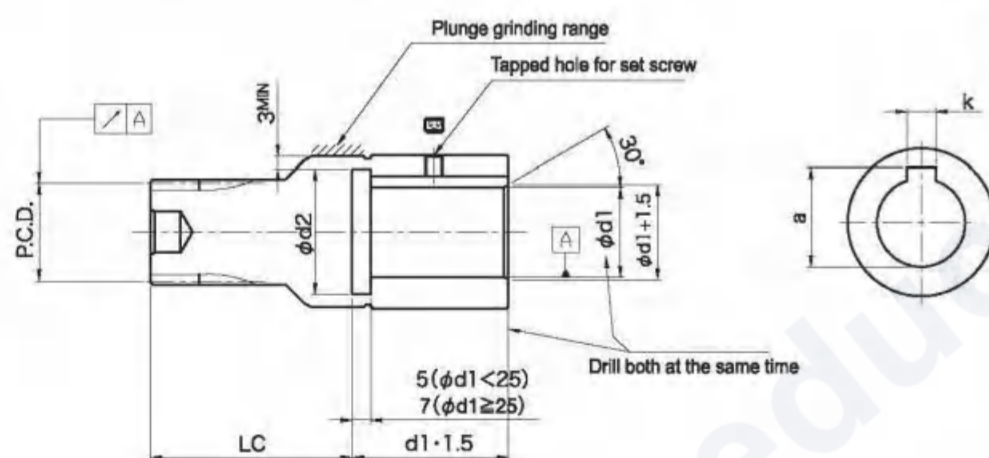

- Note 1. When a tapped hole is not used for the motor shaft, fix the input gear to the motor shaft with a set screw.
2. If a clearance hole for the keyway cannot be drilled due to some reason, such as the plunge grinding area being located on the outer periphery, create a recessed groove instead.
3. For the radial runout and the shaft hole position (LC), refer to "Dimensions after modification" in the "Dimensions" table.
4. Design the motor shaft hole diameter (d1) according to the motor shaft diameter to be used.
5. For the keyway width (k) and keyway height (a), refer to the specifications of the key to be used.
6. Design the diameter of the recessed groove for the keyway (d2) according to the following instructions.

## • Recessed groove diameter for keyway

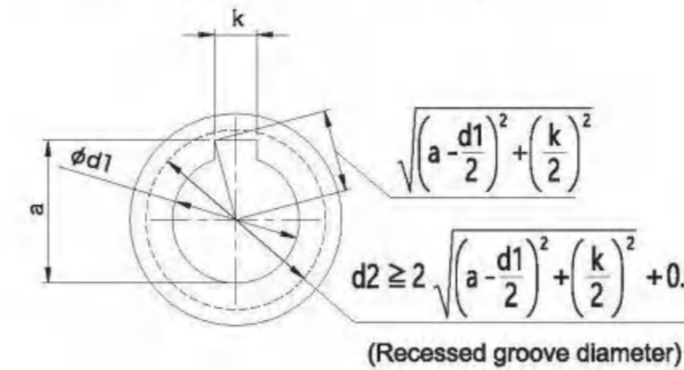

Set the diameter of the recessed groove (d2) so that it is larger than the corner of the keyway

$$d2 \geq 2 \sqrt{\left(a - \frac{d1}{2}\right)^2 + \left(\frac{k}{2}\right)^2} + 0.5$$

Although the above calculation formula is used in this example, design the diameter using appropriate values, based on the keyway tolerance, processing tolerance, etc. The following is an example of when the diameter of the recessed groove is selected based on the above calculation formula. Use it as a reference when designing.

(Unit mm)

φd1 Motor shaft hole diameter	k Keyway width	a Keyway height	φd2 Recessed groove diameter
8	3	9.4	12
9	3	10.4	13
10	4	11.8	15
11	4	12.8	16
14	5	16.3	20
15	5	17.3	21
16	5	18.3	22
17	6	19.8	24
19	6	21.8	26

(Unit mm)

φd1 Motor shaft hole diameter	k Keyway width	a Keyway height	φd2 Recessed groove diameter
22	8	25.3	31
24	8	27.3	33
25	8	28.3	34
28	8	31.3	37
32	10	35.3	41
35	10	38.3	44
38	10	41.3	47
38	12	41.3	47
42	12	45.3	51

<Design example 3: For tapered shafts>

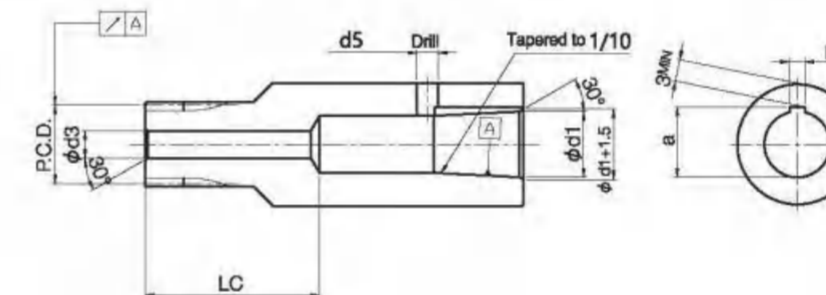

- Note 1. For the bolt through hole diameter (d3), radial runout, and the shaft hole position (LC), refer to "Dimensions after modification" in the "Dimensions" table.
2. Design the motor shaft hole diameter (d1) according to the motor shaft diameter to be used.
3. For the keyway width (k) and keyway height (a), refer to the specifications of the key to be used.
4. There are two ways to fix the tapered shaft to the motor shaft: draw nut and draw bolt. Fix the shaft using either of them, referring to the drawings below.
5. You can manufacture the draw nut and draw bolt on your own, or contact us.

## • When fixing with a draw nut

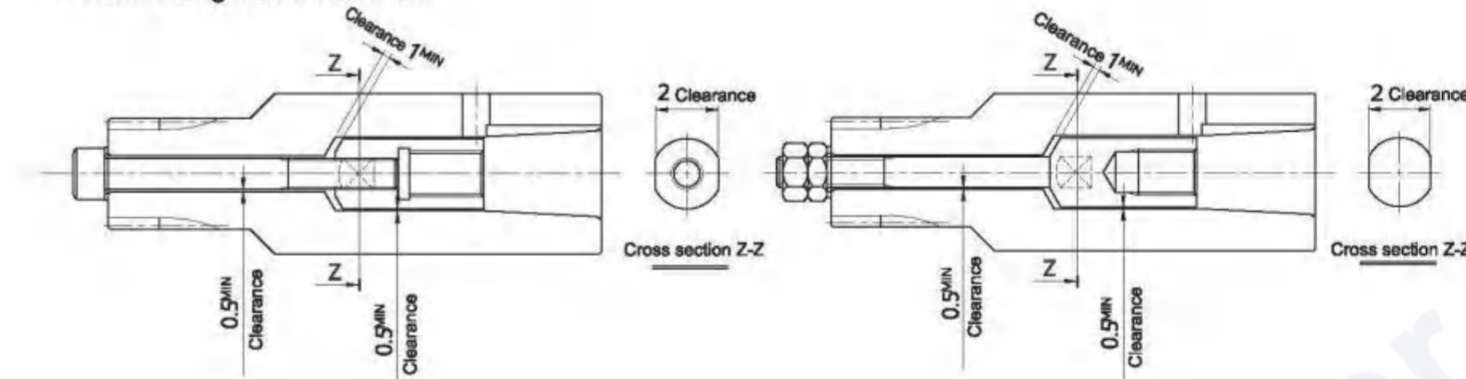

## • Design of the oil seal <Design example 4>

If a lip surface is required for the oil seal, manufacture a new input gear and quench the D2 section, and then perform plunge grinding.

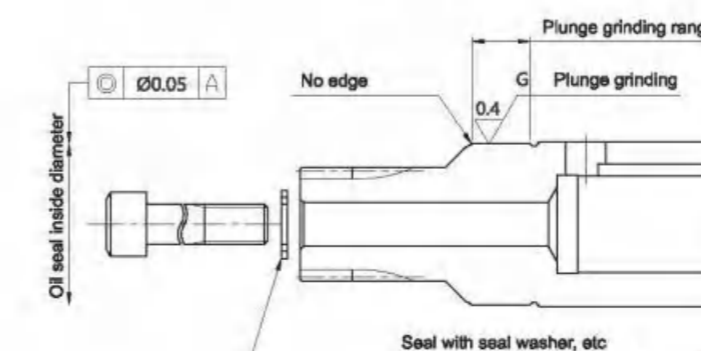

- Note 1. The design specifications vary depending on the oil seal manufacturer. When designing, be sure to confirm with the manufacturer of the oil seal to be used.
2. The standard input gear is not compatible with the oil seal surface. If the lip surface is required for the oil seal, manufacture a new input gear.
3. Rubber containing fluorine is recommended for the material of the oil seal.
4. When assembling the oil seal, be careful to avoid any contact between the lip section and the gear, as it causes scratches.
5. Design the oil seal assembly position so that the lip section of the oil seal does not fall off from the plunge grinding range.





## Gear tooth specifications

Refer to the specifications and materials shown in the following tables when designing a system with a processed or non-standard input gear. For a model or speed ratio other than those listed below, contact us.

Common specifications	
Tooth profile	Full depth
Pressure angle (°)	20
Precision	JIS B 1702: 1976 Grade 5

Spur gear tooth surface hardness and material	
Heat treatment	Carburizing, quenching and tempering
Surface hardness	HRC 58 ~ 62
Effective case depth <HV 513>(mm)	0.3 ~ 0.7 ※1
Material	SCM415 Normalizing
Alternate material	SCM420 Normalizing

The value will differ depending on the module.

Module	1 or lower	More than 1
Effective case depth <HV 513>(mm)	0.2 ~ 0.6	0.3 ~ 0.7

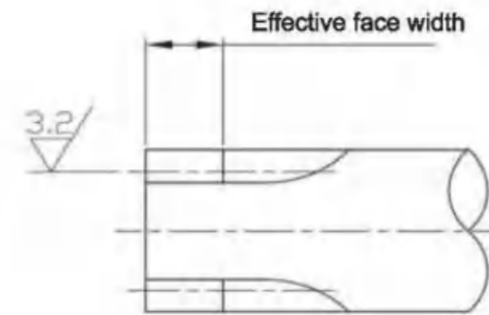

## Input gear tooth specifications for each model

Model	RV-6E						
	Ratio code	31	43	53.5	59	79	103
Module	1	1.25	1	1	1.25	1	
No. of teeth	22	15	16	15	10	10	
Shift coefficient	+0.04	+0.25	+0.5	+0.5	+0.5	+0.5	
Base tangent length (mm)	7.716 <sup>-0.017</sup> <sub>-0.042</sub>	9.702 <sup>-0.017</sup> <sub>-0.042</sub>	4.994 <sup>-0.017</sup> <sub>-0.042</sub>	4.980 <sup>-0.017</sup> <sub>-0.042</sub>	6.138 <sup>-0.017</sup> <sub>-0.042</sub>	4.910 <sup>-0.017</sup> <sub>-0.042</sub>	
No. of teeth	(3个)	(3个)	(2个)	(2个)	(2个)	(2个)	
Min. effective face width (mm)	6	6	6	6	6	6	

Model	RV-20E, RV-15						
	Ratio code	57	81	105	121	141	161
Module	1.5	1.5	1.5	1.5	1.0	0.9	
No. of teeth	15	12	10	9	12	12	
Shift coefficient	+0.2	+0.4	+0.5	+0.5	+0.5	+0.5	
Base tangent length (mm)	7.163 <sup>-0.017</sup> <sub>-0.042</sub>	7.305 <sup>-0.017</sup> <sub>-0.042</sub>	7.365 <sup>-0.017</sup> <sub>-0.042</sub>	7.344 <sup>-0.017</sup> <sub>-0.042</sub>	7.890 <sup>-0.017</sup> <sub>-0.042</sub>	7.101 <sup>-0.017</sup> <sub>-0.042</sub>	
No. of teeth	(2个)	(2个)	(2个)	(2个)	(3个)	(3个)	
Min. effective face width (mm)	8	8	8	8	8	8	

Model	RV-40E, RV-30					
	Ratio code	57	81	105	121	153
Module	1.5	1.5	2.0	1.5	1.5	
No. of teeth	20	16	10	12	10	
Shift coefficient	0	+0.1	+0.5	+0.5	+0.5	
Base tangent length (mm)	11.491 <sup>-0.023</sup> <sub>-0.061</sub>	7.081 <sup>-0.023</sup> <sub>-0.061</sub>	9.821 <sup>-0.023</sup> <sub>-0.061</sub>	11.835 <sup>-0.023</sup> <sub>-0.061</sub>	7.365 <sup>-0.023</sup> <sub>-0.061</sub>	
No. of teeth	(3个)	(2个)	(2个)	(3个)	(2个)	
Min. effective face width (mm)	10	10	10	10	10	

Model	RV-80E, RV-60						
	Ratio code	57	81(RV-60用)	81(RV-80E用)	101	121	153
Module	1.75	2.0	1.75	2.0	1.75	1.75	
No. of teeth	20	14	16	12	12	10	
Shift coefficient	0	+0.5	+0.5	+0.5	+0.5	+0.5	
Base tangent length (mm)	13.406 <sup>-0.028</sup> <sub>-0.066</sub>	15.837 <sup>-0.028</sup> <sub>-0.066</sub>	13.906 <sup>-0.028</sup> <sub>-0.066</sub>	15.781 <sup>-0.028</sup> <sub>-0.066</sub>	13.808 <sup>-0.028</sup> <sub>-0.066</sub>	8.593 <sup>-0.028</sup> <sub>-0.066</sub>	
No. of teeth	(3个)	(3个)	(3个)	(3个)	(3个)	(2个)	
Min. effective face width (mm)	10	10	10	10	10	10	

Model	RV-110E				
	Ratio code	81	111	161	175.28
Module	1.25	1.25	1.25	1.25	
No. of teeth	25	20	15	14	
Shift coefficient	0	0	+0.3	+0.3	
Base tangent length (mm)	9.663 <sup>-0.028</sup> <sub>-0.066</sub>	9.576 <sup>-0.028</sup> <sub>-0.066</sub>	9.746 <sup>-0.028</sup> <sub>-0.066</sub>	9.727 <sup>-0.028</sup> <sub>-0.066</sub>	
No. of teeth	(3个)	(3个)	(3个)	(3个)	
Min. effective face width (mm)	13	13	13	13	

Model	RV-160E, RV-160					
	Ratio code	81	101	129	145	171
Module	2.5	2.5	2.5	1.5	1.25	
No. of teeth	14	12	10	15	16	
Shift coefficient	+0.3	+0.5	+0.5	+0.5	+0.5	
Base tangent length (mm)	19.453 <sup>-0.035</sup> <sub>-0.085</sub>	19.726 <sup>-0.035</sup> <sub>-0.085</sub>	12.276 <sup>-0.035</sup> <sub>-0.085</sub>	11.899 <sup>-0.035</sup> <sub>-0.085</sub>	9.933 <sup>-0.035</sup> <sub>-0.085</sub>	
No. of teeth	(3个)	(3个)	(2个)	(3个)	(3个)	
Min. effective face width (mm)	15	15	15	15	15	

Model	RV-320E, RV-320							
	Ratio code	81	101	118.5	129	141	171	185
Module	2.0	2.0	2.0	2.0	2.0	2.0	2.0	1.5
No. of teeth	21	18	16	15	14	12	15	
Shift coefficient	0	+0.5	+0.5	+0.5	+0.5	+0.5	+0.5	
Base tangent length (mm)	15.349 <sup>-0.035</sup> <sub>-0.085</sub>	15.949 <sup>-0.035</sup> <sub>-0.085</sub>	15.893 <sup>-0.035</sup> <sub>-0.085</sub>	15.865 <sup>-0.035</sup> <sub>-0.085</sub>	9.933 <sup>-0.035</sup> <sub>-0.085</sub>	15.781 <sup>-0.035</sup> <sub>-0.085</sub>	11.899 <sup>-0.035</sup> <sub>-0.085</sub>	
No. of teeth	(3个)	(3个)	(3个)	(3个)	(2个)	(3个)	(3个)	
Min. effective face width (mm)	16	16	16	16	16	16	16	

Model	RV-450E, RV-450							
	Ratio code	81	101	118.5	129	154.8	171	192.4
Module	2.25	2.25	2.25	2.25	2.25	2.25	2.25	1.75
No. of teeth	21	18	16	15	13	12	14	
Shift coefficient	0	+0.556	+0.556	+0.556	+0.556	+0.556	+0.556	
Base tangent length (mm)	17.267 <sup>-0.035</sup> <sub>-0.085</sub>	18.029 <sup>-0.035</sup> <sub>-0.085</sub>	17.966 <sup>-0.035</sup> <sub>-0.085</sub>	17.934 <sup>-0.035</sup> <sub>-0.085</sub>	17.871 <sup>-0.035</sup> <sub>-0.085</sub>	17.840 <sup>-0.035</sup> <sub>-0.085</sub>	13.944 <sup>-0.035</sup> <sub>-0.085</sub>	
No. of teeth	(3个)	(3个)	(3个)	(3个)	(3个)	(3个)	(3个)	
Min. effective face width (mm)	18	18	18	18	18	18	18	

Model	RV-550				
	Ratio code	123	141	163.5	192.4
Module	2.0	2.0	2.0	2.0	
No. of teeth	20	18	16	14	
Shift coefficient	0	+0.3	+0.3	+0.3	
Base tangent length (mm)	15.321 <sup>-0.035</sup> <sub>-0.085</sub>	15.675 <sup>-0.035</sup> <sub>-0.085</sub>	15.619 <sup>-0.035</sup> <sub>-0.085</sub>	15.563 <sup>-0.035</sup> <sub>-0.085</sub>	
No. of teeth	(3个)	(3个)	(3个)	(3个)	
Min. effective face width (mm)	22	22	22	22	

## Input spline gear tooth specifications for each model

Refer to the specifications shown in the following tables when designing with a processed or non-standard input spline. The specifications of the hardness and material are the same as those of the input gear.

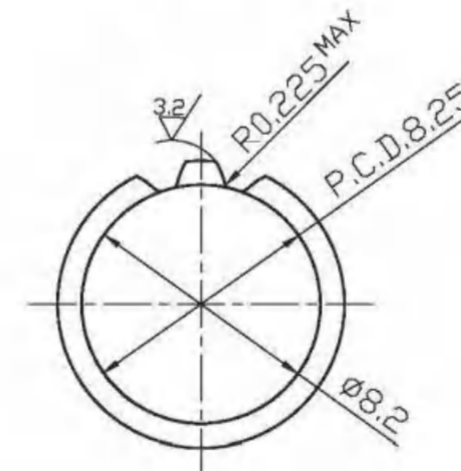

Detailed drawing of spline section

RV-6E		
Automotive involute spline (shaft) 10x11x0.75 (JIS D2001)		
Shift coefficient	+0.9667	
Tool	Tool profile	Stub tooth
	Module	0.75
	Pressure angle	20°
No. of teeth	11	
Reference pitch diameter	8.25	
Face width	Over-pin diameter	11.120 <sup>-0.011</sup> <sub>-0.076</sub>
	Pin diameter φ1.4 (Pin diameter φ1.5)	{ 11.380 <sup>-0.011</sup> <sub>-0.076</sub> }
Grade	b	
Remarks	Side fit	

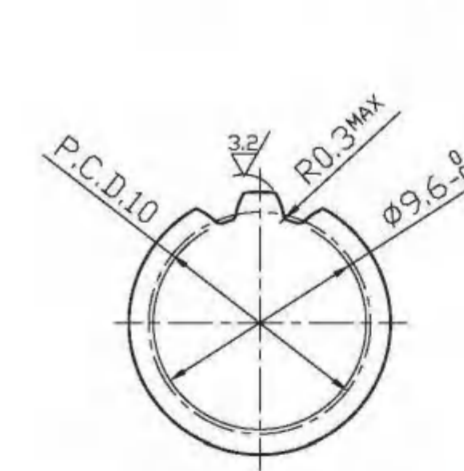

Detailed drawing of spline section

RV-20E		
Automotive involute spline (shaft) 12x10x1.0 (JIS D2001)		
Shift coefficient	+0.8	
Tool	Tool profile	Stub tooth
	Module	1.0
	Pressure angle	20°
No. of teeth	10	
Reference pitch diameter	10	
Face width	Over-pin diameter	13.564 <sup>-0.012</sup> <sub>-0.078</sub>
	Pin diameter φ1.8 (Pin diameter φ2.0)	{ 13.564 <sup>-0.012</sup> <sub>-0.078</sub> }
Grade	b	
Remarks	Side fit	

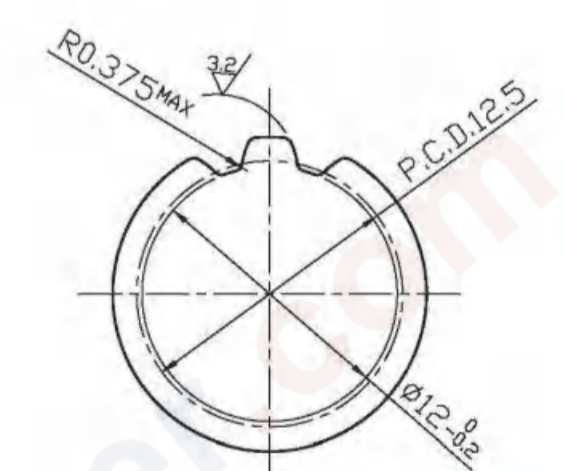

Detailed drawing of spline section



RV-40E, RV-80E		
Automotive involute spline (shaft) 15x10x1.25 (JIS D2001)		
Shift coefficient	+0.8	
Tool	Tool profile	Stub tooth
	Module	1.25
	Pressure angle	20°
No. of teeth	10	
Reference pitch diameter	12.5	
Face width	Over-pin diameter	16.954 <sup>-0.012</sup> <sub>-0.078</sub>
	Pin diameter φ2.25 (Pin diameter φ2.381)	{ 17.301 <sup>-0.012</sup> <sub>-0.078</sub> }
Grade	b	
Remarks	Side fit	

# Design point Lubricant

## Amount of lubricant

RV precision gearbox are not applied with lubricant when shipped. Be sure to design your equipment so that the necessary amount of lubricant can be applied. (When pneumatic pressure is used for applying the lubricant, set the pressure below 0.03 MPa.)

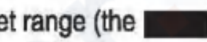
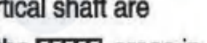
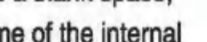
### E Series

The amount of lubricant required for the gearbox and the target range (the  areas in the diagram) when the gearbox is installed in the horizontal shaft are indicated in Fig. 1 and when the gearbox is installed in the vertical shaft are indicated in Fig. 2. Each amount does not include the space (the  areas in the diagram) on the motor mounting side. Therefore, if there is a blank space, also fill the space. Leave a space about 10% of the total volume of the internal capacity of the gearbox (the  areas in the diagram) and the space on the motor mounting side (the  areas in the diagram).

#### Horizontal shaft installation

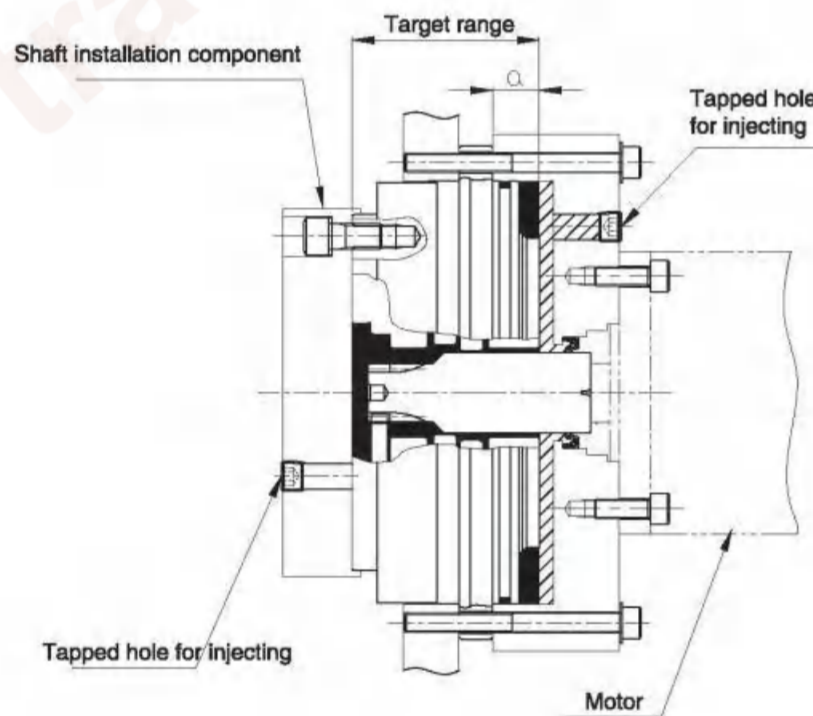

#### Vertical shaft installation (with shaft facing upward)

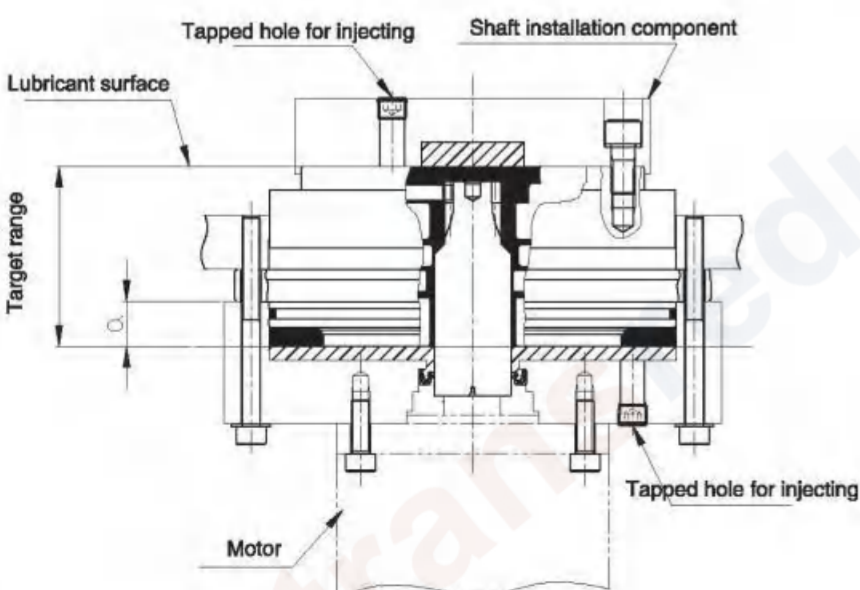

### E Series

Model	Required amount		a (mm) Dimensions
	(cc)	(g) <sup>*1</sup>	
RV-6E	42	(38)	17
RV-20E	87	(78)	15
RV-40E	195	(176)	21
RV-80E(1) <sup>*2</sup>	383	(345)	21
RV-80E(2) <sup>*2</sup>	345	(311)	21
RV-110E	432	(389)	6.5
RV-160E	630	(567)	10.5
RV-320E	1,040	(936)	15.5
RV-450E	1,596	(1,436)	18

### E Series

Vertical shaft installation (with shaft facing downward)

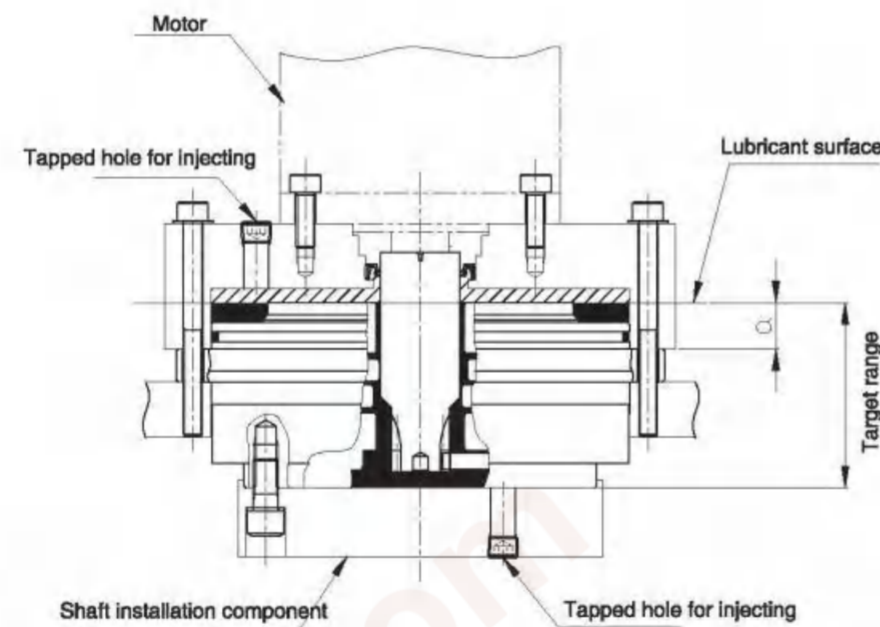





### E Series

Model	Required amount		a (mm) Dimensions
	(cc)	(g) <sup>*1</sup>	
RV-6E	48	(43)	17
RV-20E	100	(90)	15
RV-40E	224	(202)	21
RV-80E(1) <sup>*2</sup>	439	(395)	21
RV-80E(2) <sup>*2</sup>	396	(356)	21
RV-110E	495	(446)	6.5
RV-160E	694	(625)	10.5
RV-320E	1,193	(1,074)	15.5
RV-450E	1,831	(1,648)	18

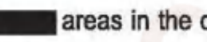
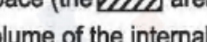
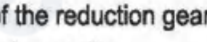
### C Series

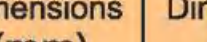
#### For the C series

The amount of lubricant required for the gearbox and the target range (the  areas in the diagram) when the gearbox is installed in the horizontal shaft are indicated in Fig. 3 and when the gearbox is installed in the vertical shaft are indicated in Fig. 4. If there is a blank space inside (e.g., when a center tube is used), exclude the volume of the blank space. Each amount does not include the space (the  areas in the diagram) on the motor mounting side. Therefore, if there is a blank space, also fill the space. Leave a space about 10% of the total volume of the internal capacity of the gearbox (the  areas in the diagram) and the space on the motor mounting side (the  areas in the diagram). The space on the motor mounting side (the  areas in the diagram) includes the center gear external capacity (the  areas in the diagram) and the external capacity of the reduction gear (the  areas in the diagram). Therefore, when calculating the volume of the space on the motor mounting side, exclude the relevant external capacity.

Model	Required amount		a Dimensions (mm)	b Dimensions (mm)	Gearbox external capacity (cc)	Center gear external capacity (cc)
	(cc)	(g) <sup>*1</sup>				
RV-10C	147	(132)	9.5	16.85	4	70
RV-27C	266	(239)	10	21.35	10	83
RV-50C	498	(448)	11	23.35	21	208
RV-100C	756	(680)	9.9	29.45	57	369
RV-200C	1,831	(1,648)	18.5	37.7	93	642
RV-320C	3,536	(3,182)	25	46.75	197	1,275
RV-500C	5,934	(5,341)	32	49.7	310	1,803

#### Horizontal shaft installation

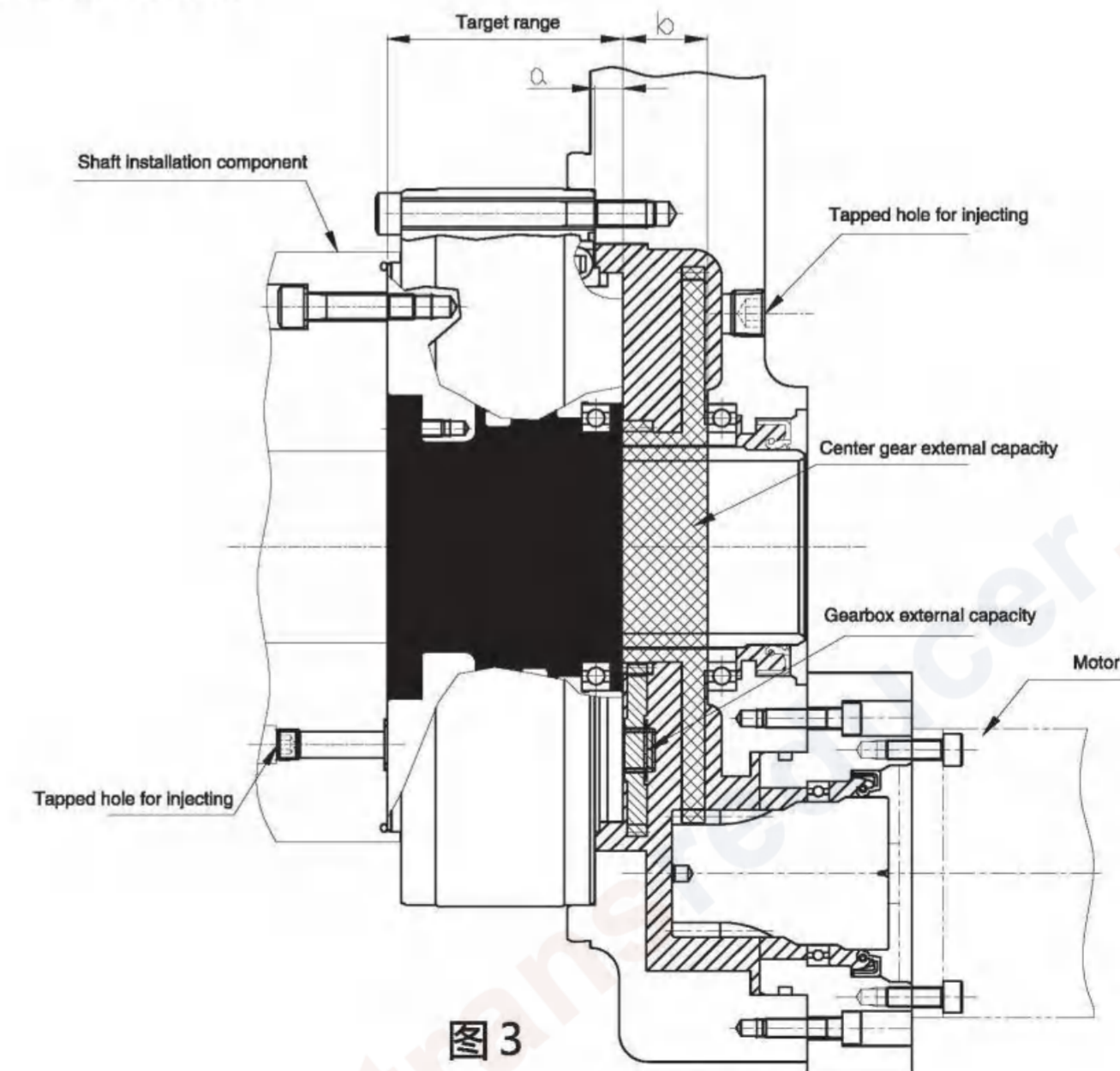

# Design point Lubricant

Vertical shaft installation (with shaft facing upward)

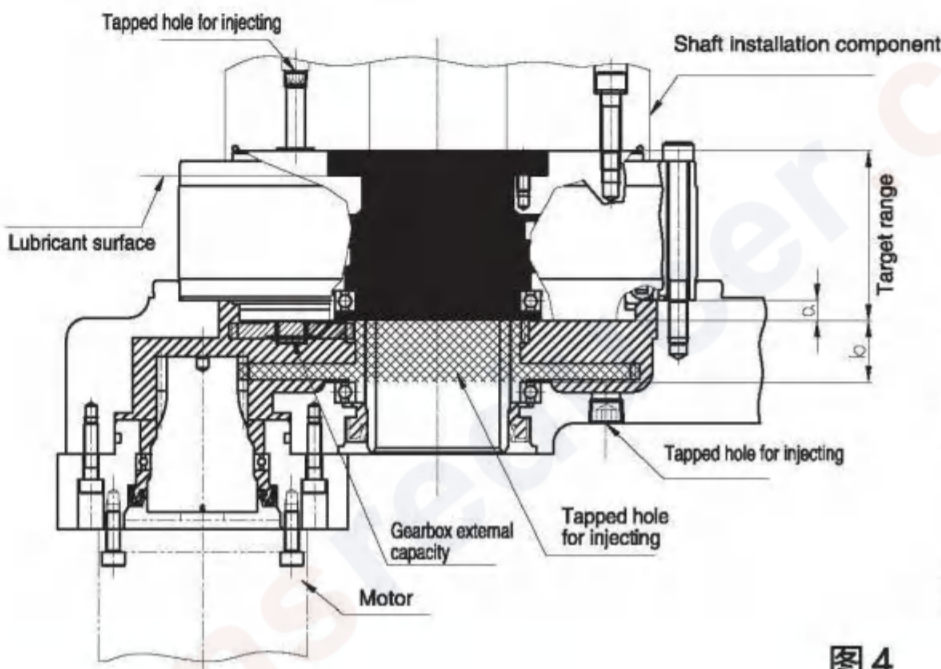

Vertical shaft installation (with shaft facing downward)



图 4

Model	Required amount		a (mm) Dimensions	b (mm) Dimensions	(cc) Gearbox external capacity	(cc) Center gear external capacity
	(cc)	(g)※1				
RV-10C	167	(150)	9.5	16.85	4	70
RV-27C	305	(275)	10	21.35	10	83
RV-50C	571	(514)	11	23.35	21	208
RV-100C	857	(771)	9.9	29.45	57	369
RV-200C	2,076	(1,868)	18.5	37.7	93	642
RV-320C	4,047	(3,642)	25	46.75	197	1,275
RV-500C	6,900	(6,210)	32	49.7	310	1,803

\*1. Density of VIGOGREASE RE0: 0.9 g/cc

## Grease replacement time

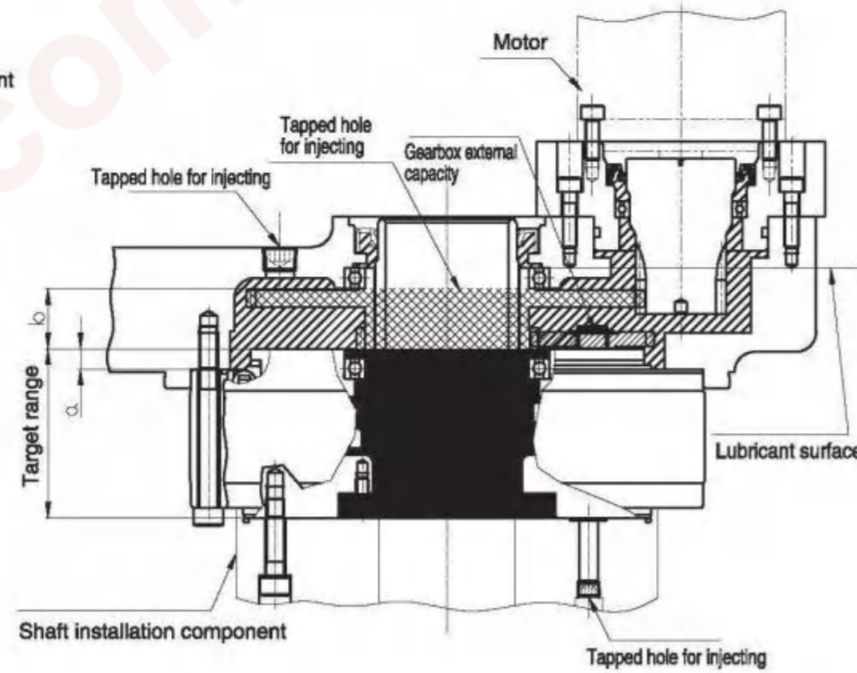
During proper operation of the gearbox, the standard grease replacement time due to lubricant degradation is 20,000 hours.

However, when operation involves a gearbox surface temperature above 40°C (the hatched area in the right diagram), the state of the lubricant should be checked in advance and the grease replaced earlier as necessary.

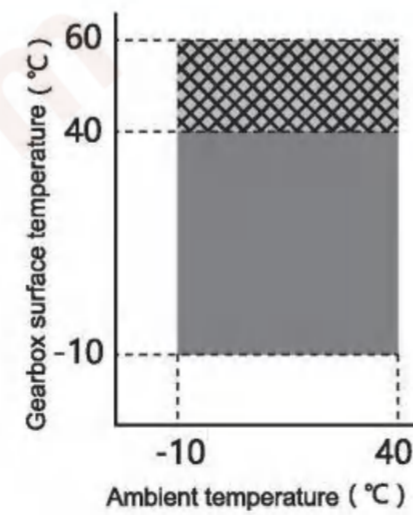

## Running-in operation

It is recommended that the running-in operation is performed after the our specified lubricant is added. Abnormal noise or torque irregularity may occur during operation, depending on the characteristics of the lubricant. There is no problem with the quality when the symptom disappears after the running-in operation is performed for 30 minutes or more (until the surface temperature of the gearbox body reaches around 50°C).

# Please supply us the following items when ordering gearbox

## 1. Site of use

Name of Machine: \_\_\_\_\_

Applied to: \_\_\_\_\_

## 2. Model

RV- \_\_\_\_\_

## 3. Conditions of load

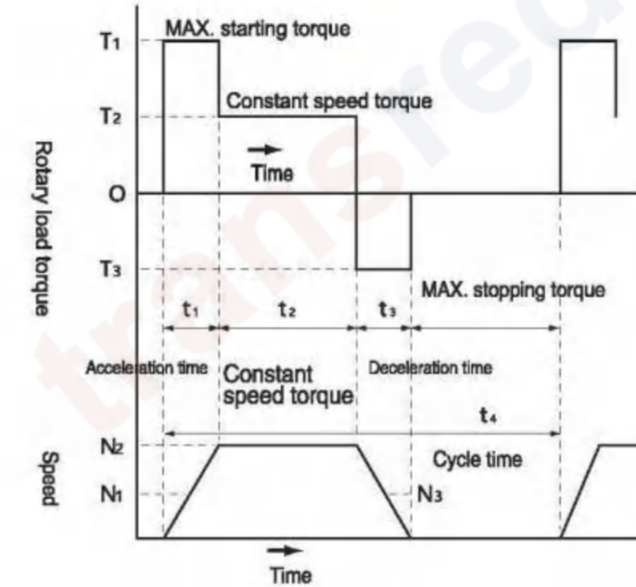

	For starting (MAX)	For stopping (MAX)	Cycle time
Load torque (Nm)	T <sub>1</sub>	T <sub>2</sub>	T <sub>3</sub>
Speed (rpm)	N <sub>1</sub>	N <sub>2</sub>	N <sub>3</sub>
Time (s)	t <sub>1</sub>	t <sub>2</sub>	t <sub>3</sub>
Working hours	Cycle/Day	Day/Year	Year

## 4. External load conditions

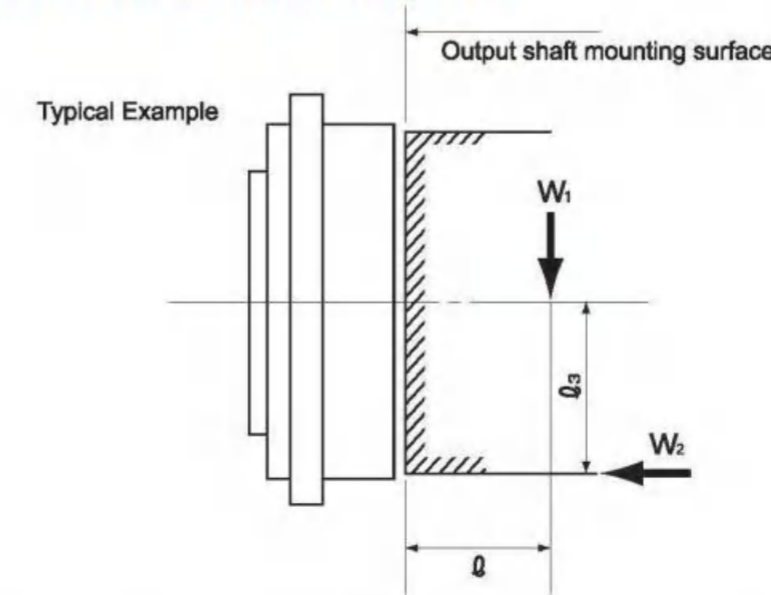

(W<sub>1</sub>): (N) (l): (mm)  
(W<sub>2</sub>): (N) (l<sub>2</sub>): (mm)

## 5. Operating environment

Operating environment temperature \_\_\_\_\_°C

## 6. Installation

Horizontal Vertical  Upper motor  Lower Motor

Illustration for installation

## 7. Input gear specification

Reduction speed ratio i= \_\_\_\_\_

Standard size  Other

Input gear Prepared by  User  Our company

Required dimension of input gear

## 8. Driving section specification

Servo motor  Other ( )

Power: (kW)

Rated torque: (Nm)

Speed: (rpm)

Shaft size: (mm)

## 9. Other

( )

# FHA-E SERIES

DIRECT OUTPUT, TIGHT ENGAGEMENT  
AND HIGH PRECISION



## Overview

- Type : FHA-5E~FHA-450E
- Backlash:  $\leq 1-5$  Arc.min
- Ratio : 1/35 ~ 1/140
- Capacity: 0.1KW ~ 15KW
- Rotation : Shaft Run or Case Run
- Rated output torque: 60NM ~ 5100NM

## FEATURE OF ROLLER REDUCER

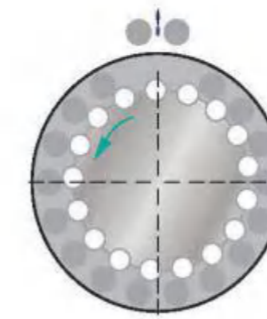

▲ Load-decentralized technology via multi-gear engagement, enhance raise impact capability rapidly.



▲ Conventional spur or helical gear must bear over-load impact due to merely one-tooth engagement in each mesh.

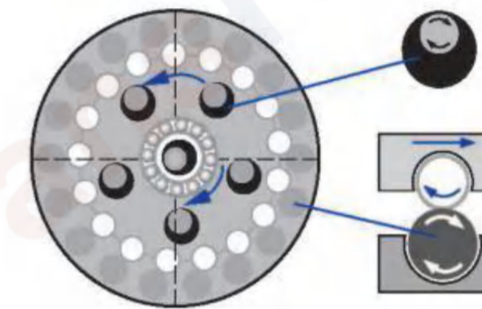

▲ Drive of external & internal rollers involved sliding and rotation-self, obtain extremely high efficiency.

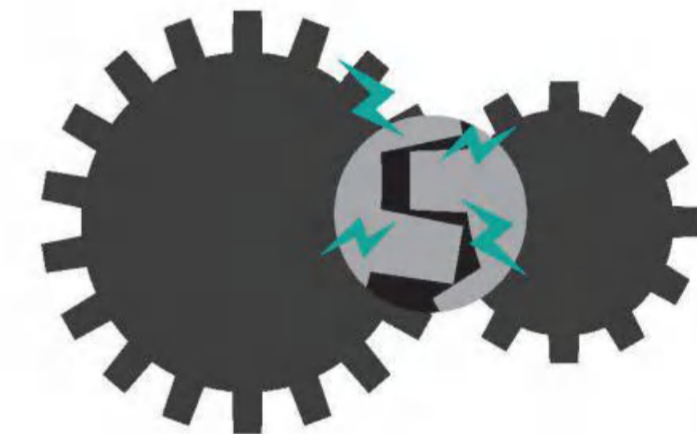

▲ The unsmooth torque transmission caused by the abrasion or interference of gear in conventional mechanism.

### Innovative transmission, significant advantage

The features and benefits: With advantages of Harmonic gear drive without the weakness of flexspline. With high ratio of planetary gear drive without the length concern. With benefit of high loading capacity of cycloid drive without obvious vibration.

### Low sliding loss · high efficiency

All sliding parts composed of rollers, whose operation involve sliding and rolling at the same time, therefore the mechanism loss is almost neglected and obtained extremely high efficiency. The efficiency up to 95% under one stage reduction.

### Smooth operation · low noise

Multi-teeth mesh simultaneous, high overlap-coefficient, counterbalanced twin-disc structure offset vibration, roller contact with proper gap could avoid the interference like gear, above characteristics could minimize the noise and vibration effectively.

### High precision , low backlash

The backlash could be eliminated due to multi-teeth engagement, therefore the transmission deviation is merely 25% of the conventional gear reducer.

### Long diameter of wave exciter , high torque output

Due to regular characteristic of rolling wave , the diameter of rolling wave of roller transmission is bigger than other conventional disc or carrier , so the torque is higher accordingly .

### High ratio , compact structure

The number of rollers on the roller disc is equal to ratio , single stage can obtain high ratio. Output and input shaft are on co-axis and mechanisms are robust and space-saving, so the dimension is more compact compared to the worm reducer and gear reducer especially on the high ratio ones.

### Multi-teeth engagement , high loading capability

Half rollers mesh simultaneously of twin-disc roller mechanism , compared to only one tooth mesh of conventional reducer , whose loads capacity is higher than worm reducer and gear reducer .

### Roller tooth , long service life

Innovative roller drive design , excellent handcraft , high manufacturing technique and unique roller outline , no broken-teeth phenomenon , make overall robust mechanism , free to maintenance and durable service life.

### Low energy consumption , better economic benefit

High torque output and high efficiency, low energy consumption, low operation load, better economical benefit.

### Hollow design , direct output

C TYPE-hollow shaft type , design-friendly , allows to array the routing hydraulic tubes and electrical cables through the reducer. Coupling and motor flange provide easy motor mounting.

## FEATURE OF ROLLER REDUCER

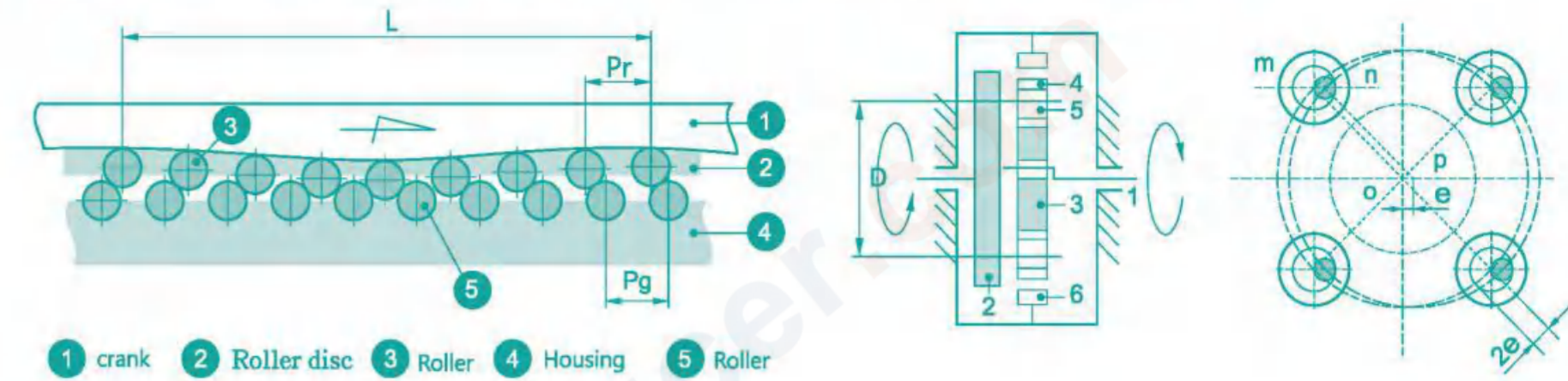

### ▲ Stretch

First · stretch the basic roller wave transmission as the figure 1 · when crank(1) moved to certain direction , propel roller (3) of roller disc (2) to mesh with roller (5) of housing (4) , then rollers (3) of roller disc (2) are moved adversely , rollers (3) also are limited in the pitch ( $P_r$ ) of roller disc (2) · the rollers are propelled continuously , one by one , no dead point and meet below formula :  $L = T_g \times P_g = T_r \times P_r$   
 $T_r$  and  $T_g$  represent the number of roller(3) and roller(5) separately.

### ▲ Output

The roller disc (3) are propelled by the crank(1) · make the high speed revolution and the low speed rotation itself at the same time. Retarding rotation could propel shaft pin (5) via roller (4) , (PS.: shaft pin (5) mounted on output shaft (2) directly or indirectly) , we can easily prove : the 4 points of m , n , o , p form a parallelogram , therefore output speed is equal to low speed of roller disc (3). Shown as the above figure.

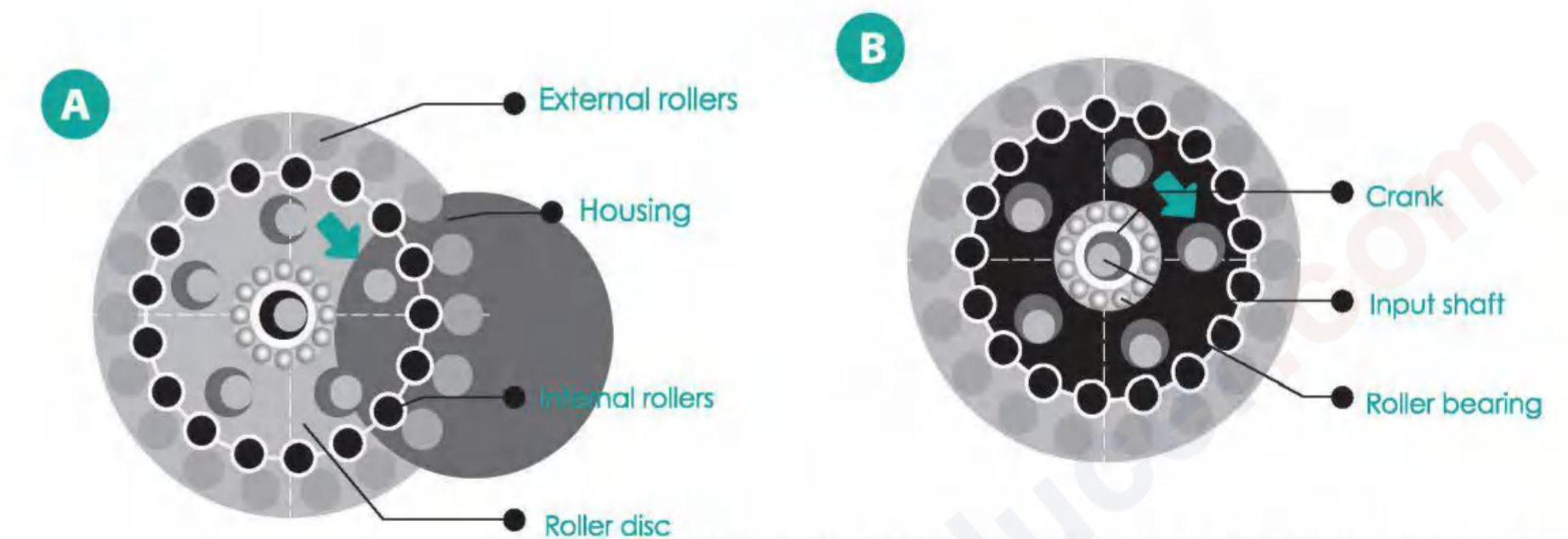

1. Cylindrical external rollers mounted in robust housing.
2. Cylindrical internal rollers mounted in precision roller disc.
3. Input shaft rotate clockwise to synchronously drive crank rotation clockwise.
4. Roller disc turns counter-clockwise eccentrically propelled by the crank.
5. Internal rollers turn counter-clockwise accompanied with roller disc.

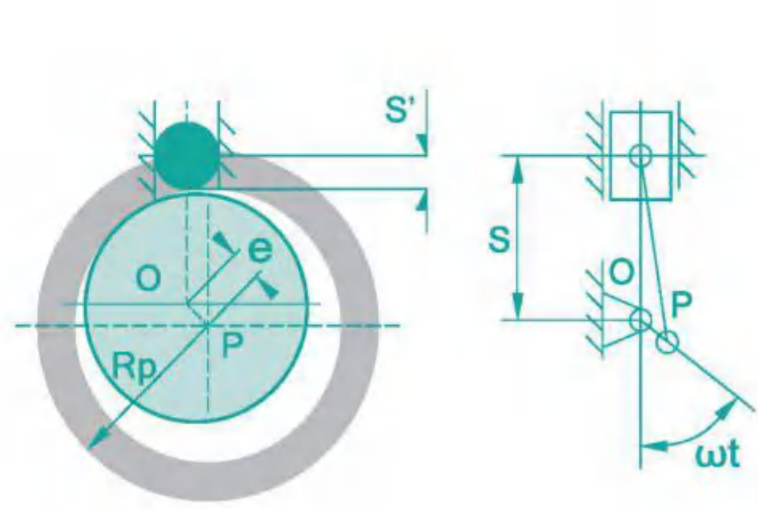

**▲ Rolling wave**

The housing(4) adopting the profile of roller(5) , and the rolling wave adopted standard crank , both interaction frequency issimilar to motion of the crank-slide mechanism shown as the above figure.

$$S = R_p \cos \beta - e \cos \omega t$$

$$S' = \sqrt{R_p^2 - e^2 \sin^2 \omega t - e \cos \omega t} - R_O$$

- $R_p$  = Eccentric circle theoretical contour radius
- $R_O$  = Radius of Shock Base Circle
- $\beta$  = Angle between connecting rod and rail center line
- $e$  = Eccentricity
- $\omega$  = Eccentric fillet speed
- $t$  = Time parameter

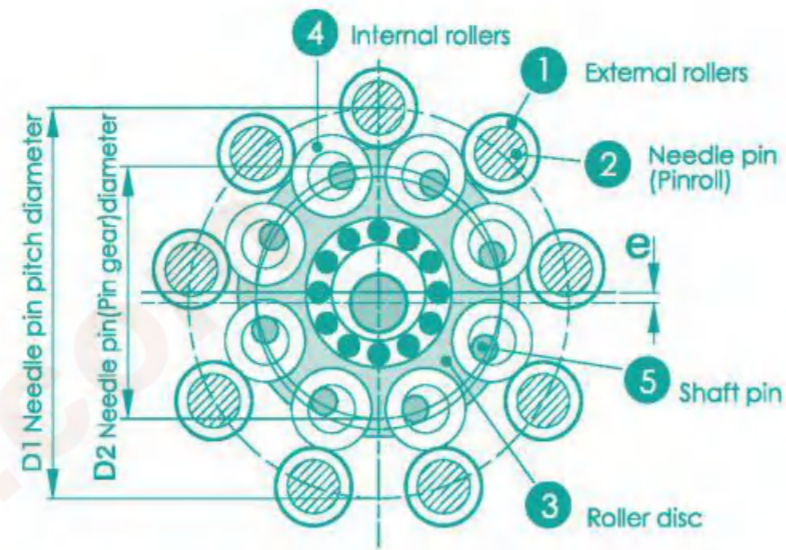

**▲ Assembly**

The detail shown as the above figure, when internal rollers(4) of roller disc (3) are small so that shaft pin(5) can't be inserted into internal rollers , especially high ratio status , shaft pin(5) is used to being put in roller disc (3)directly, also maintain the same output speed. Basically , this system is rolling contact completely with very low mechanical loss and obtain very high efficiency.

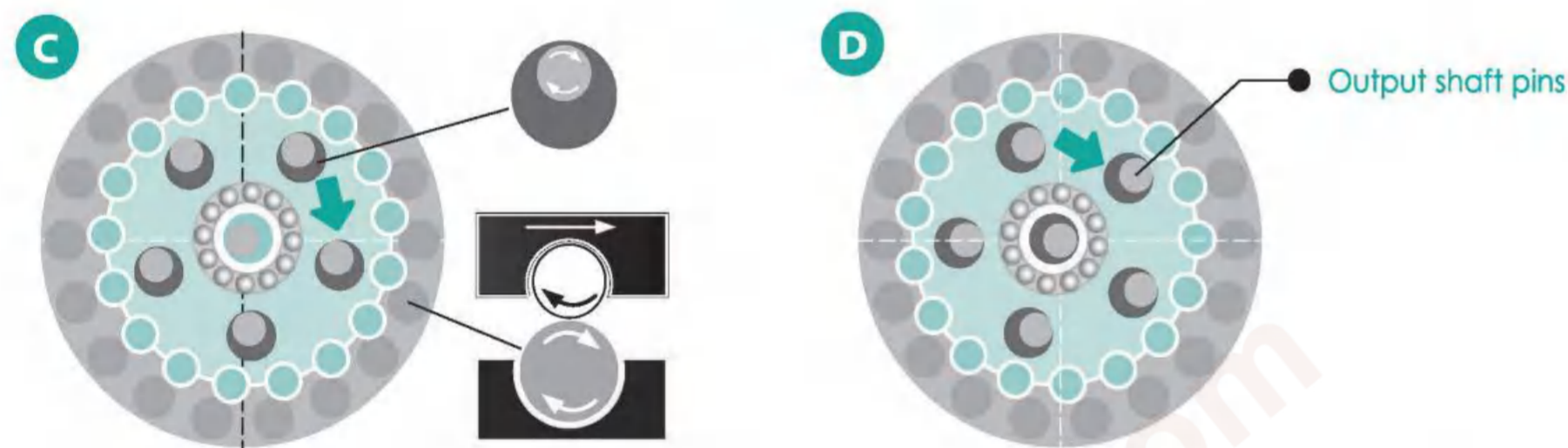

6.While internal rollers turning counter-clockwise accompanied with roller disc,this make rotation of internal rollers and external rollers separately follow individual center axis due to mesh transmission.

7.Because the internal/external rollers can rotate freely around individual center,we called this transmission type "innovative revolution-rotation roller drive mechanism"

8.Output shaft pins propelled with roller disc turn revolution counter-clockwise; output shaft connected with output shaft pins also turns counter-clockwise.

9.As figure A to D, input shaft turns for one cycle, internal rollers turn for one tooth in adverse direction.As a result, the number of teeth of internal rollers is equal to the reduction ratio.

# FEATURE OF ROLLER REDUCER



Rotary Table/Position Device/ 7<sup>th</sup>/8<sup>th</sup> Axis application



First Axis Of Robot



Palletizing Robot



Automation Equipment

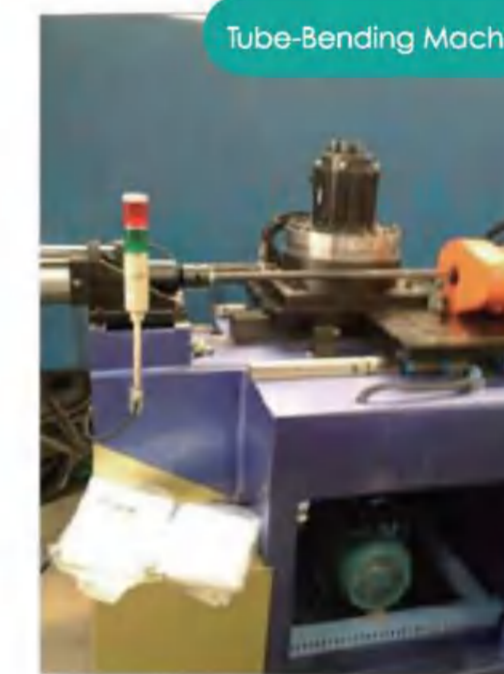

Tube-Bending Machine



Auto Labeling Machine



Electroheads



SCARA



Welding Robot and Auxiliary



Transportation Robot

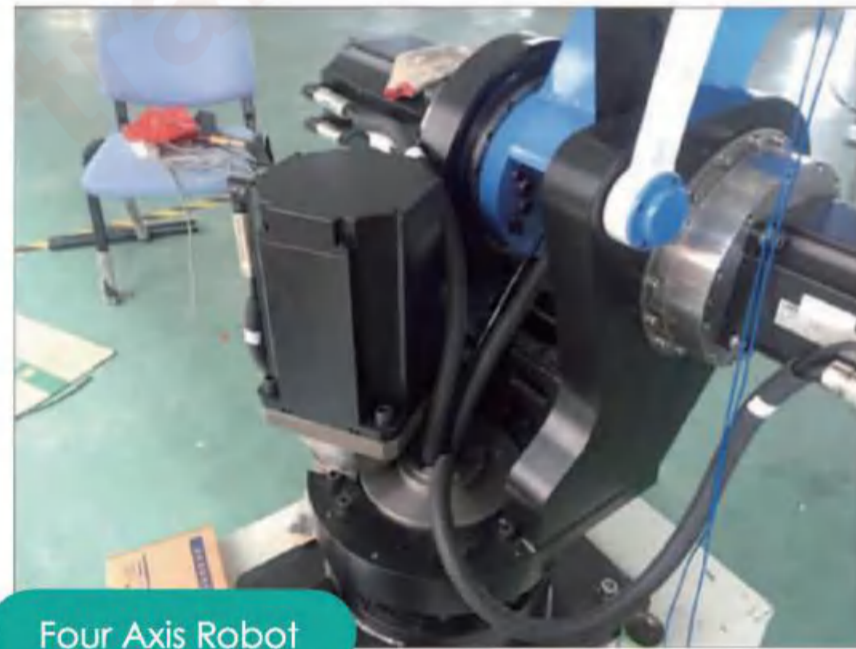

Four Axis Robot

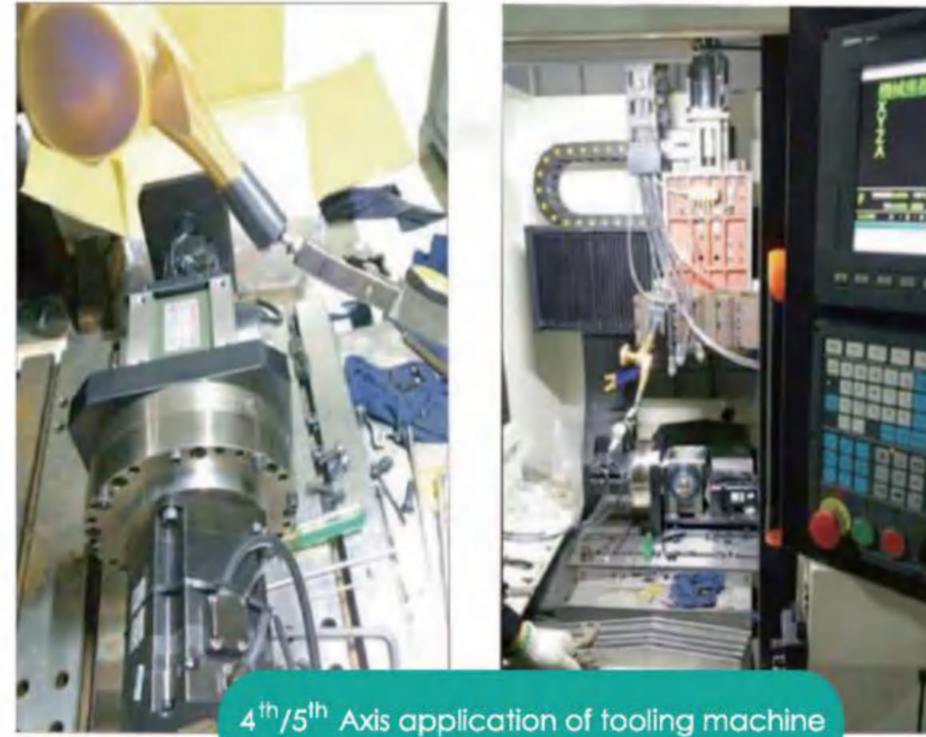

4<sup>th</sup>/5<sup>th</sup> Axis application of tooling machine



Six Axis Robot



Six Axis Robot

## FHA-E ORDERING INSTRUCTIONS



### ORDERING CODE EXAMPLE :

( For the type and ratio, please refer to technical specifications table.)

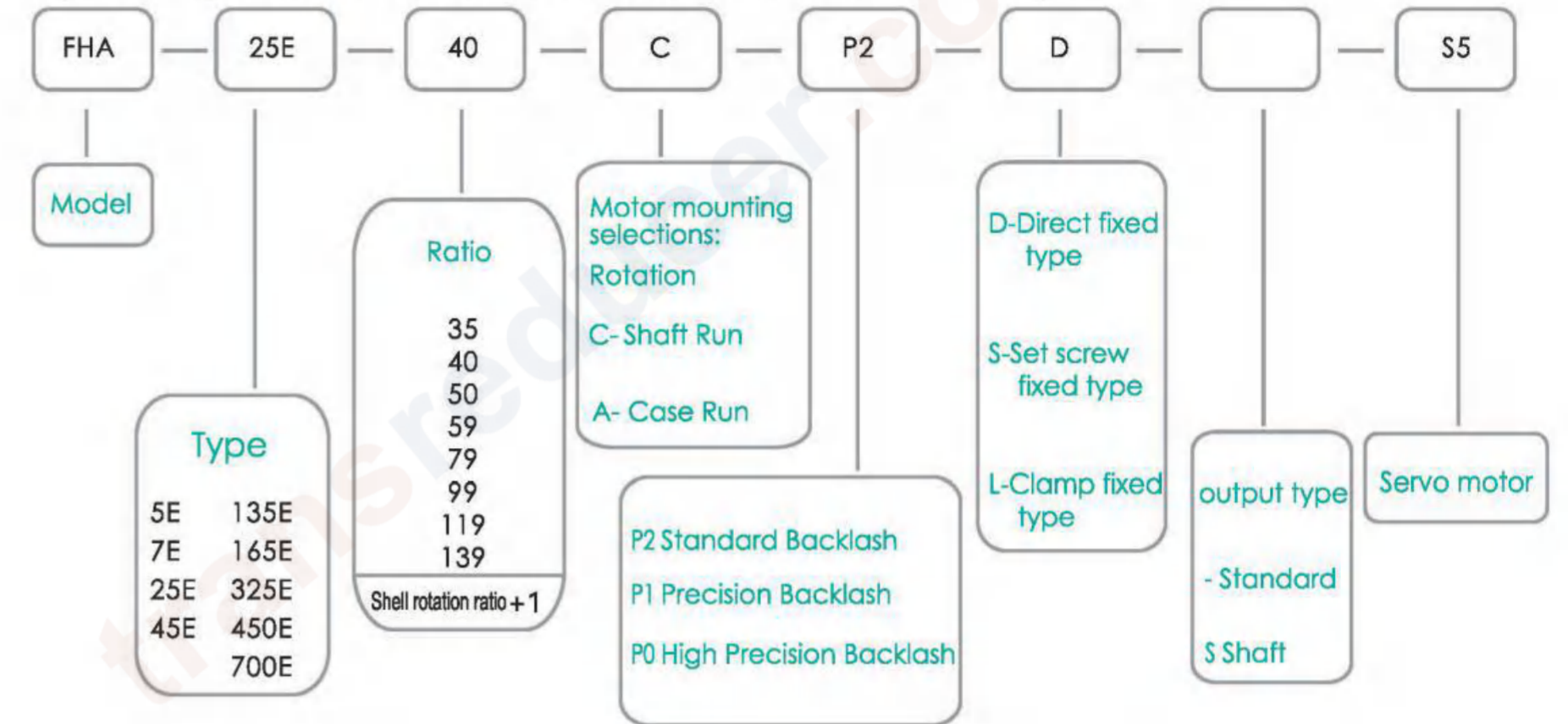

### Please provide the motor dimension below when ordering

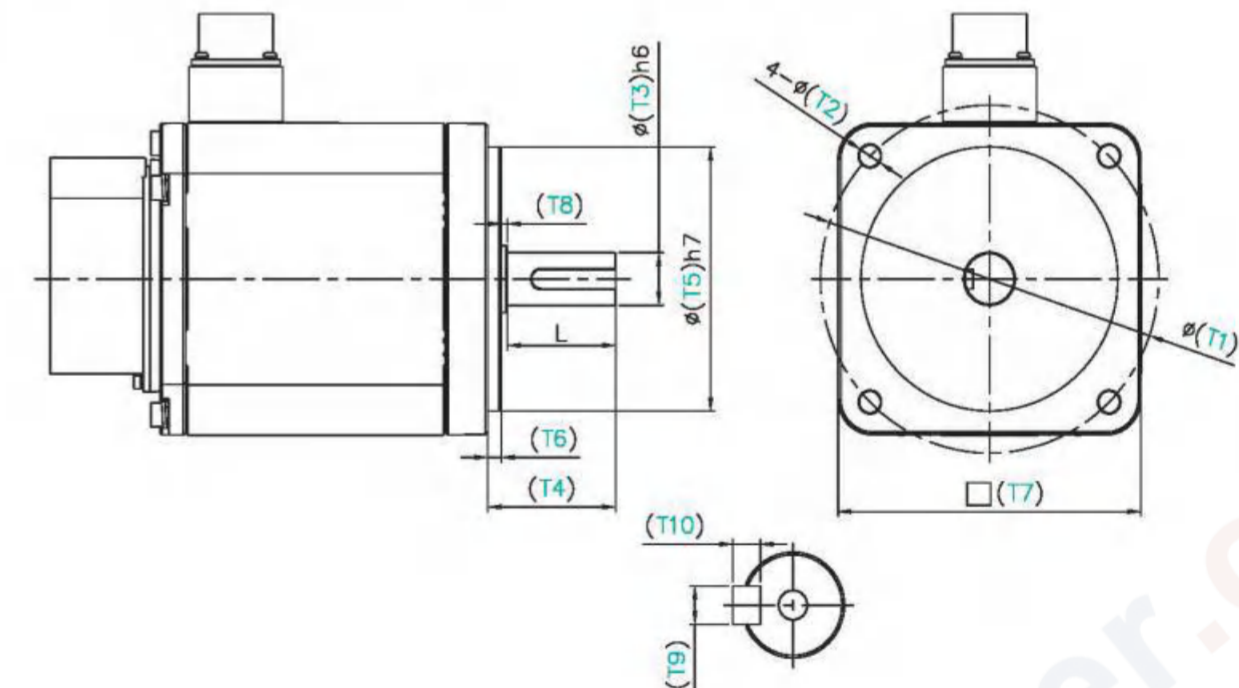

Motor Brand :					
Motor Model :					
T1	T2	T3	T4	T5	T6
P.C.D	Bolt Hole Diameter	Motor Shaft Diameter	Motor shaft length	Motor Pilot Diameter	Motor Pilot Height
T7	L	T8	T9	T10	
Motor Outline Dimension	Motor Shaht Lenght	Diameter required when using YASKAWA made motor	Key Width	Key Thickness	



# MOTOR MOUNTING SELECTIONS:

● D-直結式  
D-Direct fixed type

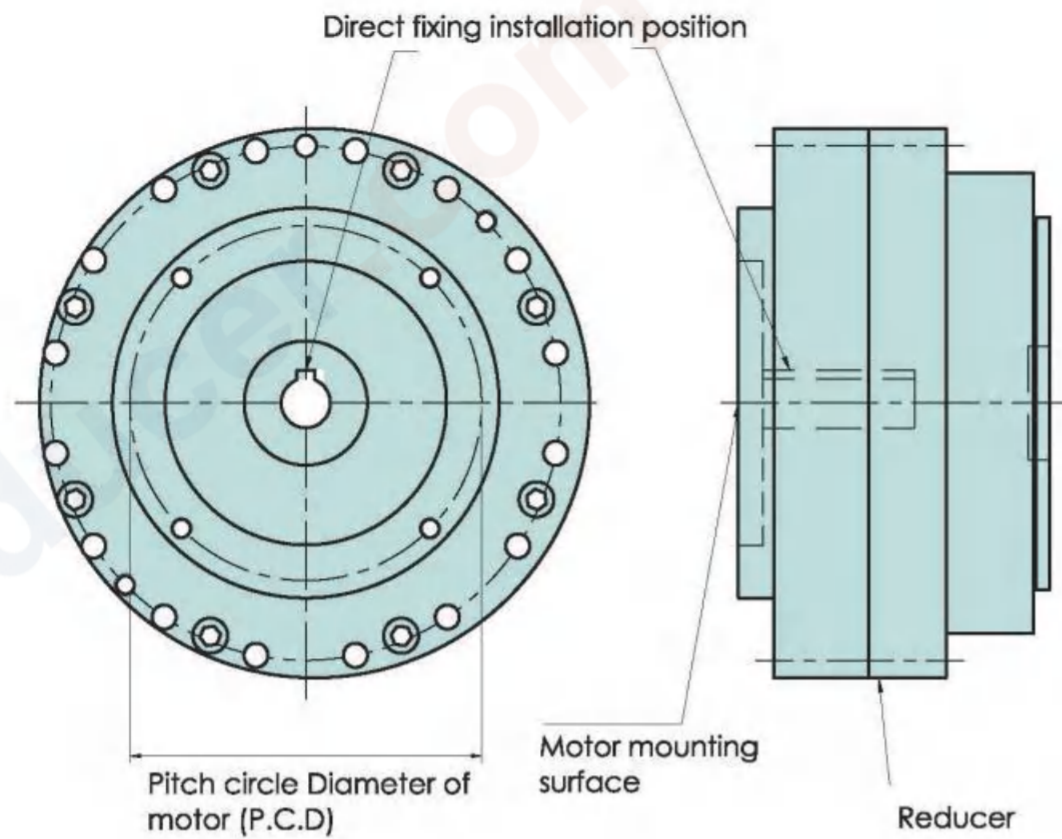

1. Place motor shaft key and reducer input shaft key way in a straight line, and insert motor shaft into reducer input shaft.
2. After connection of motor and reducer, tighten four screws into hex-socket cap screw holes.

● S-Set screw fixed type

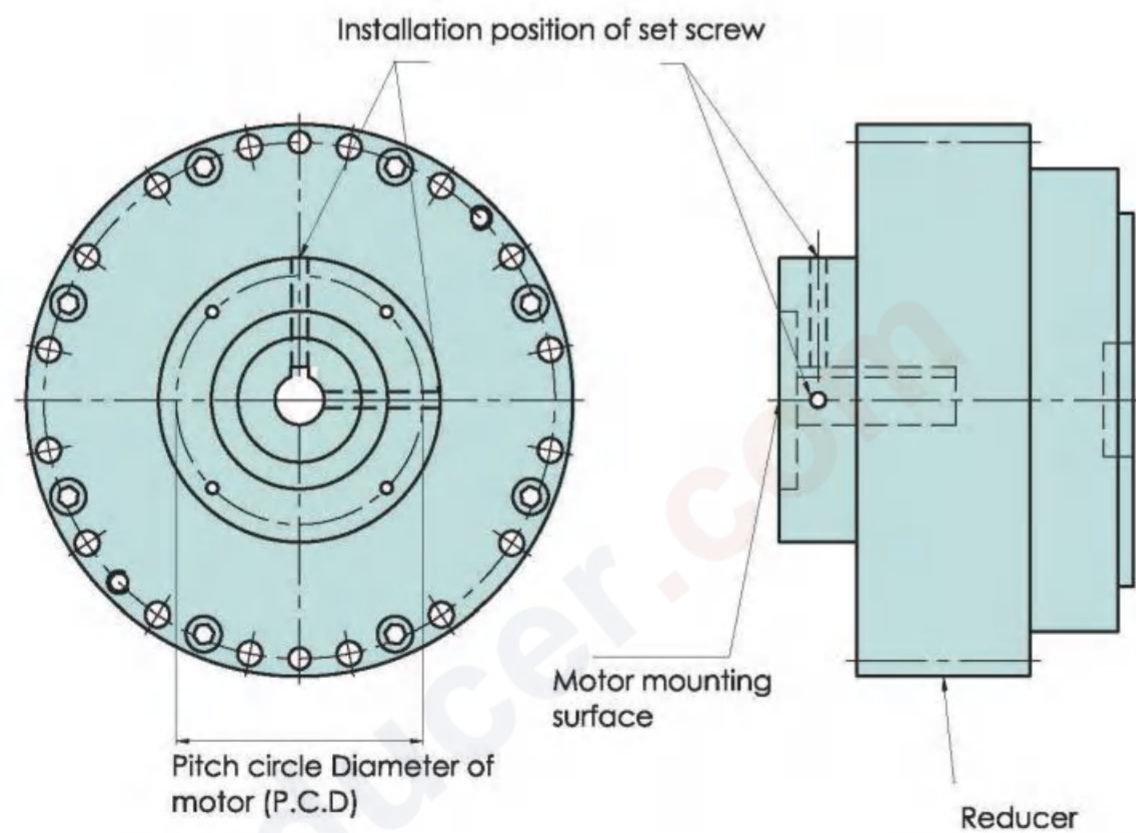

1. Place motor shaft key and reducer input shaft key way in a straight line, and insert motor shaft into reducer input shaft.
2. After connection of motor and reducer, tighten four screws into hex-socket cap screw holes.
3. Fix the set screw on reducer input shaft by T-type spanner.

● L-Clamp fixed type

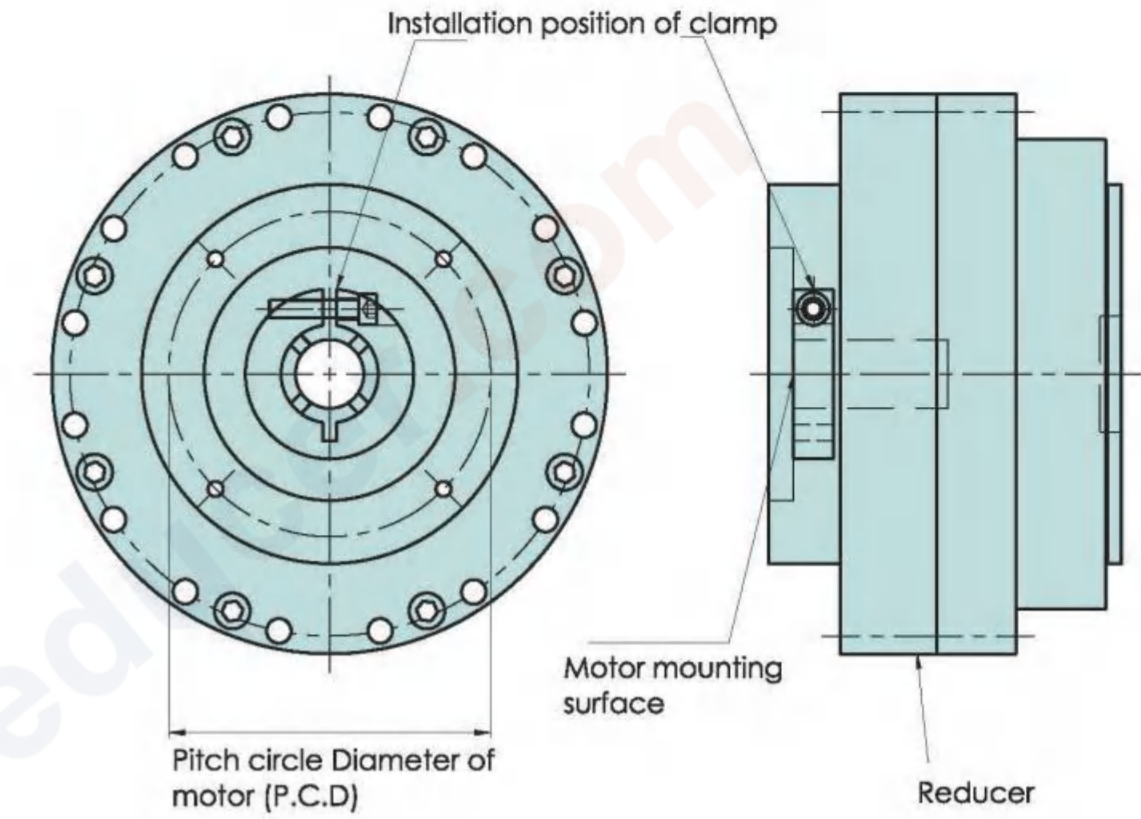

1. Place motor shaft key and reducer input shaft key way in a straight line, and insert motor shaft into reducer input shaft.
2. After connection of motor and reducer, tighten four screws into hex-socket cap screw holes.
3. Tighten the clamp of reducer input shaft by T-type spanner.

Output type :S-Shaft

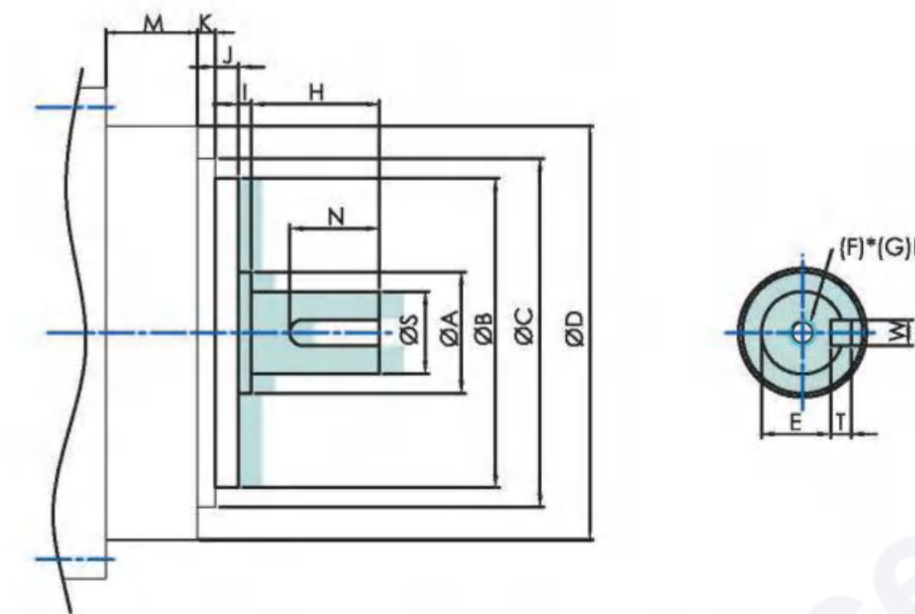

Model THA	M	K	J	I	H	N	A	B	C	D	S	W	T	E	F	G
5E	22	3	10	3	30	20	42	47	49	66	19	6	6	15.5	M6	12
7E	21	3	12	3	35	30	40	80	86	106	28	8	7	24	M8	15
25E	25	4.5	12	3	55	49	54	85	105	130	38	10	8	33	M8	15
45E	36	7	15	5	90	80	80	120	135	160	60	18	11	53	M10	18
135E	47.5	7.1	15	5	90	80	80	140	145	228	60	18	11	53	M10	18
165E	51	8	20	5	105	95	90	204	204	240	70	20	12	62.5	M12	24
325E	63.5	8	20	5	130	120	110	230	245	284	90	25	14	81	M16	30
450E	64	8	25	5	165	155	120	275	275	328	100	28	16	90	M20	40

# FHA-E TECHNICAL SPECIFICATION TABLE



FHA-E Technical Specification Table		FHA-E Technical Specification Table																		
Specification		FHA-5E		FHA-7E		FHA-25E		FHA-45E		FHA-135E		FHA-165E		FHA-325E		FHA-450E		FHA-700E		
Rotation		Shaft Run	Case Run	Shaft Run	Case Run	Shaft Run	Case Run	Shaft Run	Case Run	Shaft Run	Case Run	Shaft Run	Case Run	Shaft Run	Case Run	Shaft Run	Case Run	-		
Ratio		40	41	40	41	40	41			35	36	50	51	50	51	59	60	59	60	-
		50	51	50	51	50	51			40	41	60	61	60	61	79	80	79	80	-
		-	-	59	60	60	61			50	51	79	80	79	80	99	100	99	100	-
		-	-	-	-	-	-			59	60	99	100	99	100	119	120	119	120	-
		-	-	-	-	-	-			79	80	-	-	-	-	-	-	139	140	-
Rated Output Torque	Nm kgf-m	60 (6.1)	83 (8.46)	245 (25)	245 (25)	460 (46.8)	460 (46.8)	1400 (136)	1400 (136)	1615 (165)	1615 (165)	3595 (366)	3595 (366)	5100 (520)	5100 (520)	-	-	-	-	
Acceleration & Braking Torque	Nm kgf-m	97.5 (9.9)	136 (14)	515 (52)	515 (52)	1158 (118)	1158 (118)	2083 (212)	2083 (212)	4043 (412)	4043 (412)	7963 (812)	7963 (812)	11025 (1125)	11025 (1125)	-	-	-	-	
Instantaneous Max. Allowable Torque	Nm kgf-m	245 (25)	415 (42)	1000 (102)	1000 (102)	2300 (234.4)	2300 (234.4)	4155 (423.5)	4155 (423.5)	8075 (823)	8075 (823)	17975 (1830)	17975 (1830)	25500 (2600)	25500 (2600)	-	-	-	-	
Rated Input Speed	Nr (rpm)	2000	2000	2000	2000	2000	2000	2000	2000	1500	1500	1500	1500	1500	1500	-	-	-	-	
Rated Lifetime	Hr	6000	6000	6000	6000	6000	6000	6000	6000	6000	6000	6000	6000	6000	6000	-	-	-	-	
Allowable Max. Input Speed	Nmax (rpm)	3000	3000	3000	3000	3000	3000	3000	2500	2500	2500	2000	2000	2000	2000	-	-	-	-	
Tilting Stiffness	Nm/arc.min kgf-m/arc.min	82 (8.3)	117 (12)	372 (38)	372 (38)	931 (95)	931 (95)	1176 (120)	1176 (120)	2940 (300)	2940 (300)	4900 (500)	4900 (500)	7448 (760)	7448 (760)	-	-	-	-	
Torsional Stiffness	Nm/arc.min kgf-m/arc.min	18 (1.83)	20 (2)	49 (5)	49 (5)	108 (11)	108 (11)	196 (20)	196 (20)	392 (40)	392 (40)	980 (100)	980 (100)	1176 (120)	1176 (120)	-	-	-	-	
Max.Lost Motion	(arc.min)	<3.0	<3.0	<2.0	<2.0	<2.0	<2.0	<1.5	<1.5	<1.5	<1.5	<1.5	<1.5	<1.5	<1.5	-	-	-	-	
Angular Transmission Error	ATE (arc.sec)	40	80	40	40	40	40	40	40	40	40	40	40	40	40	-	-	-	-	
Backlash	Standard Backlash	<5.0	<5.0	<5.0	<5.0	<5.0	<5.0	<4.0	<4.0	<4.0	<4.0	<4.0	<4.0	<4.0	<4.0	-	-	-	-	
	Precision Backlash	<3.0	<3.0	<3.0	<3.0	<3.0	<3.0	<2.0	<2.0	<2.0	<2.0	<2.0	<2.0	<2.0	<2.0	-	-	-	-	
	High Precision Backlash	-	-	-	-	<1.0	<1.0	<1.0	<1.0	<1.0	<1.0	<1.0	<1.0	<1.0	<1.0	-	-	-	-	
Maximum Tilting Moment	Nm kgf-m	282 (28.8)	392 (40)	1764 (180)	1764 (180)	3332 (340)	3332 (340)	4312 (440)	4312 (440)	7840 (800)	7840 (800)	14112 (1440)	14112 (1440)	17640 (1800)	17640 (1800)	-	-	-	-	
Rated Radial Force	Nm	118	196	882	882	1666	1666	2156	2156	3920	3920	7056	7056	8820	8820	-	-	-	-	
Max. Axial Force	N	885	1470	3920	3920	5194	5194	7840	7840	14700	14700	19600	19600	24500	24500	-	-	-	-	
(I=GD <sup>2</sup> /4)	Input Inertia Kg-m <sup>2</sup>	1.65×10 <sup>-6</sup>	2.60×10 <sup>-6</sup>	1.08×10 <sup>-5</sup>	1.08×10 <sup>-5</sup>	4.50×10 <sup>-5</sup>	4.50×10 <sup>-5</sup>	5.65×10 <sup>-5</sup>	5.65×10 <sup>-5</sup>	1.9×10 <sup>-4</sup>	1.9×10 <sup>-4</sup>	6×10 <sup>-4</sup>	6×10 <sup>-4</sup>	9×10 <sup>-4</sup>	9×10 <sup>-4</sup>	-	-	-	-	
		1.46×10 <sup>-6</sup>	1.85×10 <sup>-6</sup>	0.65×10 <sup>-5</sup>	0.65×10 <sup>-5</sup>	3.75×10 <sup>-5</sup>	3.75×10 <sup>-5</sup>	4.40×10 <sup>-5</sup>	4.40×10 <sup>-5</sup>	1.8×10 <sup>-4</sup>	1.8×10 <sup>-4</sup>	5.4×10 <sup>-4</sup>	5.4×10 <sup>-4</sup>	7.3×10 <sup>-4</sup>	7.3×10 <sup>-4</sup>	-	-	-	-	
		-	1.66×10 <sup>-6</sup>	0.45×10 <sup>-5</sup>	0.45×10 <sup>-5</sup>	2.4×10 <sup>-5</sup>	2.4×10 <sup>-5</sup>	3.53×10 <sup>-5</sup>	3.53×10 <sup>-5</sup>	1.78×10 <sup>-4</sup>	1.78×10 <sup>-4</sup>	4×10 <sup>-4</sup>	4×10 <sup>-4</sup>	6×10 <sup>-4</sup>	6×10 <sup>-4</sup>	-	-	-	-	
		-	-	-	-	1.75×10 <sup>-5</sup>	1.75×10 <sup>-5</sup>	2.63×10 <sup>-5</sup>	2.63×10 <sup>-5</sup>	1.51×10 <sup>-4</sup>	1.51×10 <sup>-4</sup>	2.8×10 <sup>-4</sup>	2.8×10 <sup>-4</sup>	4.8×10 <sup>-4</sup>	4.8×10 <sup>-4</sup>	-	-	-	-	
Weight	KG	1.5	4.5	8.5	8.5	12	12	32.5	32.5	37	37	65	65	81	81	-	-	-	-	

Please contact us for other ratio selections. Please be noted that the noise will be increased when the input speed (RPM:revolution per minute)of motor is higher than rated input speed; the operating temperature and motor service temperature should be under 70°C.

# DRAWING&DIMENSION

## FHA-5E-□-C-□-D

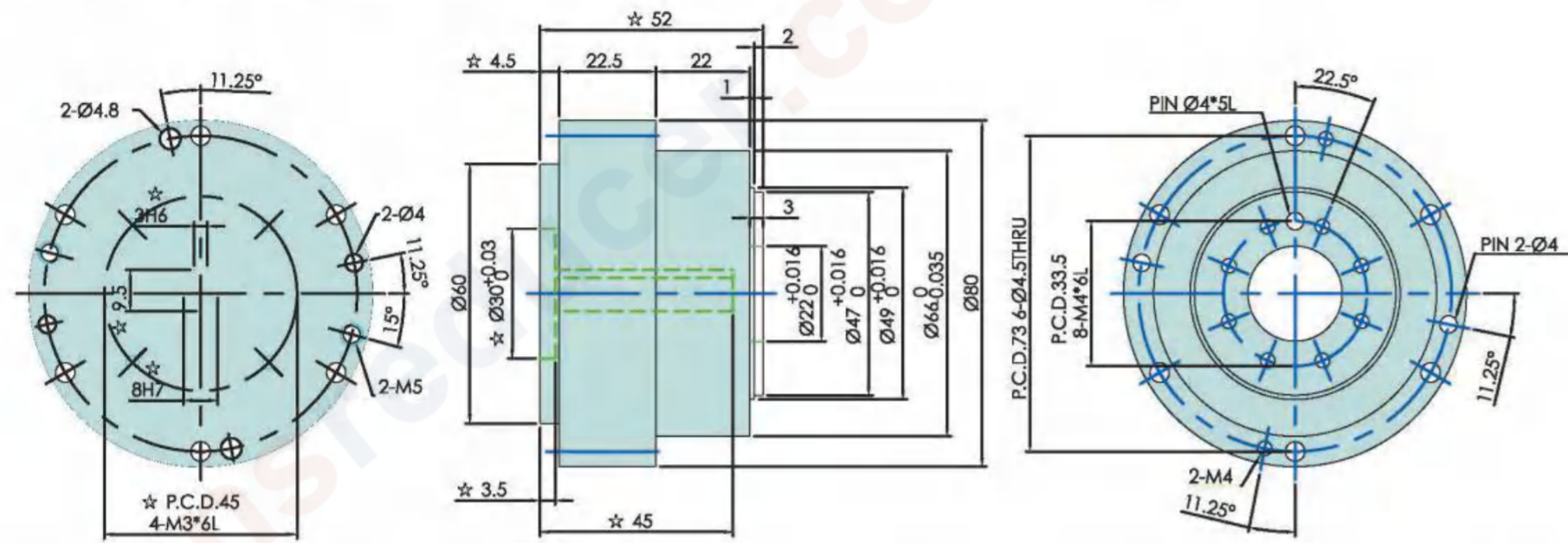

1. "☆"The dimensions modify with motor specification.
2. Output shaft diameter  $\Phi 8 \sim \Phi 11$  mm.
3. This drawing is model of shaft rotation, for case run drawing, please contact us.

## FHA-7E-□-C-□-D

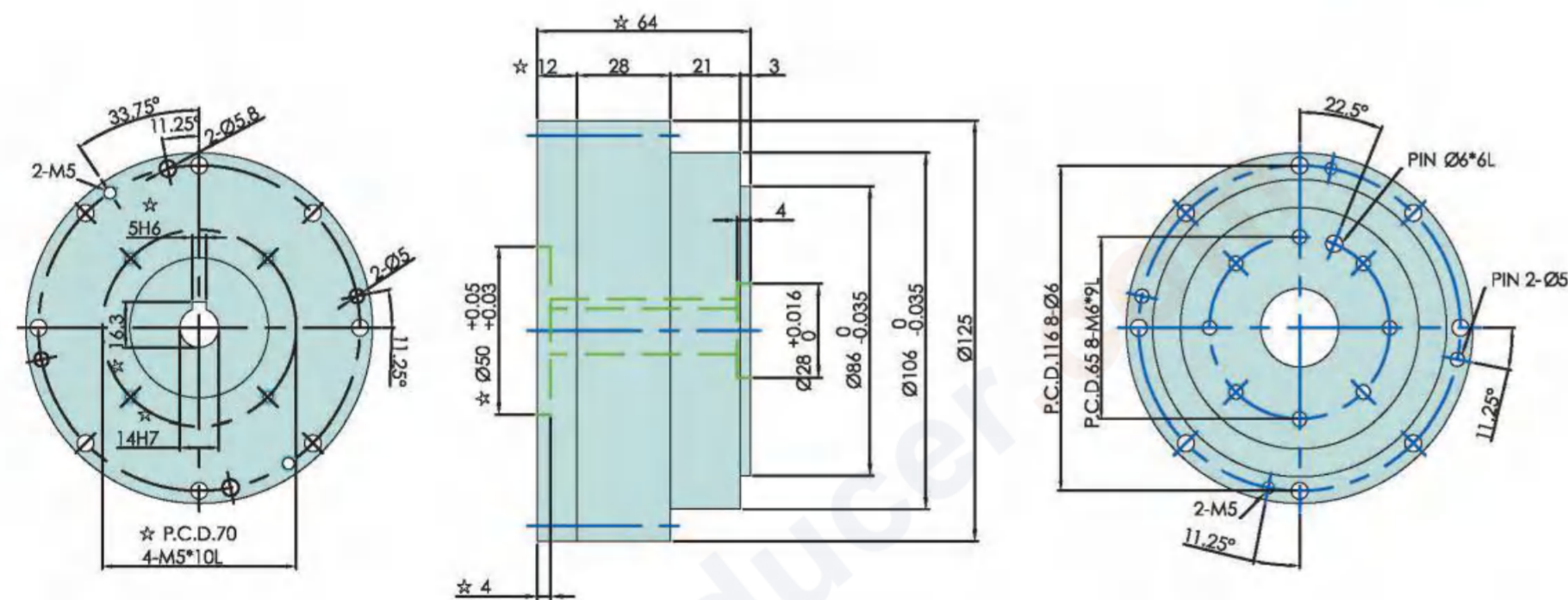

1. "☆"The dimensions modify with motor specification.
2. Output shaft diameter  $\Phi 11 \sim \Phi 19$  mm.
3. This drawing is model of shaft rotation, for case run drawing, please contact us.

## FHA-25E-□-C-□-D

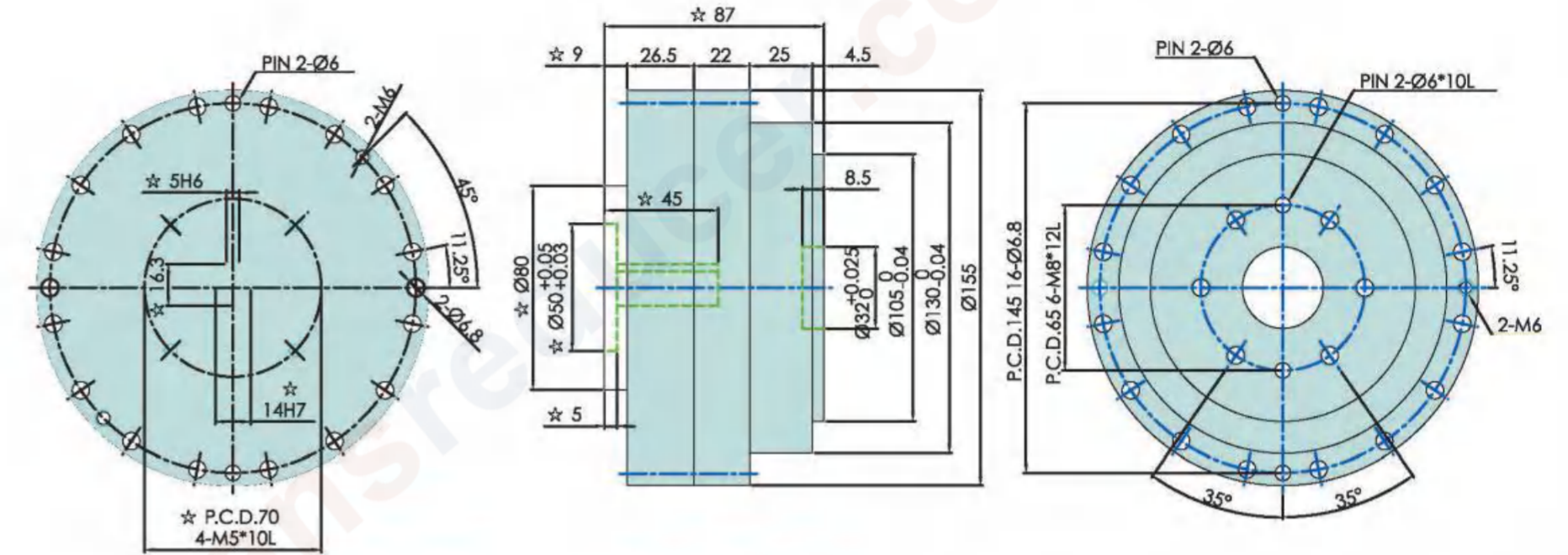

1. "☆"The dimensions modify with motor specification.
2. Output shaft diameter  $\Phi 11 \sim \Phi 24$  mm.
3. This drawing is model of shaft rotation, for case run drawing, please contact us.

## FHA-45E-□-C-□-D

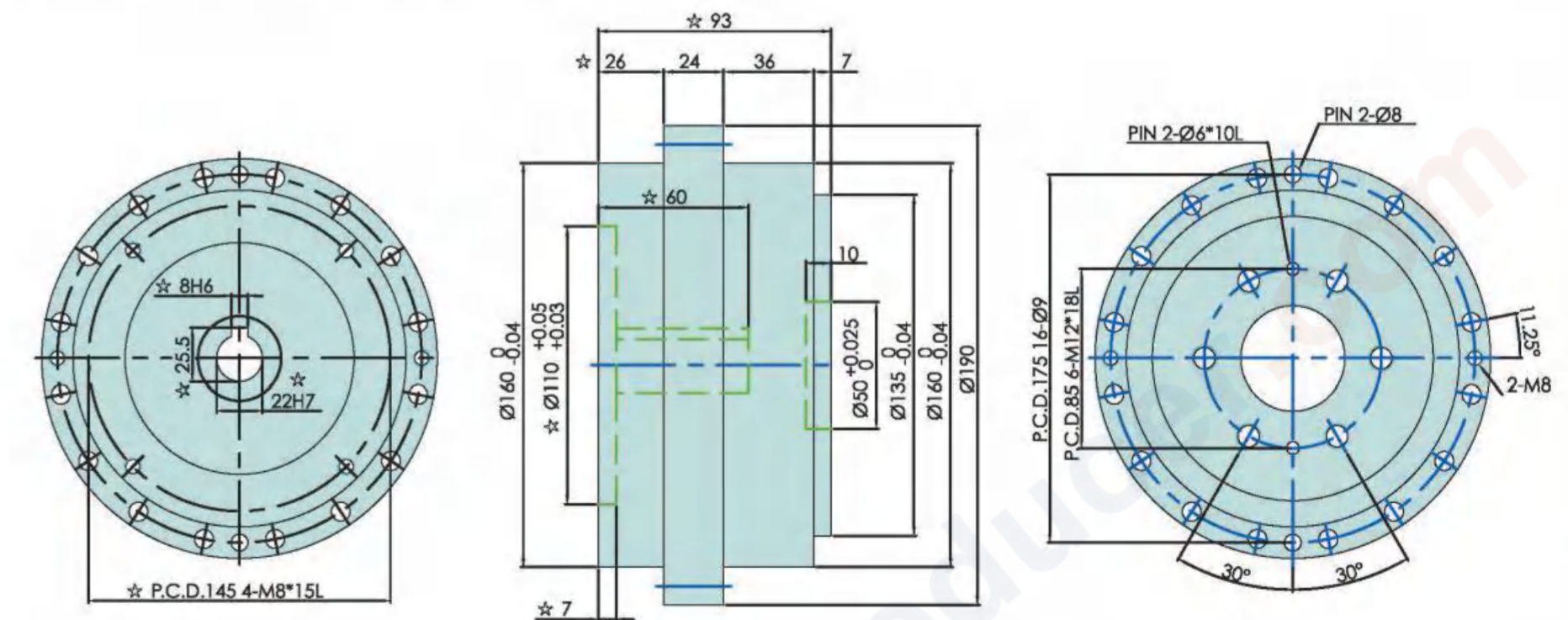

1. "☆"The dimensions modify with motor specification.
2. Output shaft diameter  $\Phi 14 \sim \Phi 28$  mm.
3. This drawing is model of shaft rotation, for case run drawing, please contact us.

# DRAWING&DIMENSION

## FHA-135E-□-C-□-D

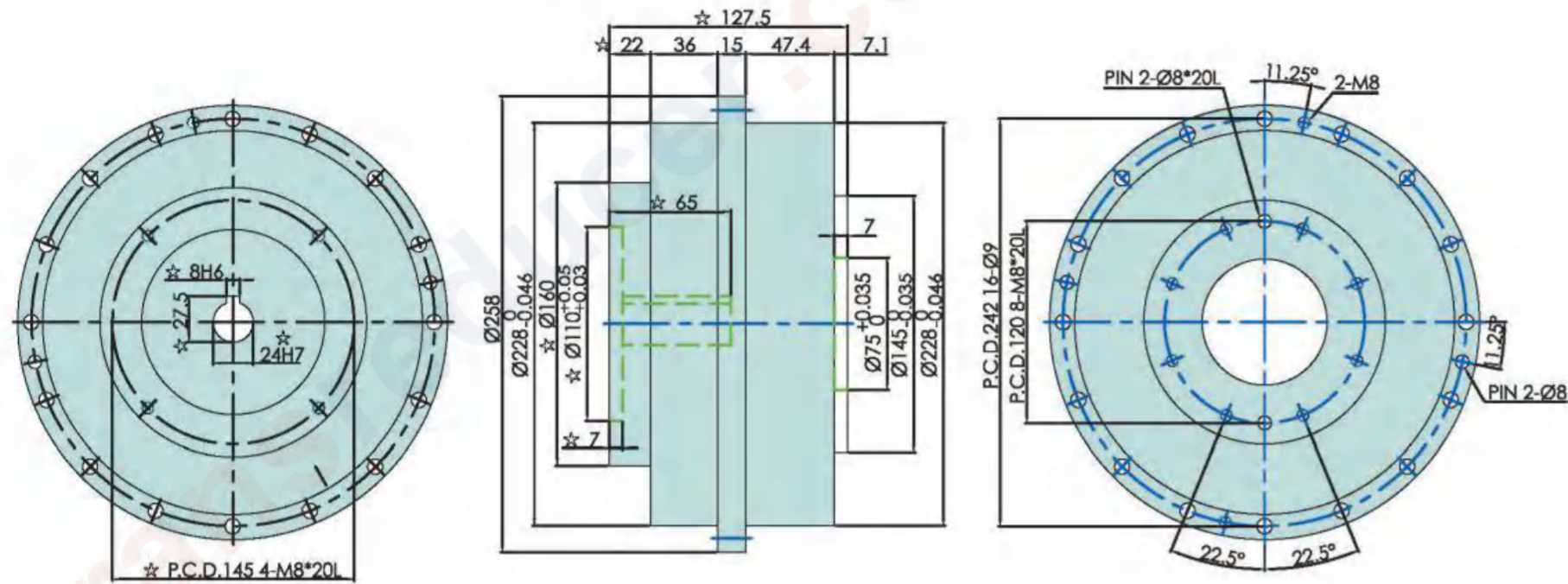

1. "☆"The dimensions modify with motor specification.
2. Output shaft diameter  $\Phi 19 \sim \Phi 35$  mm.
3. This drawing is model of shaft rotation, for case run drawing, please contact us.

## FHA-165E-□-C-□-D

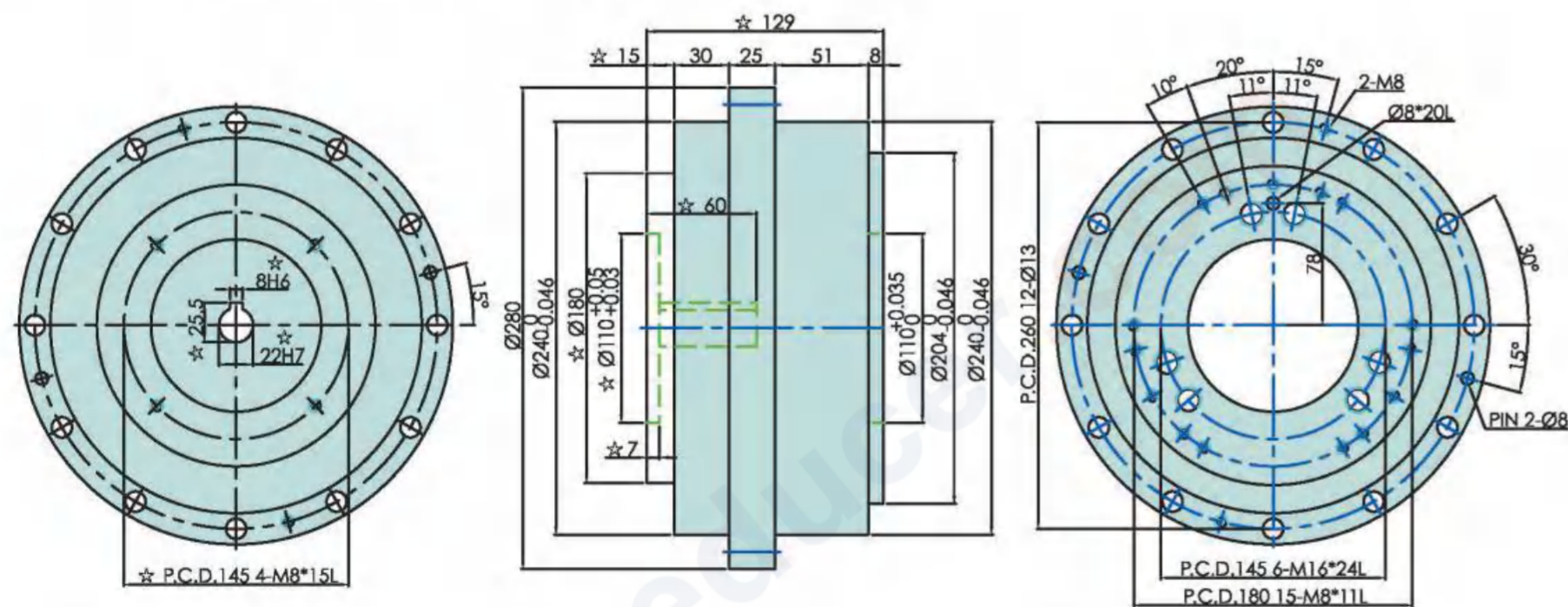

1. "☆"The dimensions modify with motor specification.
2. Output shaft diameter  $\Phi 22 \sim \Phi 42$  mm.
3. This drawing is model of shaft rotation, for case run drawing, please contact us.

## FHA-325E-□-C-□-D

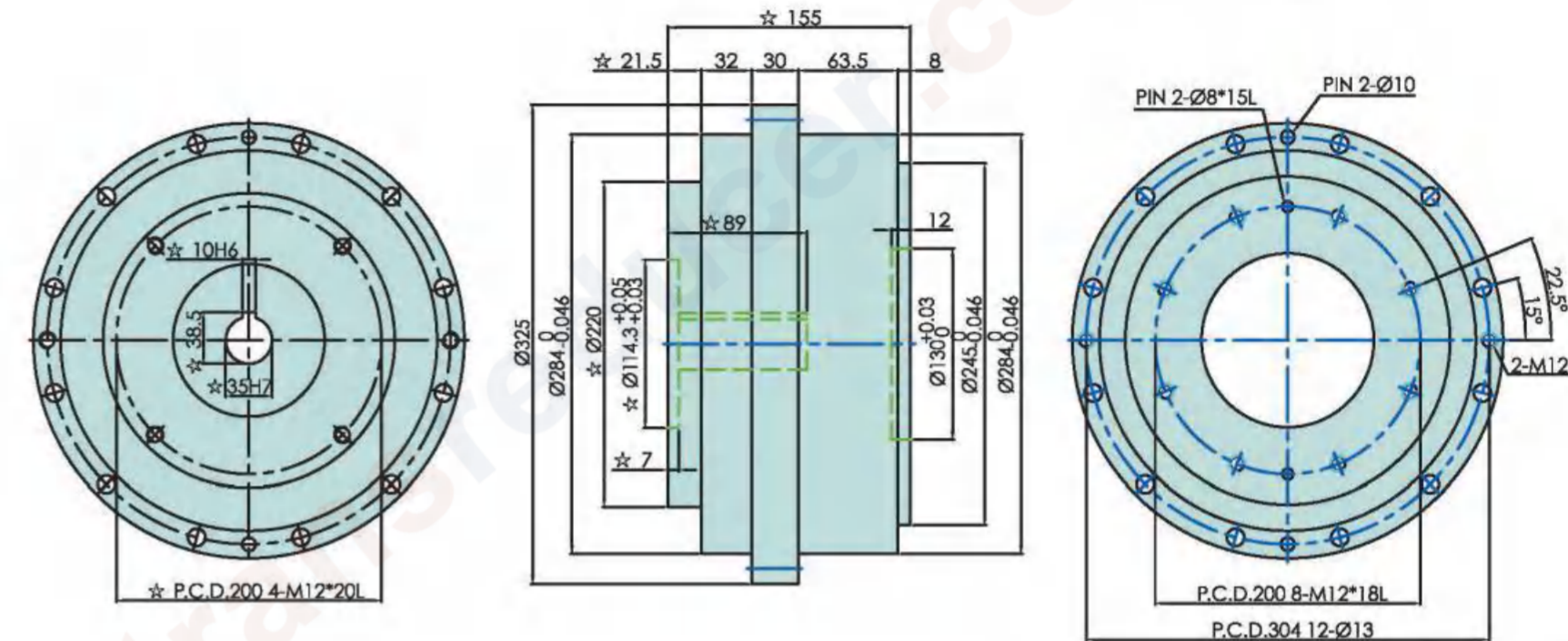

1. "☆"The dimensions modify with motor specification.
2. Output shaft diameter  $\Phi 24 \sim \Phi 42$  mm.
3. This drawing is model of shaft rotation, for case run drawing, please contact us.

## FHA-450E-□-C-□-D

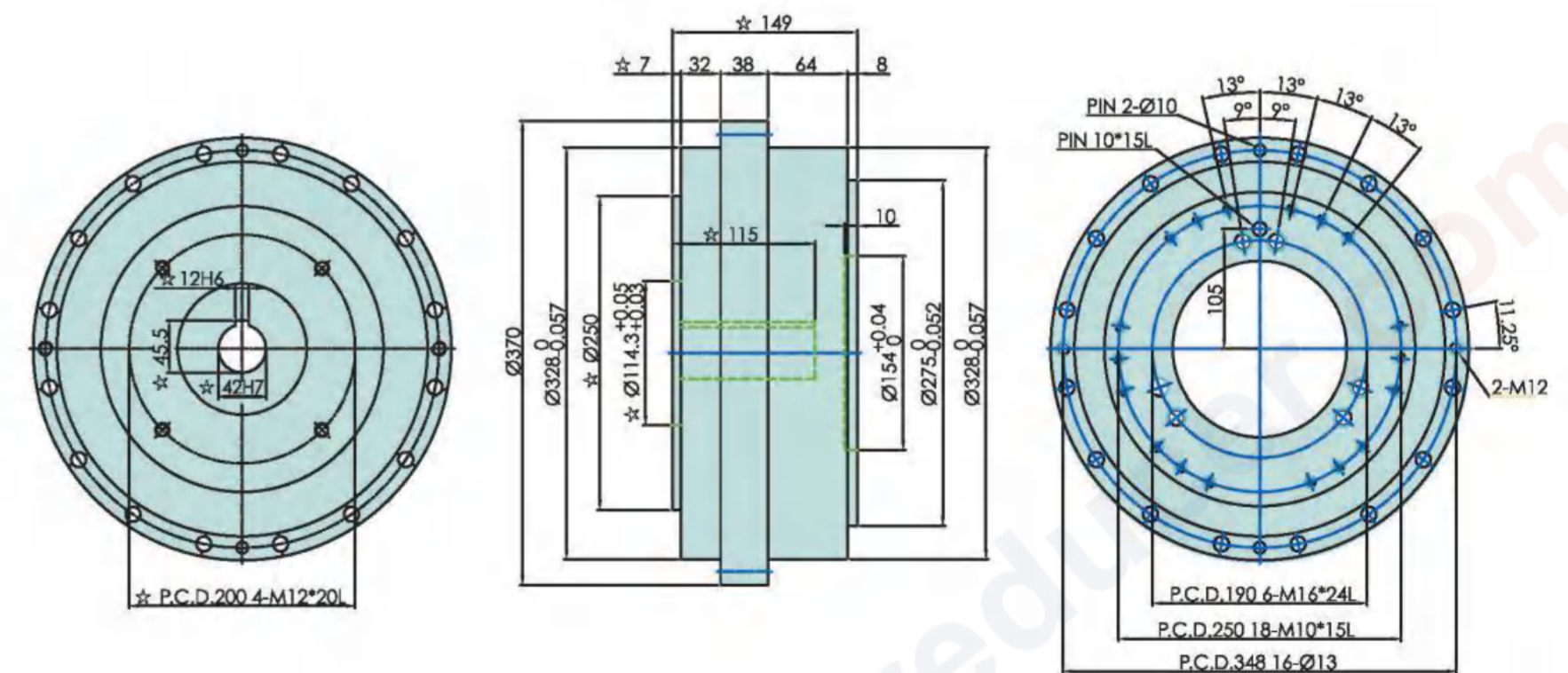

1. "☆"The dimensions modify with motor specification.
2. Output shaft diameter  $\Phi 35 \sim \Phi 60$  mm.
3. This drawing is model of shaft rotation, for case run drawing, please contact us.

# FHD-C SERIES

HOLLOW BODY DESIGN, DIRECT OUTPUT  
DESIGNED FOR BASE OF ROBOT



## Overview

- Type : FHD-10C~FHD-500C
- Backlash:  $\leq 1-5$  Arc.min
- Ratio : 1/64.38 ~ 1/219
- Capacity: 0.2KW ~ 15KW
- Rotation : Shaft Run
- Rated output torque: 98NM ~ 4900NM

## FHD-C ORDERING INSTRUCTIONS



- ORDERING CODE EXAMPLE :

( For the type and ratio, please refer to technical specifications table.)

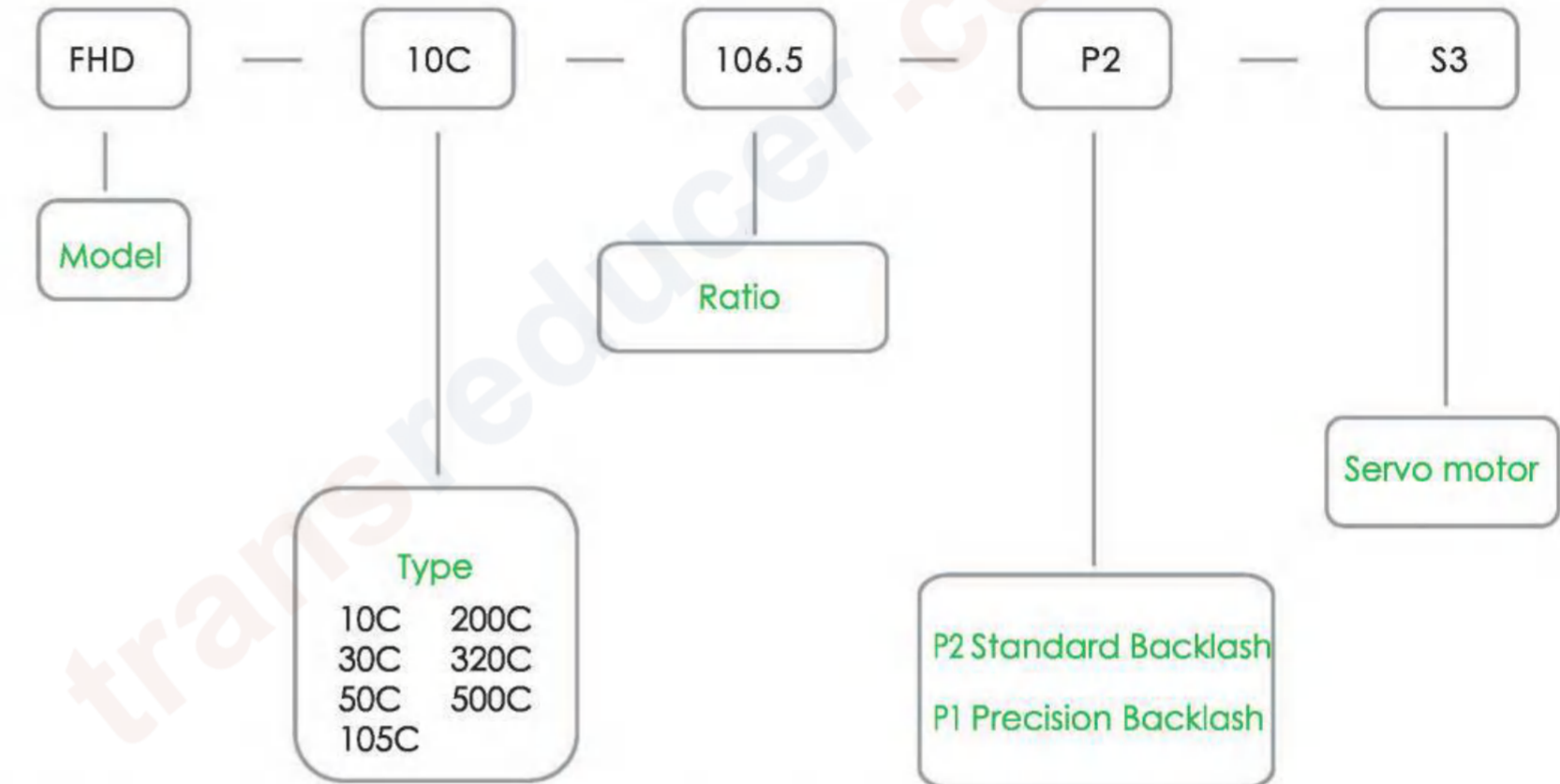

- Please provide the motor dimension below when ordering

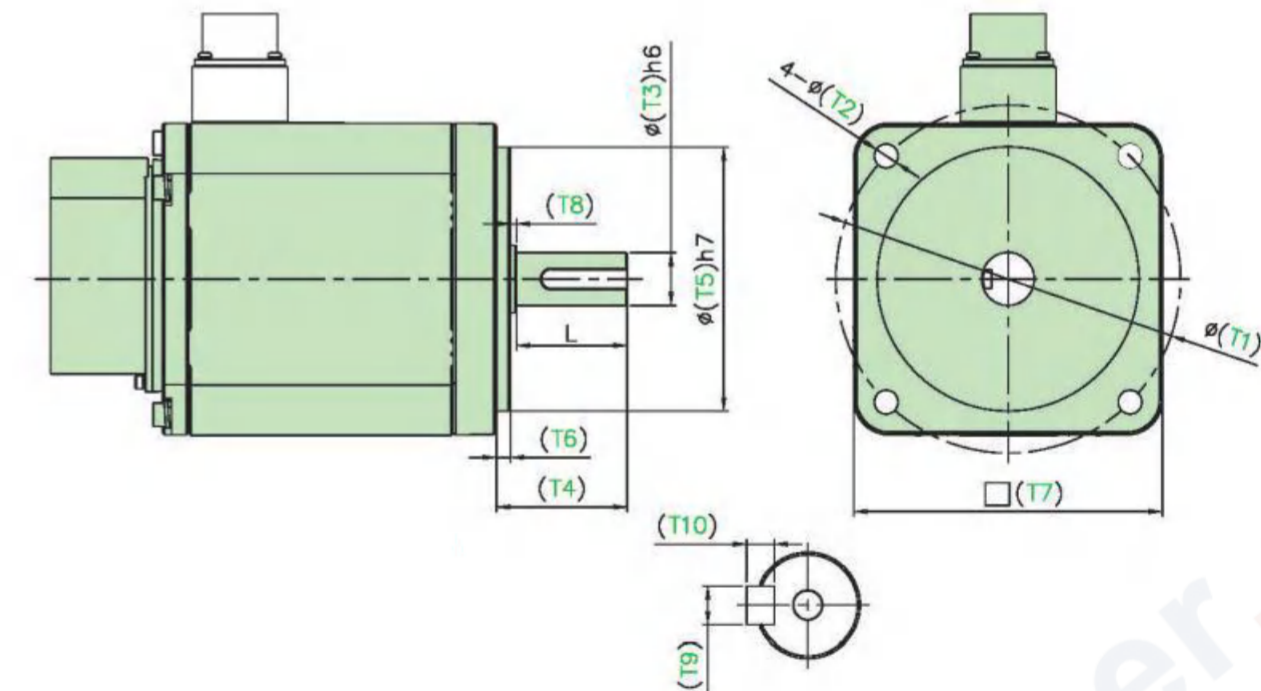

Motor Brand :					
Motor Model :					
T1	T2	T3	T4	T5	T6
P.C.D	Bolt Hole Diameter	Motor Shaft Diameter	Motor shaft length	Motor Pilot Diameter	Motor Pilot Height
T7	L	T8	T9	T10	
Motor Outline Dimension	Motor Shaft Length	Diameter required when using YASKAWA made motor	Key Width	Key Thickness	

# FHD-C TECHNICAL SPECIFICATION TABLE



Specification		FHD-C Technical Specification Table				FHD-C Technical Specification Table			
		FHD-10C	FHD-30C	FHD-50C	FHD-105C	FHD-200C	FHD-320C	FHD-500C	FHD-700C
Rotation		Shaft Run	Shaft Run	Shaft Run	Shaft Run	Shaft Run	Shaft Run	Shaft Run	-
Ratio		106.5	64.38	78.4	97.6777	71.9924	94.5	111	-
		154	84.18	102.4	110.5677	92.2932	109.5	147	-
		-	103.98	126.4	136.3478	105.827	123	183	-
		-	-	-	187.9079	137.9699	153	219	-
		-	-	-	-	-	-	-	-
Rated Output Torque	Nm	98	295	490	1030	1960	3136	4900	-
	kgf-m	(10)	(30)	(50)	(105)	(200)	(325)	(500)	-
Acceleration & Braking Torque	Nm	245	737	1225	2575	4900	7840	12250	-
	kgf-m	(25)	(75)	(125)	(262)	(500)	(800)	(1250)	-
Instantaneous Max. Allowable Torque	Nm	490	1475	2450	5150	9800	15680	24500	-
	kgf-m	(50)	(150)	(250)	(525)	(1000)	(1600)	(2500)	-
Rated Input Speed	Nr (rpm)	2000	2000	1500	1500	1500	1500	1500	-
Rated Output Speed	Nr (rpm)	15	15	15	15	15	15	15	-
Rated Lifetime	Hr	6000	6000	6000	6000	6000	6000	6000	-
Maximum Allowable Output Speed (Intermittent)	Nmax (rpm)	28	47	38	26	28	21	18	-
		19	36	29	23	22	18	14	-
		-	29	24	18	19	16	11	-
		-	-	-	13	14	13	9	-
Allowable Output Speed (Continuous)	Min (rpm)	19	31	26	15	21	16	14	-
		13	24	20	14	16	14	10	-
		-	19	16	11	14	12	8	-
		-	-	-	8	11	10	7	-
Tilting Stiffness	Nm/arc.min kgf-m/arc.min	421	1068	1960	2813	9800	12740	24500	-
		(43)	(109)	(200)	(287)	(1000)	(1300)	(2500)	-
Torsional Stiffness	Nm/arc.min kgf-m/arc.min	47	147	255	510	980	1960	3430	-
		(4.8)	(15)	(26)	(52)	(100)	(200)	(350)	-
Max.Lost Motion	(arc.min)	<2.0	<2.0	<1.0	<1.0	<1.0	<1.0	<1.0	-
Angular Transmission Error	ATE (arc.sec)	50	50	50	50	50	50	50	-
Backlash	Standard Backlash	<5.0	<4.0	<3.0	<3.0	<3.0	<3.0	<3.0	-
	Precision Backlash	<3.0	<2.0	<1.0	<1.0	<1.0	<1.0	<1.0	-
Maximum Tilting Moment	Nm kgf-m	1372	1960	3528	4900	17640	39200	78400	-
		(140)	(200)	(360)	(500)	(1800)	(4000)	(8000)	-
Rated Radial Force	Nm	686	980	1764	2450	8820	20580	34300	-
Max.Axial Force	N	5880	8820	11760	13720	19600	29400	39200	-
Start Efficiency	%	65	70	70	80	80	80	80	-
Weight	KG	10.7	20	34	46	100	176	-	-

Please contact us for other ratio selections. Please be noted that the noise will be increased when the input speed (RPM:revolution per minute) of motor is higher than rated input speed; the operating temperature and motor service temperature should be under 70°C.

# FHD-C DRAWING & DIMENSION

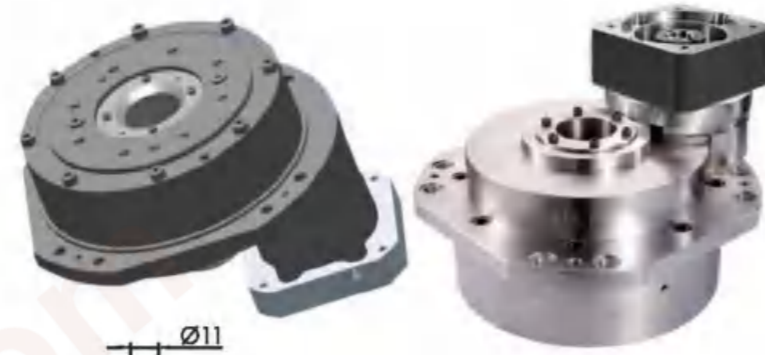

## FHD-10C

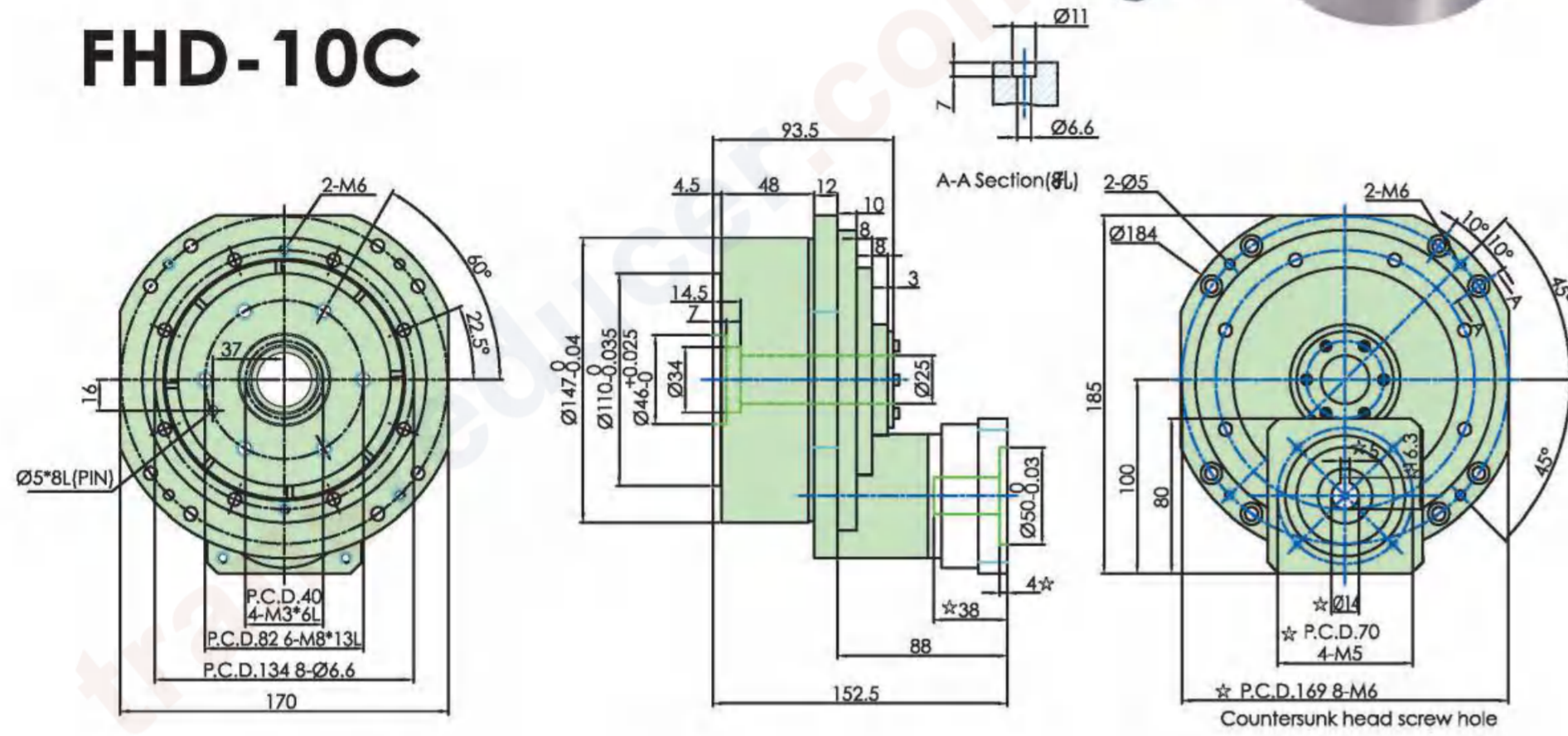

1. "☆"The dimensions modify with motor specification.
2. The drawing is for output flange rotation (shaft run)

## FHD-50C

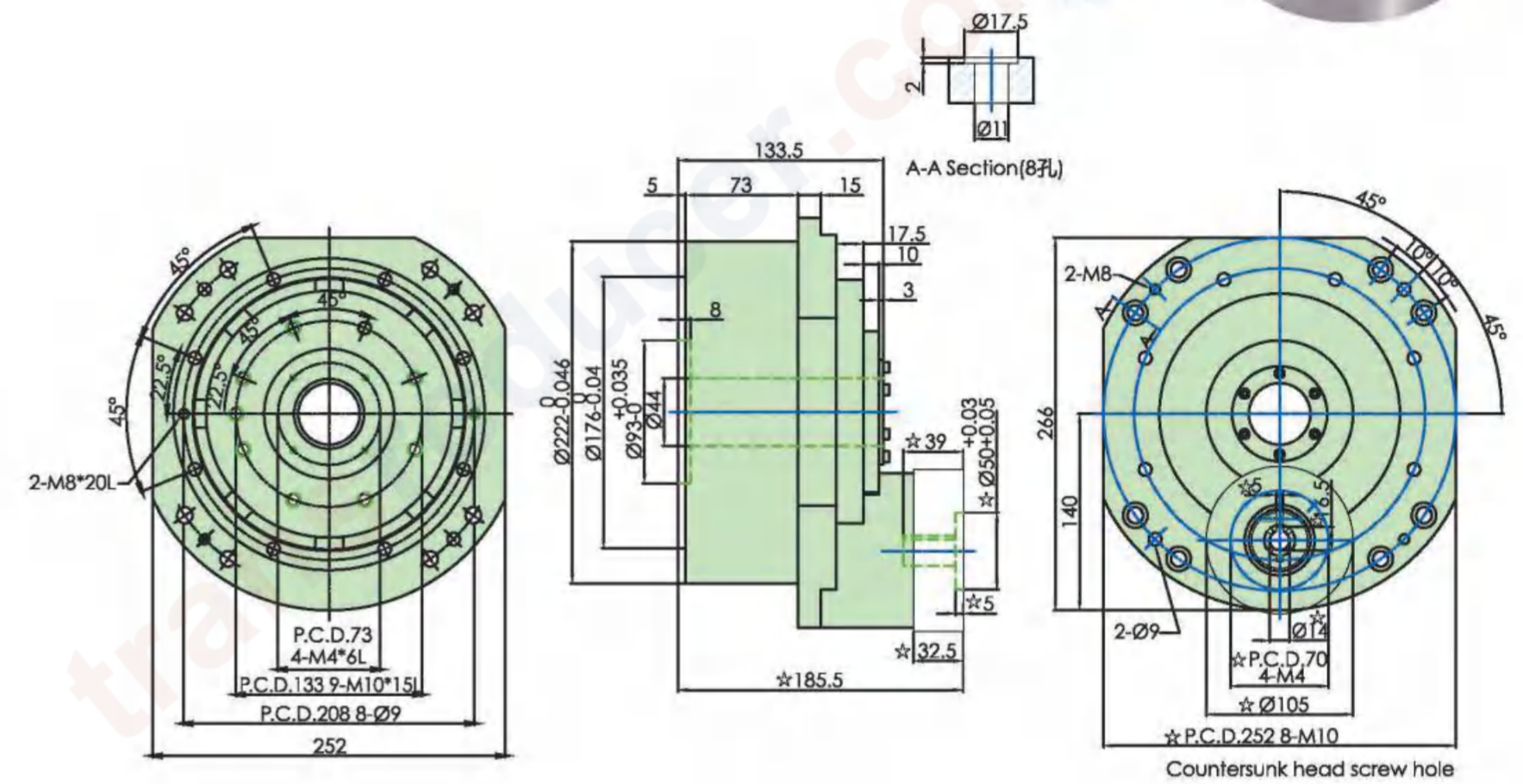

1. "☆"The dimensions modify with motor specification.
2. The drawing is for output flange rotation (shaft run)

## FHD-30C

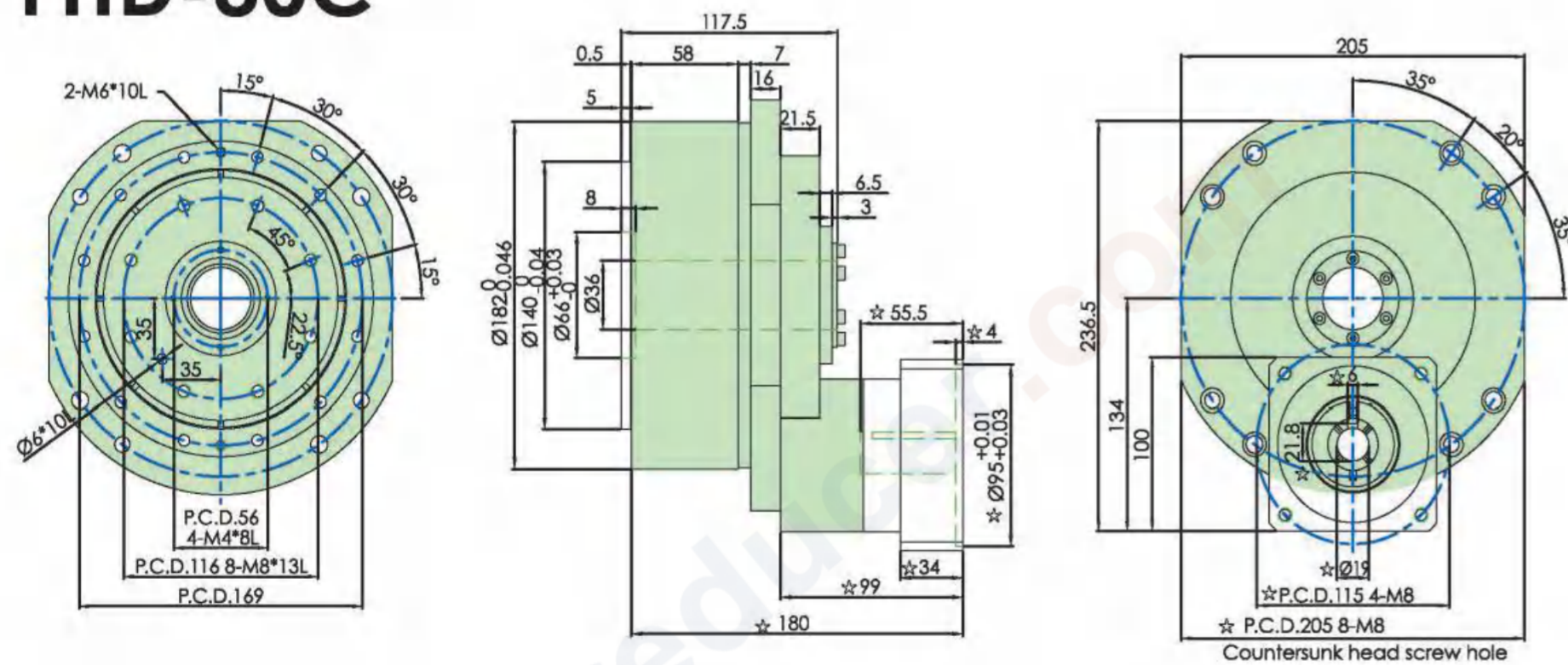

1. "☆"The dimensions modify with motor specification.
2. The drawing is for output flange rotation (shaft run)

## FHD-105C

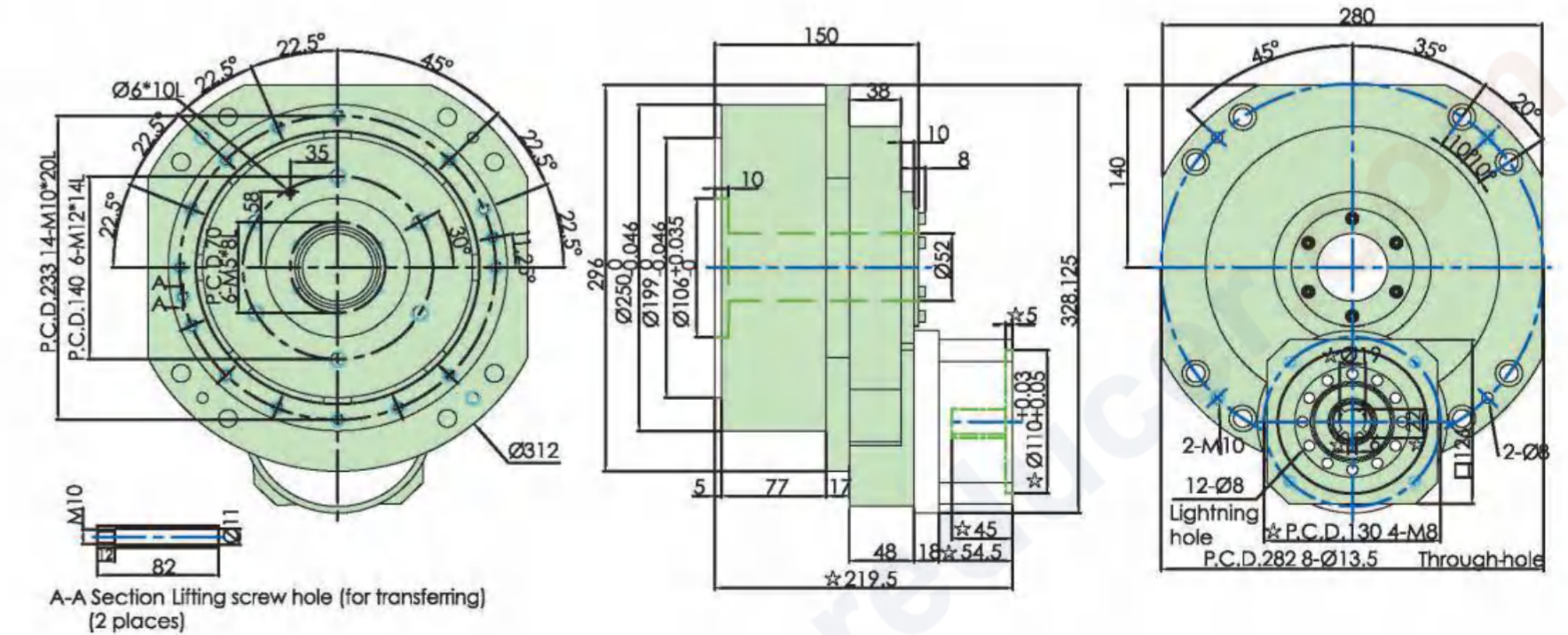

1. "☆"The dimensions modify with motor specification.
2. The drawing is for output flange rotation (shaft run)

